

PAGE 1/3	ISSUE 1328C	SERIES ECO 7/16	PART NUMBER R185A031200
----------	-------------	-----------------	-------------------------

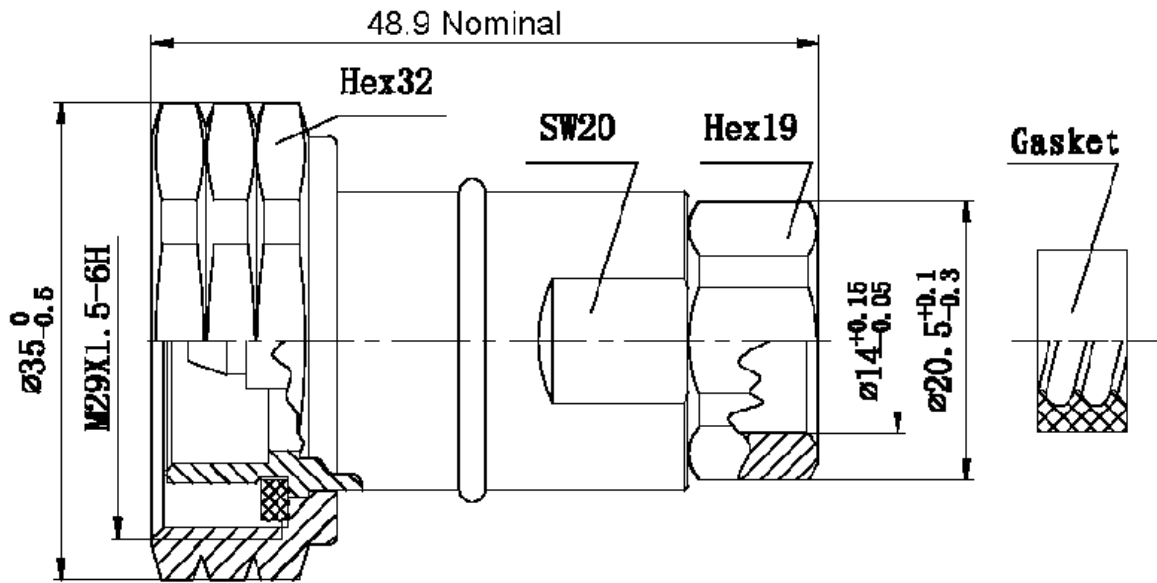

All dimensions are in mm.

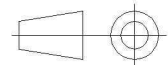

COMPONENTS	MATERIALS	PLATING (µm)
Body	<b>BRASS</b>	<b>BBR</b>
Center contact	<b>BRONZE</b>	<b>SILVER</b>
Outer contact		
Insulator	<b>PTFE</b>	
Gasket	<b>SILICONE RUBBER</b>	
Others parts	<b>BRASS</b>	<b>BBR</b>
-	-	-
-	-	-

PAGE <b>2/3</b>	ISSUE <b>1328C</b>	SERIES <b>ECO 7/16</b>	PART NUMBER <b>R185A031200</b>
-----------------	--------------------	------------------------	--------------------------------

### PACKAGING

Standard	Unit	Other
<b>20</b>	<b>Contact us</b>	<b>Contact us</b>

### ELECTRICAL CHARACTERISTICS

Impedance	<b>50</b>	Ω
Frequency	<b>0-3</b>	GHz
VSWR	<b>1.10 + 0,0000</b>	x F(GHz) Maxi
Insertion loss	<b>0.05</b>	√F(GHz) dB Maxi
RF leakage	- ( <b>NA</b> )	- F(GHz)) dB Maxi
Voltage rating	<b>1270</b>	Veff Maxi
Dielectric withstanding voltage	<b>2000</b>	Veff mini
Insulation resistance	<b>10000</b>	MΩ mini

### MECHANICAL CHARACTERISTICS

Center contact retention		
Axial force – Mating End	<b>200</b>	N mini
Axial force – Opposite end	<b>50</b>	N mini
Torque	<b>NA</b>	N.cm mini
Recommended torque		
Mating	<b>3500</b>	N.cm
Panel nut	<b>NA</b>	N.cm
Clamp nut	<b>950</b>	N.cm
A/F clamp nut	<b>19,0000</b>	mm
Mating life	<b>100</b>	Cycles mini
Weight	<b>156,2000</b>	g

### ENVIRONMENTAL

Operating temperature	<b>-40/+85</b>	°C
Hermetic seal	<b>NA</b>	Atm.cm3/s
Panel leakage	<b>NA</b>	

### SPECIFICATION

### CABLE ASSEMBLY

Stripping	a	b	c	d	e	f
mm	<b>10</b>	<b>27</b>	<b>0</b>	<b>0</b>	<b>0</b>	<b>0</b>

Assembly instruction:

Recommended cable(s)

**FSJ4RN-50B**  
**M2839Z**  
**M2830Z**

Characteristics indicated on this data sheet are those that can be achieved with the highest performance cable. Intrinsic limitations of the cable may diminish the performance of the assembly

Cable retention

- pull off	<b>350</b>	N mini
- torque	<b>NA</b>	N.cm

### TOOLING

Part Number	Description	Hexagon
R282010050	STRIPPING TOOL	
R282303220	TORQUE SPANNER .708 in 84.075 in.lb	

### OTHER CHARACTERISTICS

**Watertightness:IP67**