

**N FEMALE - UHF MALE STRAIGHT ADAPTER**

**R191.733.000**

Série : ADAPT

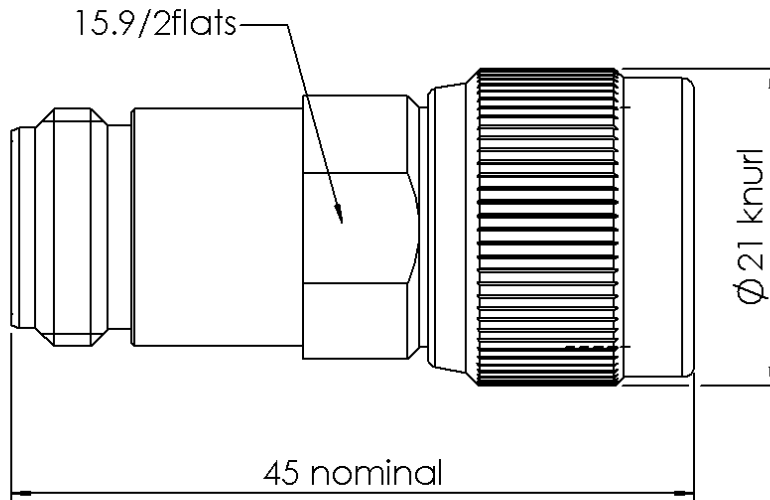

All dimensions are in mm.

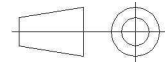

COMPONENTS	MATERIALS	PLATING (µm)
<b>BODY</b>	<b>BRASS</b>	<b>NICKEL 2</b>
<b>CENTER CONTACT</b>	<b>BERYLLIUM COPPER</b>	<b>GOLD 0.5 OVER NICKEL 2</b>
<b>OUTER CONTACT</b>	<b>BRASS</b>	<b>NICKEL 2</b>
<b>INSULATOR</b>	<b>PTFE</b>	
<b>GASKET</b>	-	
<b>OTHERS PARTS</b>	<b>BRASS</b>	<b>NICKEL 2</b>
-	-	-
-	-	-

**Issue : 1013 N**

In the effort to improve our products, we reserve the rights to make changes judged to be necessary.



**N FEMALE - UHF MALE STRAIGHT ADAPTER**

**R191.733.000**

Série : ADAPT

**PACKAGING**

**SPECIFICATION**

Standard	Unit	Other
	<b>'W' option</b>	<b>Contact us</b>

**ELECTRICAL CHARACTERISTICS**

**ENVIRONMENTAL**

Impedance	<b>50</b>	$\Omega$
Frequency	<b>0-0.5</b>	GHz
VSWR	- + <b>0,0000</b>	x F(GHz) Maxi
Insertion loss		- $\sqrt{F}$ (GHz) dB Maxi
RF leakage	- (	- F(GHz)) dB Maxi
Voltage rating		- Veff Maxi
Dielectric withstanding voltage	<b>1500</b>	Veff mini
Insulation resistance	<b>5000</b>	M $\Omega$ mini

Operating	<b>-55/+155</b>	$^{\circ}$ C
Hermetic seal	<b>NA</b>	Atm.cm3/s
Panel leakage	<b>NA</b>	

**MECHANICAL CHARACTERISTICS**

**OTHER CHARACTERISTICS**

Center contact retention		
Axial force – Mating end	<b>27</b>	N mini
Axial force – Opposite end	<b>27</b>	N mini
Torque	<b>NA</b>	N.cm mini
Recommended torque		
Mating	<b>UHF</b>	<b>0</b> N.cm
	<b>N</b>	<b>0</b> N.cm
	<b>-</b>	<b>0</b> N.cm
Panel nut	<b>NA</b>	N.cm
Mating life	<b>500</b>	Cycles mini
Weight	<b>59,0000</b>	g

Issue : 1013 N

In the effort to improve our products, we reserve the rights to make changes judged to be necessary.

