

8MM DUPLEX R3C MALE HOUSING+CRIMP SLEEVE

R197.235._82

Series: **SMB CARLOCK**

To obtain th complete P/N please fill in the blank "_" with the coding letter

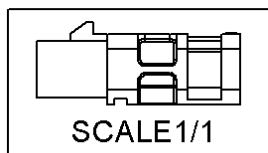
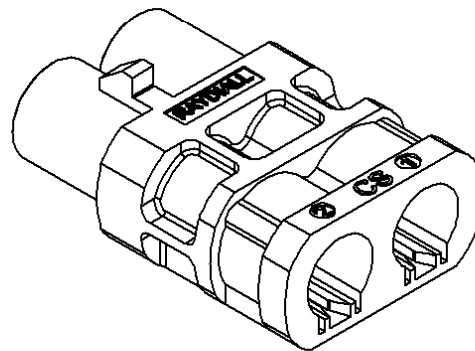
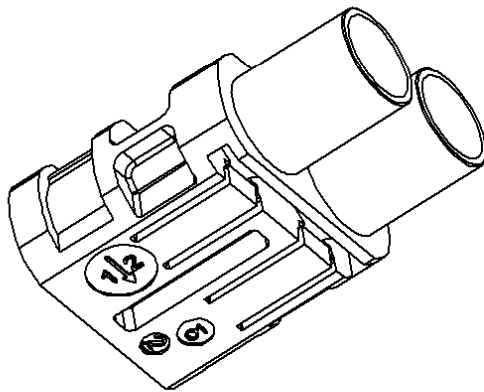
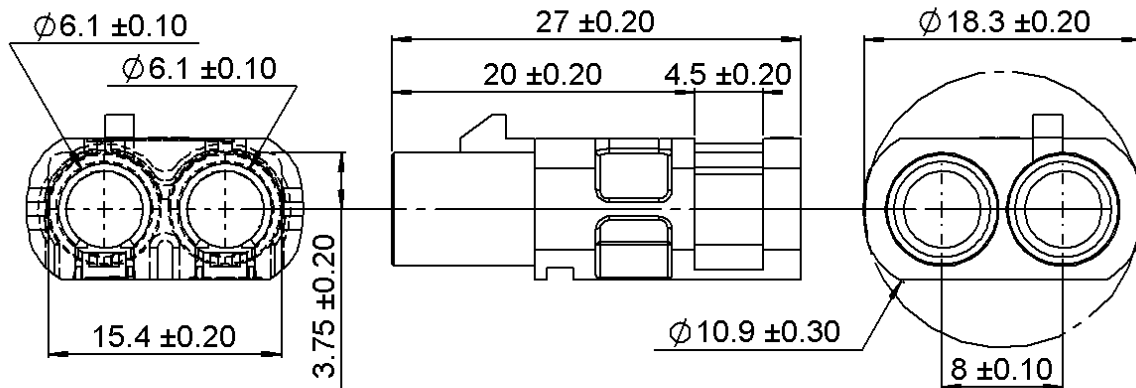

Housing to be used with:

R299.197.000 + R299.197.900
R299.197.010 + R299.197.900

All dimensions are in mm.

COMPONENTS	MATERIALS	PLATING	
		UL CLASSIFICATION	COLOR
HOUSING	PA6.6 GF15 (POLYAMIDE)	UL 94 V-2	(µm)
			See Page2

PACKAGING

Standard	Other
3000	Contact us

MECHANICAL CHARACTERISTICS

Mating life **100** Cycles mini
 Weight **1,91** g

ENVIRONMENTAL

Operating temperature **-40/+110 °C**

Issue : 1609 A

In the effort to improve our products, we reserve the right to make changes judged to be necessary.



8MM DUPLEX R3C MALE HOUSING+CRIMP SLEEVE

R197.235._82

Series: **SMB CARLOCK**

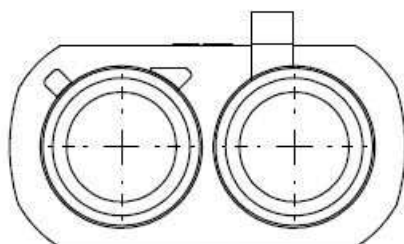

CODING A
COLOR BLACK
RAL9005

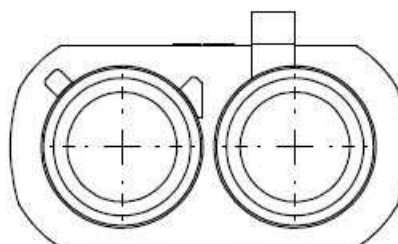

CODING B
COLOR WHITE
RAL9001

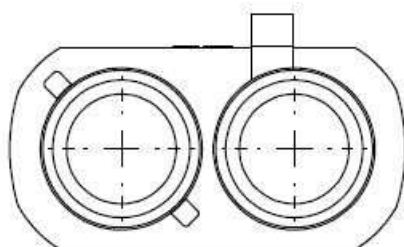

CODING C
COLOR BLUE
RAL5005

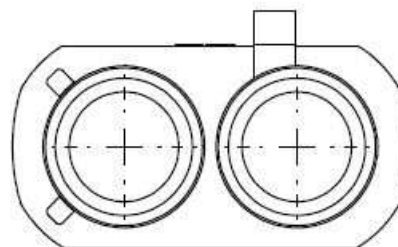

CODING D
COLOR VIOLET
RAL4004

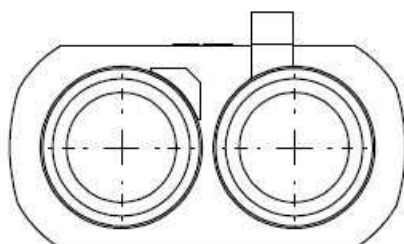

CODING E
COLOR GREEN
RAL6002

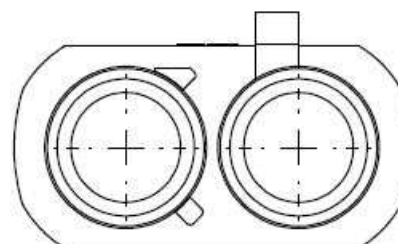

CODING F
COLOR BROWN
RAL8011

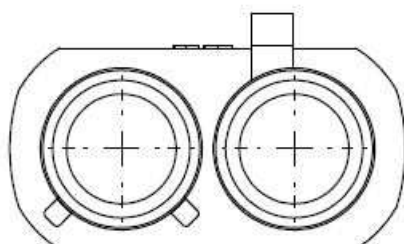

CODING K
COLOR CURRY
RAL1027

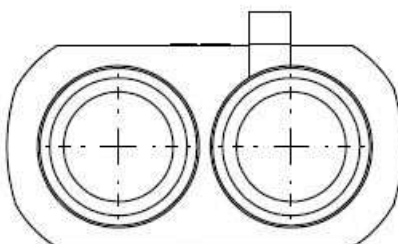

CODING Z
COLOR WHITE
RAL5021

-For other Coding, please contact us

-To obtain the complete P/N please fill in the blank " _ " with the coding letter

Issue : 1609 A

In the effort to improve our products, we reserve the right to make changes judged to be necessary.



8MM DUPLEX R3C MALE HOUSING+CRIMP SLEEVE

R197.235._82

Series: SMB CARLOCK

RECOMMENDED MOUNTING PROCEDURE

1

● **Pre-insertion of the coax into the housing**

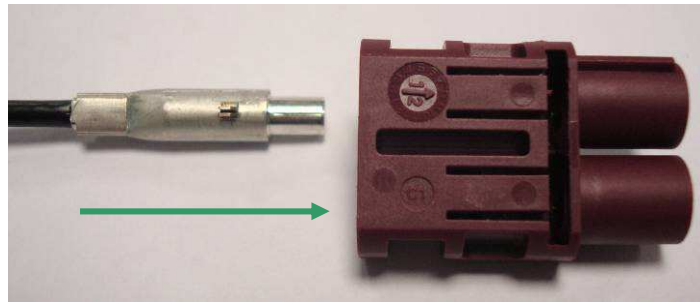

● **Orientation of the tab of the coax with the slot of the housing.**

Orientation of the slot

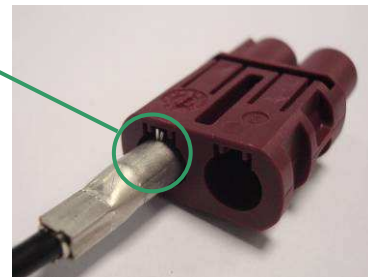

2

● **Push the connector into the housing until it clip on.**

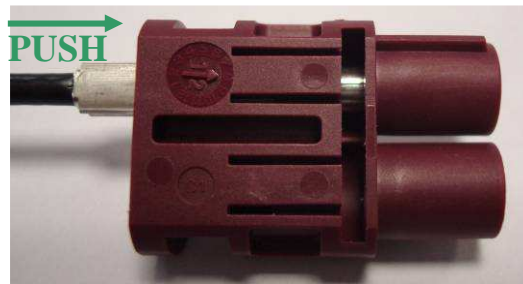

● **Rotate the coax 180° into the housing to insure the positioning**

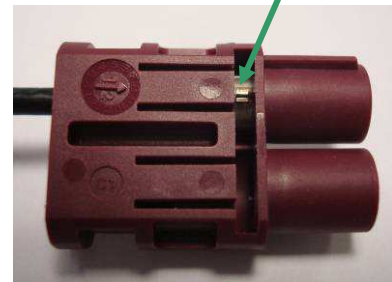

● **Repeat the operation 1 and 2 to insert the coax into the second way.**

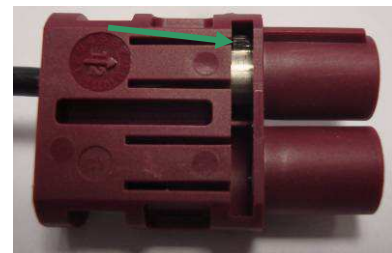

Issue : 1609 A

In the effort to improve our products, we reserve the right to make changes judged to be necessary.