

SCREW STRAIGHT RECEPTACLE
FRONT MOUNT-WITH CYLINDRICAL CONTACT

R199.012.504

Series : MCC #12

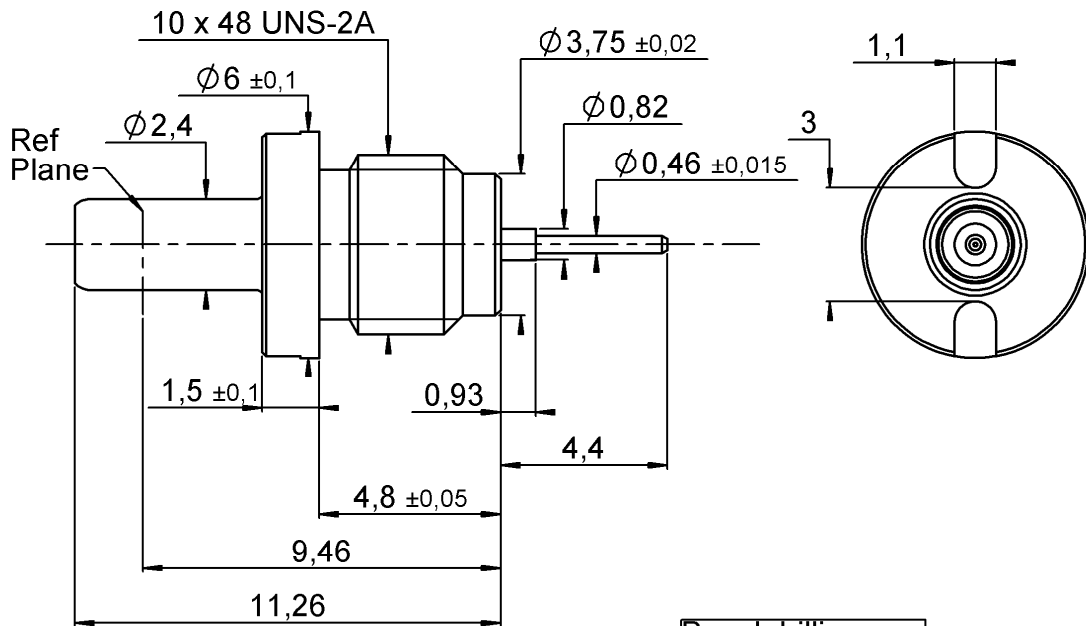

Panel drilling
 Usinage panneau

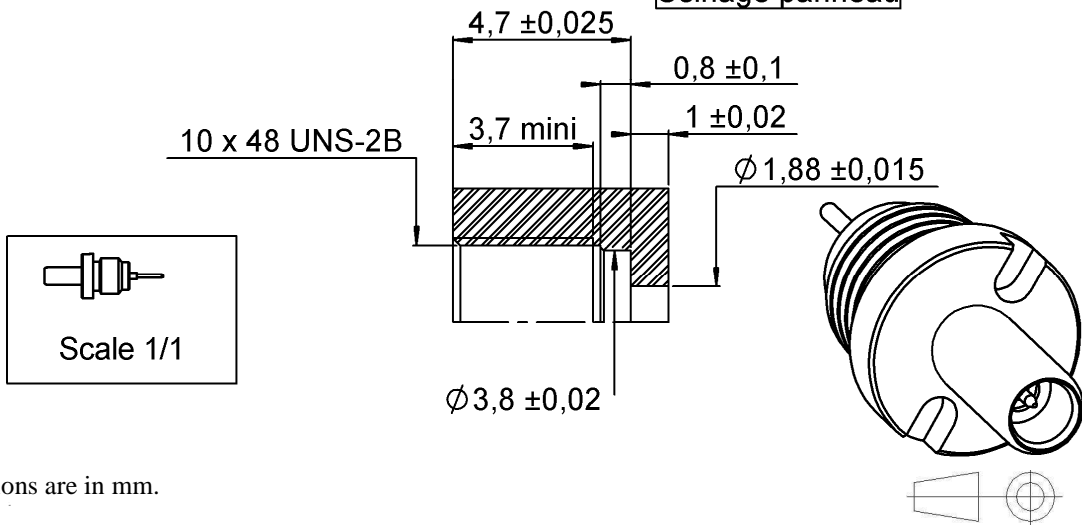

All dimensions are in mm.

COMPONENTS	MATERIALS	PLATING (µm)
BODY	BRONZE	GOLD 1.3 OVER NICKEL2
CENTER CONTACT	BERYLLIUM COPPER	GOLD 1.3 OVER NICKEL2
OUTER CONTACT	-	-
INSULATOR	PTFE+PEEK	-
GASKET	-	-
OTHERS PARTS	BERYLLIUM COPPER	GOLD 0.5 OVER NICKEL 2
-	-	-
-	-	-

Issue : 1245 A

In the effort to improve our products, we reserve the right to make changes judged to be necessary.



SCREW STRAIGHT RECEPTACLE

R199.012.504

FRONT MOUNT-WITH CYLINDRICAL CONTACT

Series : MCC #12

PACKAGING

SPECIFICATION

Standard	Unit	Other
100	-	Contact us

ELECTRICAL CHARACTERISTICS

ENVIRONMENTAL

Impedance	50	Ω
Frequency	0-18	GHz
VSWR	1.1 + 0,0050	x F(GHz) Maxi
Insertion loss	0.1	$\sqrt{F(GHz)}$ dB Maxi
RF leakage	- (*80)	- F(GHz)) dB Maxi
Voltage rating	335	Veff Maxi
Dielectric withstanding voltage	1000	Veff mini
Insulation resistance	5000	M Ω mini

Operating temperature	-65/+165	$^{\circ}$ C
Hermetic seal	NA	Atm.cm3/s
Panel leakage	NA	

OTHER CHARACTERISTICS

Assembly instruction **NA**

Others :
 *DC-3 GHz
 3 GHz to 26 GHz : -65 dB

MECHANICAL CHARACTERISTICS

Center contact retention		
Axial force – Mating end	6.7	N mini
Axial force – Opposite end	6.7	N mini
Torque	NA	N.cm mini
Recommended torque		
Mating	NA	N.cm
Panel nut	90	N.cm
Mating life	500	Cycles mini
Weight	0,9500	g

Issue : 1245 A

In the effort to improve our products, we reserve the right to make changes judged to be necessary.

