



R2005280L

CATV Reverse Hybrid 200MHz 28dB

Product Description

The R2005280L is a Hybrid Reverse amplifier. The part employs a Silicon die and is operated from 5 MHz to 200 MHz or 210 MHz. It provides excellent linearity and superior return loss performance with low noise and optimal reliability.



Package: SOT-115J

Functional Block Diagram

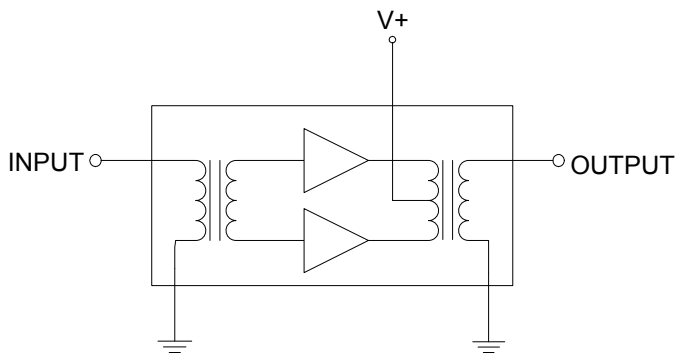

Product Features

- Excellent Linearity
- Superior Return Loss Performance
- Extremely Low Distortion
- Optimal Reliability
- Low Noise
- Unconditionally Stable Under all Terminations
- 28.3 dB Typ. Gain at 210 MHz
- 140 mA Max. at 24 VDC

Applications

- 5–200 MHz CATV Amplifier for Reverse Channel Systems

Ordering Information

Part No.	Description
R2005280L	Box with 50 pcs

R2005280L Absolute Maximum Ratings

Parameter	Value / Range
RF Input Voltage (single tone)	65 dBmV
DC Supply over-voltage (5 minutes)	+30 V
Storage Temperature	-40 to 100 °C
Operating Mounting Base Temperature	-30 to 100 °C

Operation of this device outside the parameter ranges given above may cause permanent damage.

Electrical Specifications

Parameter	Test Conditions: V+=24V, T _{MB} =30°C, Z _S =Z _L =75Ω	Min	Typ	Max	Unit
Operational Frequency Range	–	5	–	210	MHz
Gain	f _o = 5 MHz	27.5	28.2	28.5	dB
Gain	f _o = 200 MHz	27.3	28.3		
Gain	f _o = 210 MHz	27.3	28.3		
Gain Slope	f _o = 5 to 200 MHz ^[1]	-0.2	0.1	0.5	
Gain Slope	f _o = 5 to 210 MHz ^[1]	-0.2	0.1	0.5	
Gain Flatness	f _o = 5 to 200 MHz			±0.3	
Gain Flatness	f _o = 5 to 210 MHz			±0.3	
Input Return Loss	f _o = 5 to 200 MHz f _o = 200 to 210 MHz	20.0 20.0		– –	
Output Return Loss	f _o = 5 to 200 MHz f _o = 200 to 210 MHz	20.0 20.0		– –	dB
Noise Figure	f _o = 200 MHz f _o = 210 MHz	– –	4.9 5.0	5.2 5.2	
IDC		130	135	140	mA
CTB				-69	dBc
XMOD	V _O = 50.0dBmV, 7 channels flat ^[2]			-65	dBc
CSO				-70	dBc
d2		^[3]			-60
Vo	D _{IM} = -60dB ^[4]	61			dBmV

- The slope is defined as the difference between the gain at the start frequency and the gain at the stop frequency.
- 7 analog channels, NTSC frequency raster: T7-T13 (7.00MHz to 43.00MHz), +50dBmV flat output level.
- f1 = 83.25MHz; V1 = 50dBmV; f2 = 109.25MHz; V2 = 50dBmV; f-TEST = f1 + f2 = 192.5MHz.
- f1 = 187.25MHz; V1 = 50dBmV; f2 = 149.25MHz; V2 = V1 - 6dB; f3 = 196.25MHz; V3 = V1 - 6dB; f-TEST = f1 + f2 - f3 = 185.25MHz according to DIN45004B.
- Composite Triple Beat (CTB) - The CTB parameter is defined by ANSI/SCTE 6.
Composite Second Order (CSO) - The CSO parameter (both sum and difference products) is defined by ANSI/SCTE 6.
Cross Modulation (XMOD) - Cross modulation (XMOD) is defined by ANSI/SCTE 58, measured at baseband (selective voltmeter method), referenced to 100% modulation of the carrier being tested.

Package Drawing (Dimensions in millimeters)

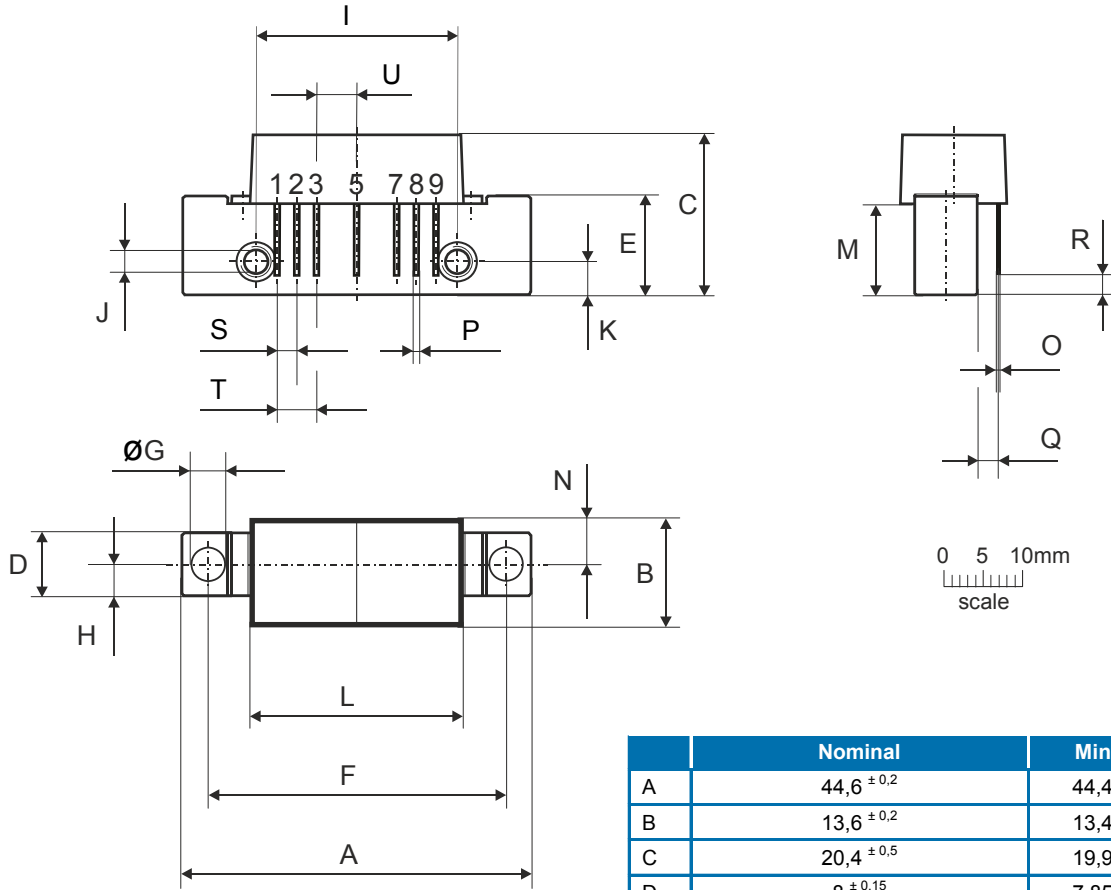

Notes:

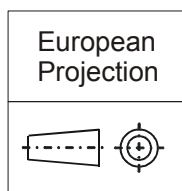

Pinning:

Pin	Name
1	Input
2-3	GND
4	
5	V+
6	
7-8	GND
9	Output

	Nominal	Min	Max
A	44,6 ± 0,2	44,4	44,8
B	13,6 ± 0,2	13,4	13,8
C	20,4 ± 0,5	19,9	20,9
D	8 ± 0,15	7,85	8,15
E	12,6 ± 0,15	12,45	12,75
F	38,1 ± 0,2	37,9	38,3
G	4 ^{+0,2/-0,05}	3,95	4,2
H	4 ± 0,2	3,8	4,2
I	25,4 ± 0,2	25,2	25,6
J	UNC 6-32	-	-
K	4,2 ± 0,2	4,0	4,4
L	27,2 ± 0,2	27,0	27,4
M	11,6 ± 0,5	11,1	12,1
N	5,8 ± 0,4	5,4	6,2
O	0,25 ± 0,02	0,23	0,27
P	0,45 ± 0,03	0,42	0,48
Q	2,54 ± 0,3	2,24	2,84
R	2,54 ± 0,5	2,04	3,04
S	2,54 ± 0,25	2,29	2,79
T	5,08 ± 0,25	4,83	5,33
U	5,08 ± 0,25	4,83	5,33