



RADIALL
Coaxial connectors

TECHNICAL DATA

R 203 313

Issue : 9211

Page

STRAIGHT BULKHEAD JACK
CRIMP TYPE CABLE 2/50

SERIES: SSMB 1

/ 2

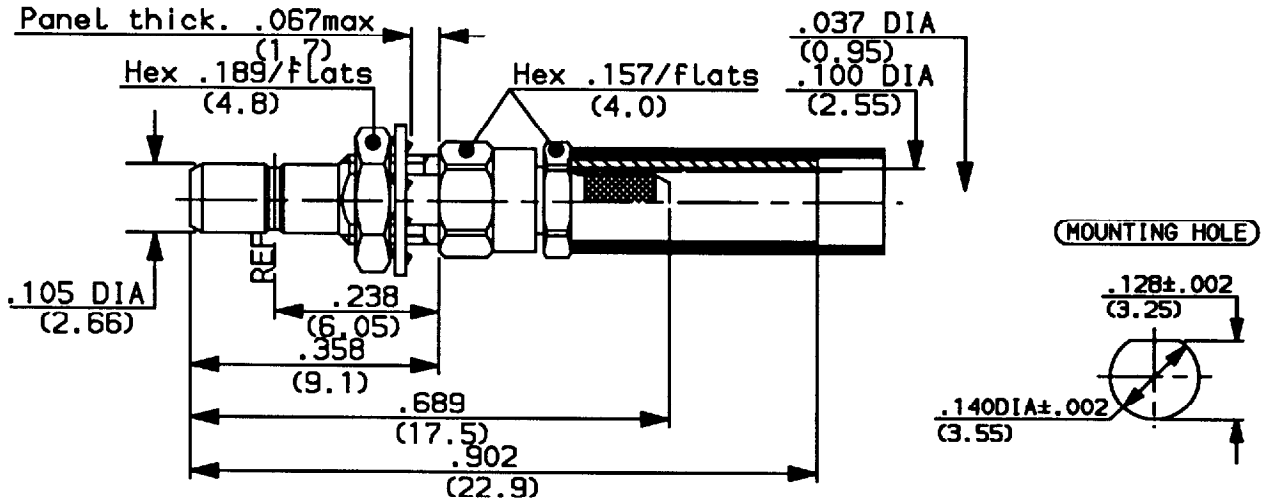

CHARACTERISTICS

NOMINAL IMPEDANCE	50 Ω
FREQUENCY RANGE	0-4 GHz
TEMPERATURE RATING	-65/+165 °C
VSWR	1.33 Max
RF INSERTION LOSS	0.30 /F dB MaxI
VOLTAGE RATING	250 V _{rms} MaxI
DIELECTRIC WITHSTANDING VOLTAGE	500 V _{rms} minI
INSULATION RESISTANCE	1000 M Ω minI
HERMETIC SEAL	NA cc/s - Atm.cm ³ /s
LEAKAGE (pressurized only)	NA psi - MPa

STANDARDISATION

MIL STD 348A
CEI 169-19
CECC 22170

CABLE RETENTION	9.9 lb minI 45 N
CENTER CONTACT RETENTION	
Axial force - mating end	2.0 lb minI 8.9 N
Axial force - opposite end	2.0 lb minI 8.9 N
Torque (Min)	NA - Inch.oz cm.N
RECOMMENDED TORQUES	
Mating	NA - Inch. Lb cm.N
Panel nut	2.2125 25 Inch. Lb cm.N
Clamp nut	NA - Inch. Lb cm.N

CONSTRUCTION

CONNECTOR PARTS	MATERIALS	FINISH
BODY	BRASS	20 μ I GOLD
OUTER CONTACT	BRASS	20 μ I GOLD
CENTER CONTACT	BERYLLIUM COPPER	50 μ I GOLD
INSULATORS	PTFE	-
BACK BODY	BRASS	20 μ I GOLD
FERRULE	BRASS	8 μ I GOLD
HEATSHRINK SLEEVE	POLYOLEFINE	-
-	-	-