

TWO HOLE FLANGE MALE JACK
LIMITED DETENT SOLDER TYPE CABLE .085

R222.252.301

Series : SMP

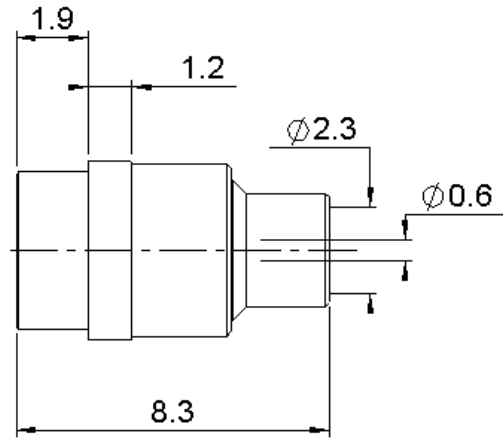
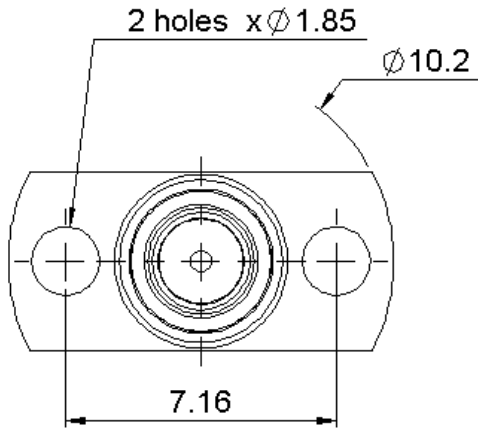

PANEL CUT OUT

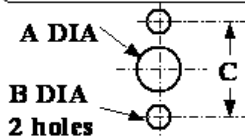

	mm	
	Maxi	mini
A	4.8	4.7
B	1.9	1.8
C	7.2	7.1

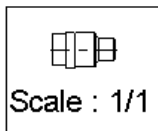
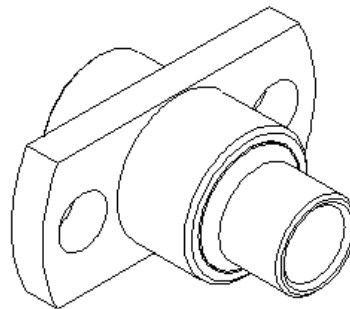

All dimensions are in mm.



COMPONENTS	MATERIALS	PLATINGS (µm)
BODY	STAINLESS STEEL + BRASS	PASSIVATED + GOLD1.3 OVER NICKEL2
CENTER CONTACT	BERYLLIUM COPPER	GOLD 1.27 OVER NICKEL 1.27
OUTER CONTACT		
INSULATOR	PTFE	
GASKET		
OTHERS PARTS	-	-
-	-	-
-	-	-

Issue : 0529 C

In the effort to improve our products, we reserve the right to make changes judged to be necessary.



TWO HOLE FLANGE MALE JACK
LIMITED DETENT SOLDER TYPE CABLE .085

R222.252.301

Series : SMP

PACKAGING

Standard	Unit	Other
100	'W' option	Contact us

SPECIFICATION

ELECTRICAL CHARACTERISTICS

Impedance		50 Ω
Frequency		0-40 GHz
VSWR	1.50 +	0.000 x F(GHz) Maxi
Insertion loss		0.12 √F(GHz) dB Maxi
RF leakage	- (* - F(GHz)) dB mini
Voltage rating		335 Veff Maxi
Dielectric withstanding voltage		500 Veff mini
Insulation resistance		5000 MΩ mini

CABLE ASSEMBLY

Stripping	a	b	c	d	e	f
mm	1.30	0.00	0.00	0.00	0.00	0.00

Assembly instruction :

Recommended cable(s)
 RG 405
 KS 1

Cable retention

- pull off **200** N mini
- torque **NA** N.cm

MECHANICAL CHARACTERISTICS

Center contact retention		
Axial force – Mating end	NA	N mini
Axial force – Opposite end	NA	N mini
Torque	NA	N.cm mini
Recommended torque		
Mating	NA	N.cm
Panel nut	NA	N.cm
Clamp nut	NA	N.cm
A/F clamp nut	0.000	mm
Mating life	500	Cycles mini
Weight	0.753	g

TOOLING

Part Number	Description	Hexagon
.	.	.
R282.051.000	STRIPPING TOOL	
R282.062.010	POINTER GAUGE	
R282.740.030	SOLDERING MOUNTING	
R282.743.100	POSITIONER FOR SOLDERING SMP	
R282.744.254	POSITIONER FOR SOLDERING SMP	
R282.862.120	SOLDER GAUGE THCK 1.83	

ENVIRONMENTAL

Operating temperature	-65/+165	° C
Hermetic seal	NA	Atm.cm3/s
Panel leakage	NA	

OTHERS CHARACTERISTICS

*RF leakage:-80dB DC-3 GHz
 -65dB 3-26.5 GHz
 Compliant with MIL-STD-348

Issue : 0529 C

In the effort to improve our products, we reserve the right to make changes judged to be necessary.

