

**TWO HOLE FLANGE SHROUD 0.4MM**

**R222.450.321**

**LIMITED DETENT**

Series : SMP

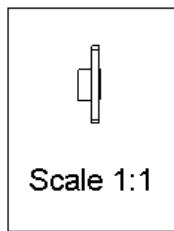
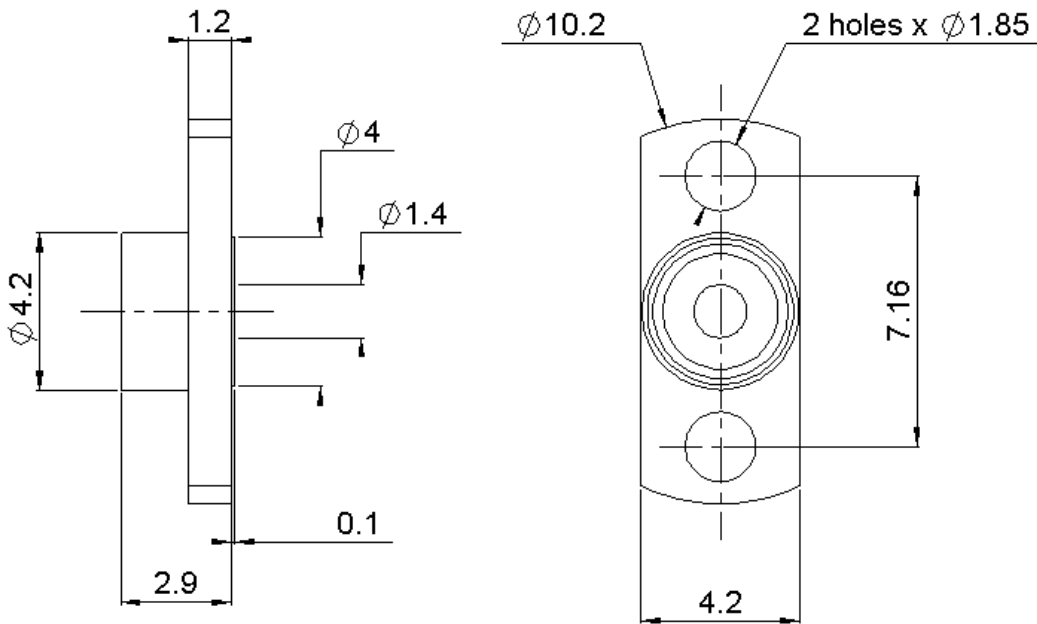

**PANEL CUT OUT**

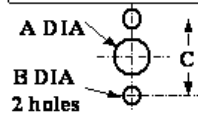

	mm	
	Maxi	mini
A	4.15	4.05
B	1.90	1.80
C	7.21	7.11

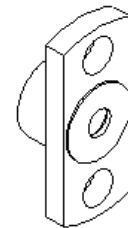

All dimensions are in mm.



COMPONENTS	MATERIALS	PLATINGS (µm)
BODY	STAINLESS STEEL	PASSIVATED .
CENTER CONTACT		
OUTER CONTACT		
INSULATOR		
GASKET		
OTHERS PARTS		
-	-	-
-	-	-

Issue : 0529 B

In the effort to improve our products, we reserve the right to make changes judged to be necessary.



**TWO HOLE FLANGE SHROUD 0.4MM**

**R222.450.321**

**LIMITED DETENT**

Series : SMP

**PACKAGING**

**SPECIFICATION**

Standard	Unit	Other
<b>100</b>	<b>'W' option</b>	<b>Contact us</b>

**ELECTRICAL CHARACTERISTICS**

**ENVIRONMENTAL**

Impedance		NA	$\Omega$
Frequency		NA	GHz
VSWR	NA +	<b>0.000</b>	x F(GHz) Maxi
Insertion loss		NA	$\sqrt{F}$ (GHz) dB Maxi
RF leakage	- (	NA	- F(GHz)) dB Maxi
Voltage rating		NA	Veff Maxi
Dielectric withstanding voltage		NA	Veff mini
Insulation resistance		NA	M $\Omega$ mini

Operating temperature	<b>-65/165</b>	$^{\circ}$ C
Hermetic seal	NA	Atm.cm <sup>3</sup> /s
Panel leakage	NA	

**OTHERS CHARACTERISTICS**

Assembly instruction

Others :

**MECHANICAL CHARACTERISTICS**

Center contact retention			
Axial force – Mating end	NA	N	mini
Axial force – Opposite end	NA	N	mini
Torque	NA	N.cm	mini
Recommended torque			
Mating	NA	N.cm	
Panel nut	NA	N.cm	
Mating life	<b>500</b>	Cycles	mini
Weight	<b>0.336</b>	g	

Issue : 0529 B

In the effort to improve our products, we reserve the right to make changes judged to be necessary.

