

FEMALE-FEMALE ADAPTER

R222.705.210

Series : **SMP**

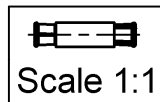
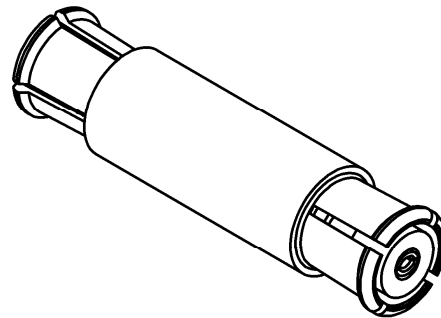
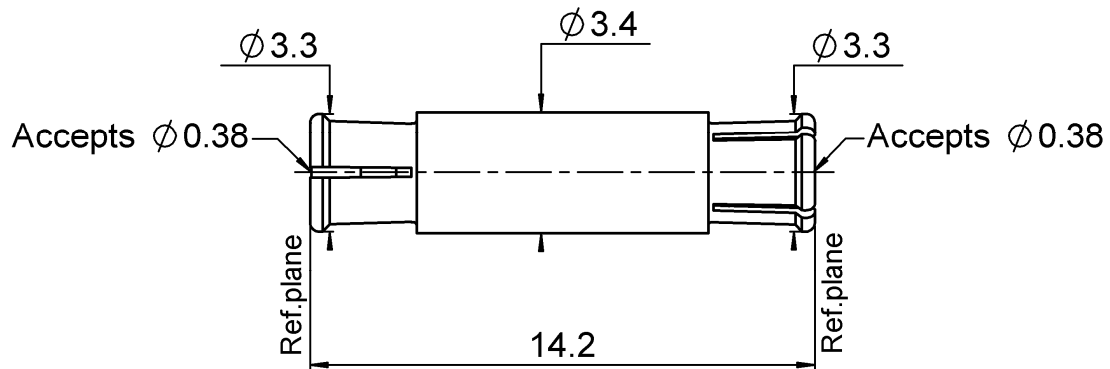

All dimensions are in mm.

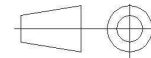

COMPONENTS	MATERIALS	PLATING (μm)
BODY	BERYLLIUM COPPER	NPGR
CENTER CONTACT	BERYLLIUM COPPER	NPGR
OUTER CONTACT		
INSULATOR	PTFE	
GASKET		
OTHERS PARTS		
-	-	-
-	-	-

Issue : 1245 A

In the effort to improve our products, we reserve the right to make changes judged to be necessary.



FEMALE-FEMALE ADAPTER

R222.705.210

Series : **SMP**

PACKAGING

Standard	Unit	Other
100	-	Contact us

SPECIFICATION

**1301-RNT 408 9003 Uen Rev. V . . .
RNT 408 9003/29**

ELECTRICAL CHARACTERISTICS

Impedance **50** Ω
 Frequency **0-18** GHz
 VSWR * + **0.0000** x F(GHz) Maxi
 Insertion loss **0.1** √F(GHz) dB Maxi
 RF leakage - (**NA** - F(GHz)) dB Maxi
 Voltage rating **335** Veff Maxi
 Dielectric withstanding voltage **500** Veff mini
 Insulation resistance **5000** MΩ mini

ENVIRONMENTAL

Operating temperature **-65/+165** ° C
 Hermetic seal **NA** Atm.cm3/s
 Panel leakage **NA**

OTHER CHARACTERISTICS

Assembly instruction **NA**

Others :

- * 0~2GHz: <=-28dB
- * 2~4GHz: <=-30dB
- * 4~18GHz: <=-20dB

MECHANICAL CHARACTERISTICS

Center contact retention
 Axial force – Mating end **6.7** N mini
 Axial force – Opposite end **6.7** N mini
 Torque **NA** N.cm mini

Recommended torque
 Mating **NA** N.cm
 Panel nut **NA** N.cm

Mating life **100** Cycles mini
 Weight **0.6070** g

Issue : 1245 A

In the effort to improve our products, we reserve the right to make changes judged to be necessary.

