

RIGHT ANGLE PLUG CRIMP TYPE

R223.183.000

CABLE 2.6/50 D

Series : MMBX

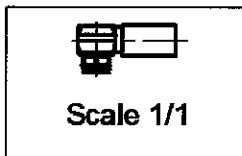
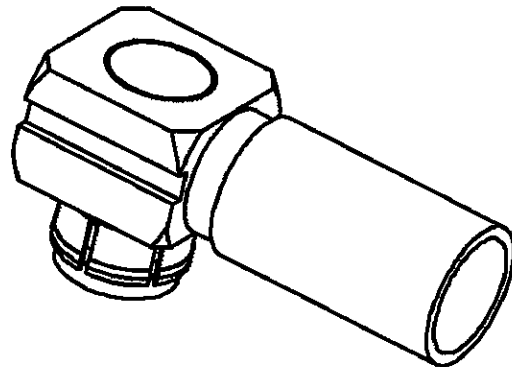
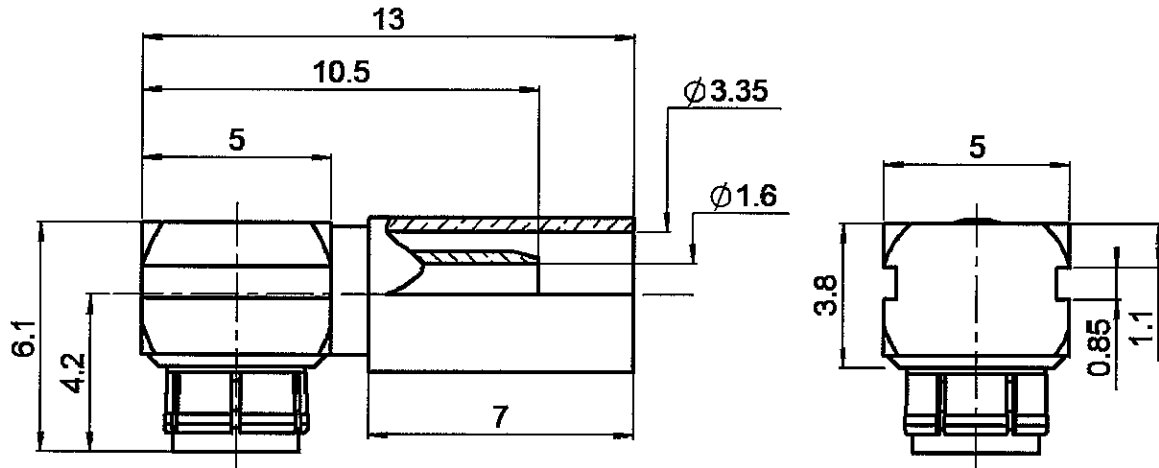

All dimensions are in mm.

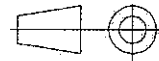

COMPONENTS	MATERIALS	PLATINGS (µm)
BODY	BRASS	GOLD 0.2 OVER NON MAGN NICKEL 2
CENTER CONTACT	BERYLLIUM COPPER, BRASS	GOLD 1.3 OVER NICKEL 2
OUTER CONTACT	BERYLLIUM COPPER	GOLD 0.2 OVER NON MAGN NICKEL 2
INSULATOR	PTFE	
GASKET		
OTHERS PARTS	BRASS	GOLD 0.2 OVER NON MAGN NICKEL 2
-	-	-
-	-	-

Issue : 0452 A

In the effort to improve our products, we reserve the right to make changes judged to be necessary.



RIGHT ANGLE PLUG CRIMP TYPE

R223.183.000

CABLE 2.6/50 D

Series : MMBX

PACKAGING

Standard	Unit	Other
100	'W' option	Contact us

SPECIFICATION

ELECTRICAL CHARACTERISTICS

Impedance		50 Ω
Frequency		0-12.4 GHz
VSWR	1.10 +	0.035 x F(GHz) Maxi
Insertion loss		0.18 √F(GHz) dB Maxi
RF leakage	- (100** - F(GHz)) dB Maxi
Voltage rating		250 Veff Maxi
Dielectric withstanding voltage		750 Veff mini
Insulation resistance		1000 MΩ mini

CABLE ASSEMBLY

Stripping	a	b	c	d	e	f
mm	2.00	4.50	9.50	0.00	7.50	0.00

Assembly instruction :

Recommended cable(s)
K02252D

Cable retention

- pull off **110** N mini
- torque **NA** N.cm

MECHANICAL CHARACTERISTICS

Center contact retention		
Axial force – Mating end	10	N mini
Axial force – Opposite end	10	N mini
Torque	NA	N.cm mini

Recommended torque		
Mating	NA	N.cm
Panel nut	NA	N.cm
Clamp nut	NA	N.cm
A/F clamp nut	0.000	mm

Mating life	100	Cycles mini
Weight	1.000	g

TOOLING

Part Number	Description	Hexagon
.	.	.
R282.235.906	CRIMPING DIES	3.3
R282.293.000	CRIMPING TOOL	
R282.868.000	EXTRACTION ASSEMBLY TOOL	

OTHERS CHARACTERISTICS

* to 6 GHz

** Interface MMBX only up to 2.5 GHz

ENVIRONMENTAL

Operating temperature	-55/+155°	°C
Hermetic seal	NA	Atm.cm3/s
Panel leakage	NA	

Issue : 0452 A

In the effort to improve our products, we reserve the right to make changes judged to be necessary.

