

**GLASS BEAD**  
**PACKAGING 100**

**R280.760.050**

Series : ACC-COAX

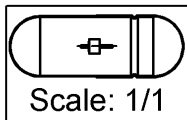
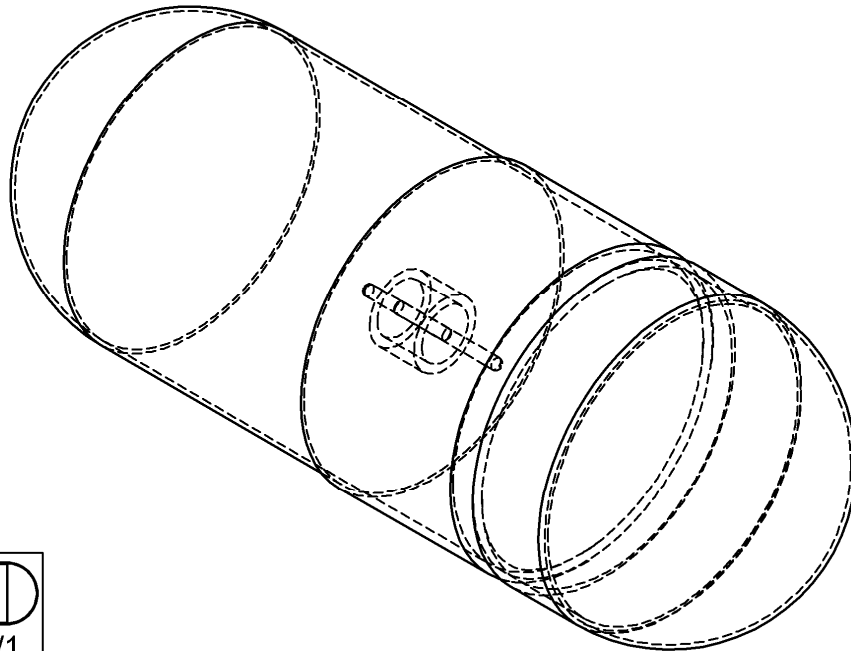
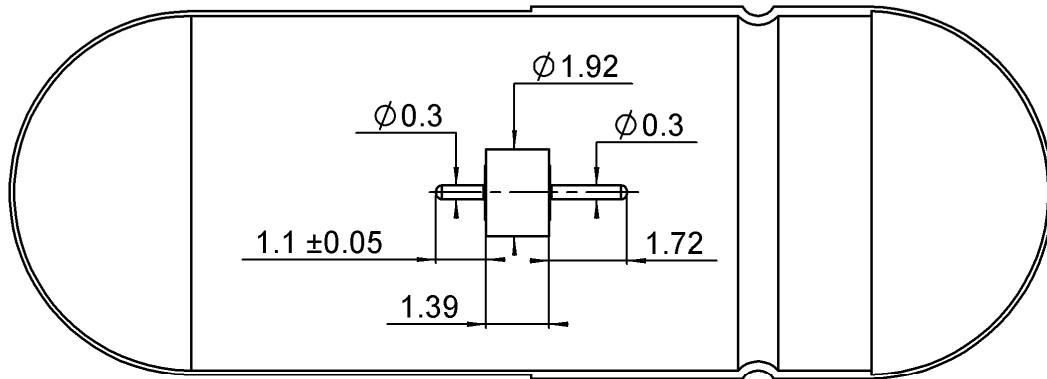

All dimensions are in mm.

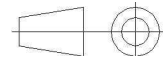

COMPONENTS	MATERIALS	PLATING ( $\mu\text{m}$ )
BODY	DILVER P1	GOLD 0.5 OVER NICKEL 2
CENTER CONTACT	DILVER P1	GOLD 0.5 OVER NICKEL 2
OUTER CONTACT	-	-
INSULATOR	GLASS	-
GASKET	-	-
OTHERS PARTS	-	-

Operating temperature :  $-65/+165$  °C

Weight : 0,0530 g

Others characteristics :

Issue : 1107 A

In the effort to improve our products, we reserve the right to make changes judged to be necessary.



**GLASS BEAD  
PACKAGING 100**

**R280.760.050**

Series : ACC-COAX

PANEL CUT OUT :

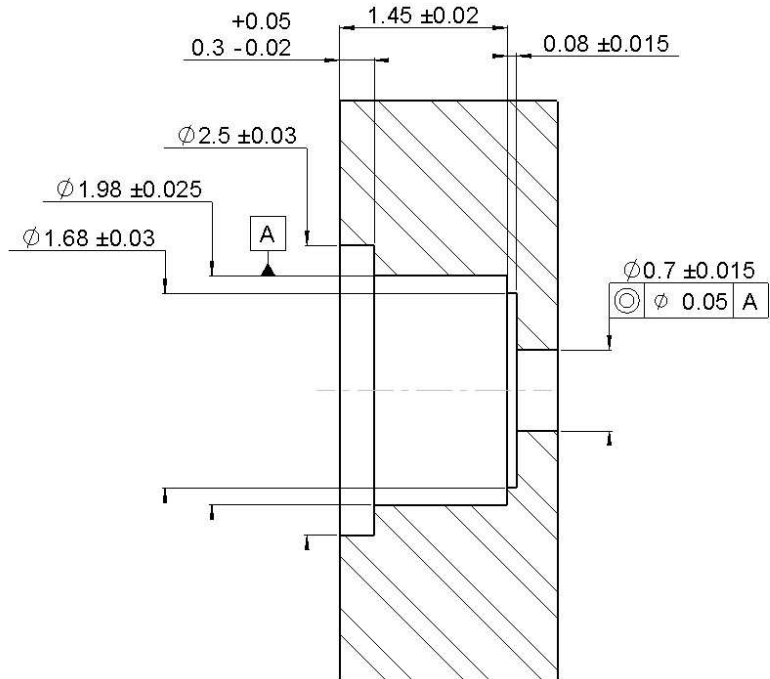

MOUNTING INSTRUCTIONS

- \_ Introduce the glass bead into its housing.
  - \_ Weld the ring by putting a welding wire in the groove.
  - \_ Weld the pin on the track.
- Beware of putting too much welding.

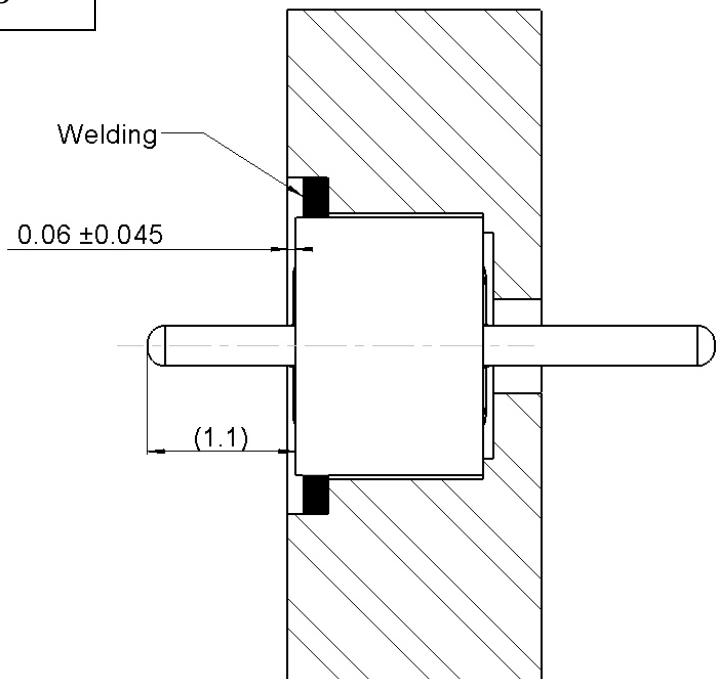

Issue : 1107 A

In the effort to improve our products, we reserve the right to make changes judged to be necessary.

