

## R300 Series

---

### Temperature Sensor



#### DESCRIPTION

The R300 Series is a passive, resistive temperature device (RTD), high temperature probe. This product features a robust, stainless steel closed-tip design that enhances reliability in aggressive environments, while still providing excellent response time.

This one-piece sensor with integral connector was designed for use in heavy duty vehicle engine exhaust gas recirculation (EGR) systems where temperature excursions to 300 °C [572 °F] can occur.

#### FEATURES

- Working temperature range: -40 °C to 275 °C [-40 °F to 527 °F], continuous, excursion to 300 °C [572 °F] for 10 min. max.
- Response time: T63; at 10 m/s gas flow rate at 150 °C [302 °F] ~15 s
- Accuracy: better than  $\pm 3$  °C, -40 °C to 300 °C [-40 °F to 572 °F] typical
- M14 x 1.5 mounting thread
- Enhanced reliability
- Linear output
- Long life

Other potential applications for this harsh duty sensor may include fluid or air temperature sensing within the engine environment or in industrial applications such HVAC or refrigeration compressor equipment where this type of sensor packaging and temperature range is often ideal.

#### POTENTIAL APPLICATIONS

- Exhaust gas temperature sensing systems on heavy duty, truck, agriculture and construction vehicle engines including:
  - In-line fluid temperature sensing
  - Cylinder head temperature sensing
- High temperature industrial or commercial applications including:
  - Bulk refrigeration
  - Domestic heating and controls
  - Hot tub and pool temperature controls
  - Industrial ovens up to 300°C [572 °F]

# R300 Series

FIGURE 1. MOUNTING DIMENSIONS (For reference only: mm/[in])

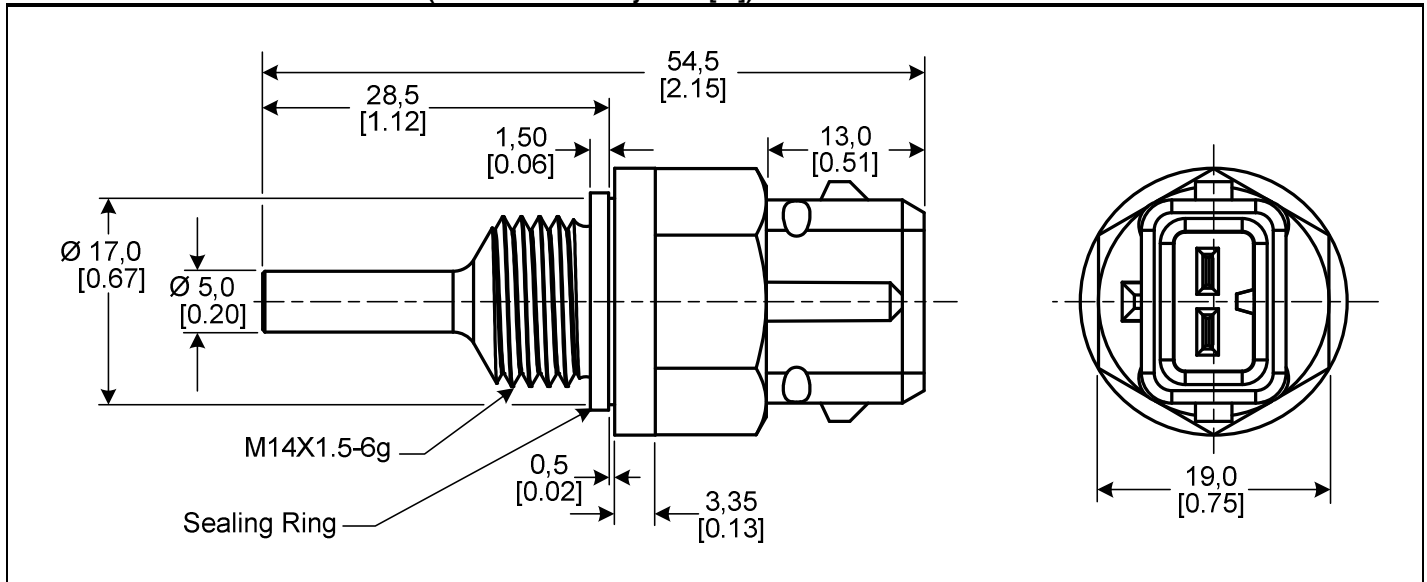
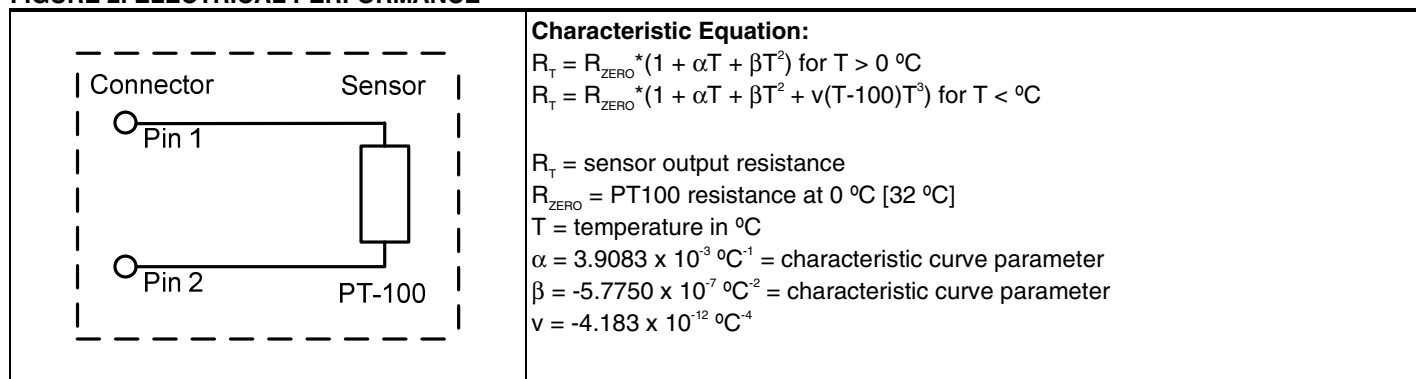

TABLE 1. GENERAL SPECIFICATIONS

Characteristic	Parameter	Note
Insertion depth	28,5 mm [1.12 in]	custom devices available upon request
Sealing surface dimensions	7.0 mm [0.28 in] dia.; 0,5 mm [0.02 in] thickness	—
Mating cable harness connector	AMP JPT/Bosch Jetronics	custom connectors available upon request
Mounting	M14x1.5 male thread, fixing nuts integrated with sensor body	—
Nominal resistance	100 Ohm/0 °C [32 °F]	—
Operating temperature range	-40 °C to 275 °C [-40 °F to 527 °F]	continuous, excursion to 300 °C [572 °F] for 10 min. max.
Accuracy	better than ±3.0 °C	—
Response time	T63; at 10 m/s gas flow rate at 150 °C [302 °F] ~15 s	—
Reliability	Less than or equal to 1.5% failures per one million miles	—
Measurement range continuous probe tip	-40 °C to 275 °C [-40 °F to 527 °F]	—
Measurement range continuous probe body	-40 °C to 250 °C [-40 °F to 482 °F]	—
Storage temperature range	-40 °C to 150 °C [-40 °F to 302 °F]	—
Insulation breakdown	>10 MOhm	100 Vdc for 3 s at room temperature
Torque limits	16 N m [11.8 ft lb] +20%	at room temperature
Housing material	stainless steel	—
Sealing	IP59K	—
Approvals	EN 6071:1996, IEC 751:1983	—

# Temperature Sensor

**FIGURE 2. ELECTRICAL PERFORMANCE**



**TABLE 2. RESISTANCE/TEMPERATURE DATA**

T (Temperature) °C [°F]	Ro (PT100 Resistance) Ohm	T (Temperature) °C [°F]	Ro (PT100 Resistance) Ohm	T (Temperature) °C [°F]	Ro (PT100 Resistance) Ohm
-40 [-40]	84.72	80 [176]	130.90	200 [392]	175.86
-20 [-4]	92.16	100 [212]	138.51	220 [428]	183.19
0 [32]	100	120 [248]	146.07	240 [464]	190.47
20 [68]	107.79	140 [284]	153.58	260 [500]	197.71
40 [104]	115.54	160 [320]	161.05	280 [536]	204.9
60 [140]	123.24	180 [356]	168.48	300 [572]	212.05

**FIGURE 3. CIRCUIT EXAMPLE**

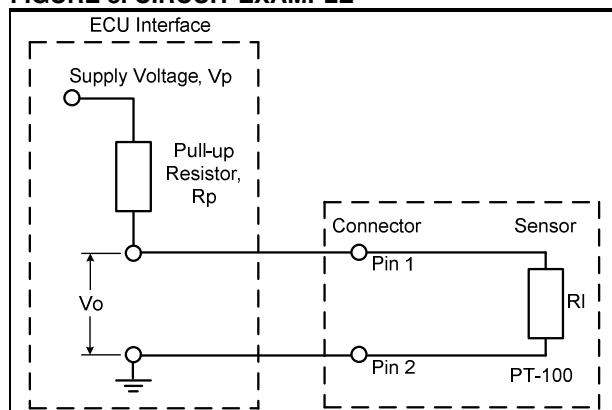

**FIGURE 4. PT100 CLASS B RTD – R/T CURVE**

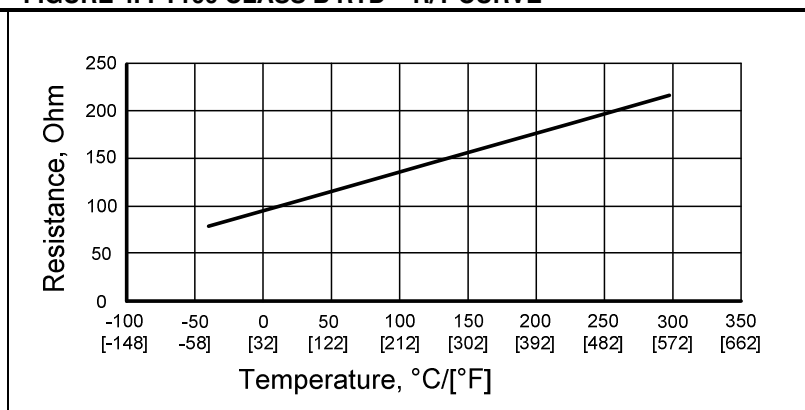

**ORDER GUIDE**

Catalog Listing	Description
R300-F35-M14-C	R300 Series exhaust gas recirculation RTD sensor with stainless steel probe tip, M14 mechanical interface thread and integral connector