

PAGE 1/2

ISSUE 28-06-16

SERIE : SPnT

PART NUMBER : R573013245

## RF CHARACTERISTICS

Number of ways : **12**  
 Frequency range : **0 - 3 GHz**  
 Impedance : **50 Ohms**

Frequency (GHz)	<b>DC - 3</b>
VSWR max	<b>1.35</b>
Insertion loss max	<b>0.50 dB</b>
Isolation min	<b>70 dB</b>
Average power (*)	<b>400 W</b>

## ELECTRICAL CHARACTERISTICS

Actuator : **NORMALLY OPEN**  
 Nominal current \*\* : **102 mA**  
 Actuator voltage (Vcc) : **28V (24 to 30V) / POSITIVE COMMON**  
 Terminals : **44 pins D-SUB male connector**  
 Indicator rating : **1 W / 30 V / 100 mA**

## MECHANICAL CHARACTERISTICS

Connectors : **N female per MIL-C 39012**  
 Life : **2.000.000 cycles per position**  
 Switching Time\*\*\* : **< 15 ms**  
 Construction : **Splashproof**  
 Weight : **< 1100 g**

## ENVIRONMENTAL CHARACTERISTICS

Operating temperature range : **-40°C to +85°C**  
 Storage temperature range : **-55°C to +85°C**

(\* Average power at 25°C per RF Path)

(\*\* At 25° C ±10%)

(\*\*\* Nominal voltage ; 25° C)



DRAWING

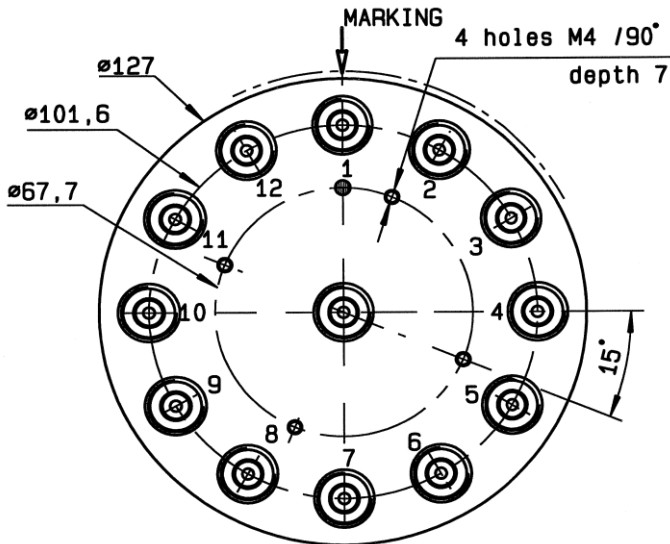

Voltage	RF Continuity	Ind.
+C -1	IN ↔ 1	D.E
+C -2	IN ↔ 2	D.F
+C -3	IN ↔ 3	D.G
+C -4	IN ↔ 4	D.H
+C -5	IN ↔ 5	D.I
+C -6	IN ↔ 6	D.J
+C -7	IN ↔ 7	D.K
+C -8	IN ↔ 8	D.L
+C -9	IN ↔ 9	D.M
+C -10	IN ↔ 10	D.N
+C -11	IN ↔ 11	D.O
+C -12	IN ↔ 12	D.P

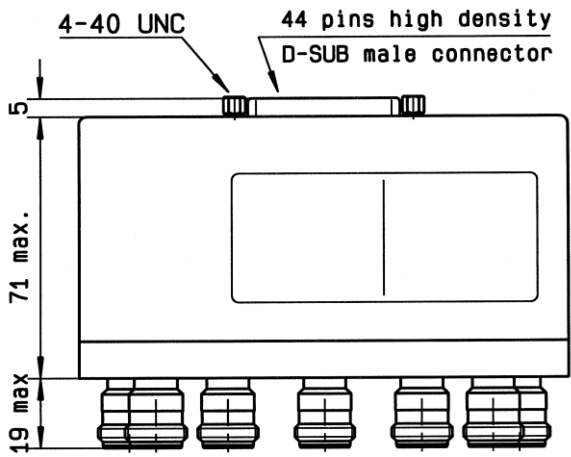

LABEL

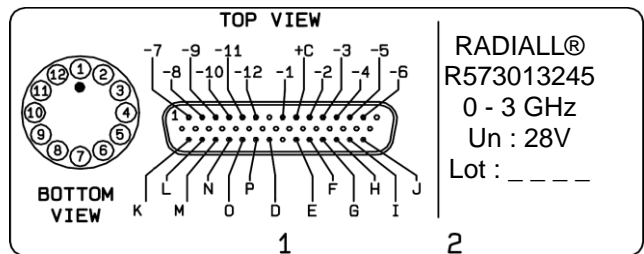

General tolerances : ±0.5 mm

SCHEMATIC DIAGRAM

