

# New 'LOW PIM' COAXIAL SWITCHES

February 2014



*This document and all information contained herein is the sole property of Radiall and is subject to the confidentiality obligations of the recipient.*

*This document shall not be reproduced or disclosed to any third party for any purpose whatsoever or used for manufacturing purposes without prior written agreement from Radiall.*

*No intellectual property rights are granted by the delivery of this document or the disclosure of its content.*

*The statements made herein do not constitute an offer.*

# Table of Contents

- Introduction
- Low PIM range
- Low PIM product information
- Low PIM applications
- Product benefits



# Introduction

# Introduction: What is PIM ?

- Passive Intermodulation (PIM) is a signal distortion that occurs when signals at several frequencies are transmitted through a passive device (connector, cable, switch, antennas...) which has some non-linear response. In return the fundamental frequencies will be distorted and series of higher order harmonic frequencies will appear in the frequency domain. If some of these frequencies appear in the receiving band of a wireless system it will raise the receiver floor noise and reduce the system performance.
- The main sources of intermodulation in wireless systems are the active devices in transceivers and receivers. Their intermodulation can be reduced or eliminated by filtering which is not possible for passive devices inserted in transmissionline. Therefore when intermodulation becomes critical for a system the only solution is to use Low PIM passive devices.

# Introduction: How is PIM Specified?

- If we call  $F_1$  and  $F_2$  the fundamental frequencies (carrier frequencies), then the possible PIM frequencies can be described as follow:

$$F_{\text{PIM}} = n.F_1 \pm m.F_2 \quad n + m \text{ is the order of intermodulation}$$

- For example:  $2F_2 - F_1$  ( $m=2$  and  $n=1$ ) or  $2F_1 - F_2$  results to a 3<sup>rd</sup> order PIM product

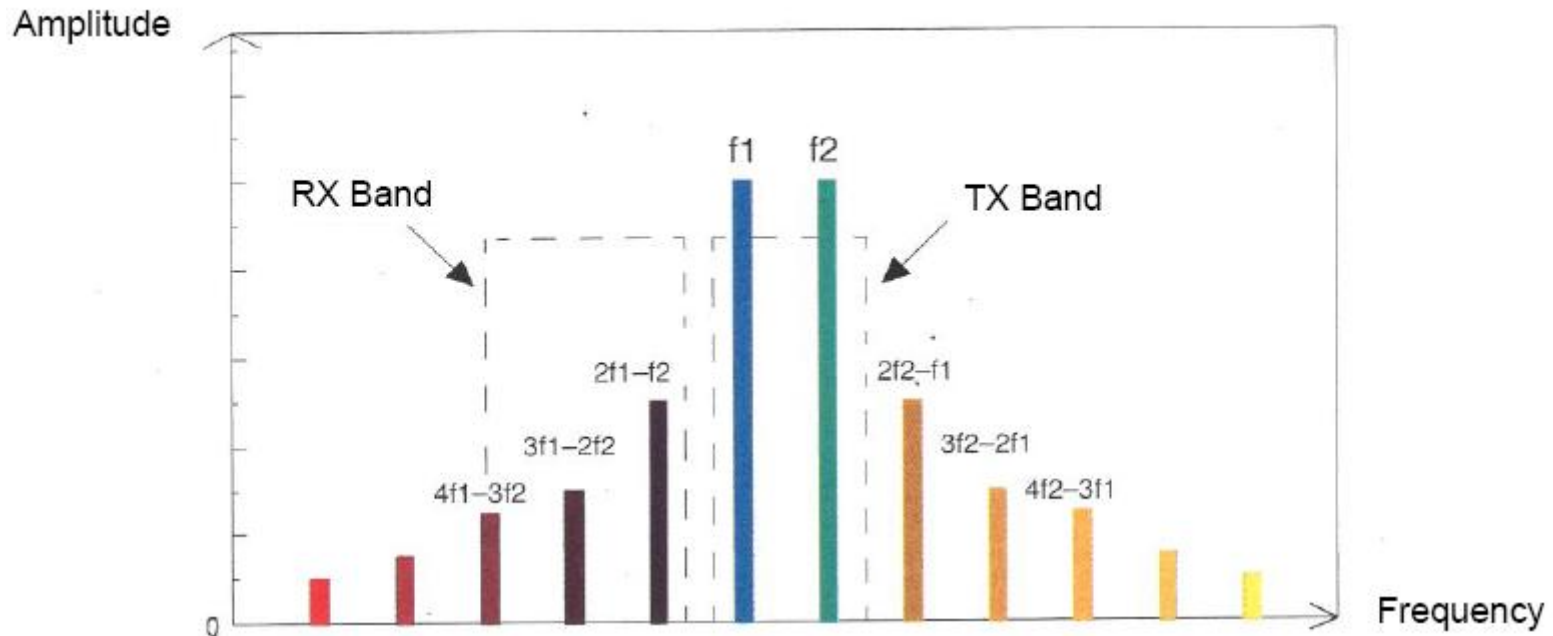

# Introduction: How is PIM Specified?

- Usually odd PIM orders (3<sup>rd</sup>, 5<sup>th</sup>, 7<sup>th</sup> orders) are the main concern because their frequencies are close from the carrier frequency and may disturb the system behavior. As the strength of the signal decreases with the order of PIM, the 3<sup>rd</sup> order is often the most critical and is the one usually tested and specified by component manufacturers.
- PIM is specified in dBc and dBm terms
  - dBm is a measure of power relative to 1mW
  - dBc is a measure of dB below a given carrier level. A typical power level in testing passive devices is +43dBm (20W). In that case if the PIM level is -110dBm, it is equivalent to a PIM level value of:  $-110-43 = -153$ dBc

**A low PIM device has typically a PIM level of -150 to -160 dBc**

# Introduction: Telecom Situation

- Today there is a growing demand on wireless communication devices with higher data rates. 4G or LTE (Long Term Evolution) is the fourth generation standard for mobile phone and allows supplying speeds almost 10 times higher than current networks and providing an answer to this frenetic growth of data consumption. The deployment of 4G networks is designed to cope with the explosion of mobile use. Data volumes on the network operator at Orange status, and have been multiplied by 68 in 5 years and will continue to grow by a factor of 7 by 2015
- This exploding demand will request wireless and RF systems to be very reliable and to work with their full coverage capacity. Since PIM could seriously impact their performances, the low PIM devices will be of high interest for wireless and RF Test industry.



A world map where the landmasses are filled with a dense pattern of small, light blue icons. These icons include various symbols such as airplanes, buildings, gears, and abstract shapes, representing a global network or industry.

# Low PIM Range

# Low PIM Coaxial Cable Range N & 7/16

- Coaxial cable range R285 series
  - Interface: N & 7/16
  - Impedance: 50 Ohms
  - Frequency range:
    - N: 0-11 GHz
    - 7/16: 0-7.5 GHz
  - PIM<sub>3</sub>: -125 dBm (-168 dBc) @ 20 watts
- Additional information available in the Application guide (D1032DE)

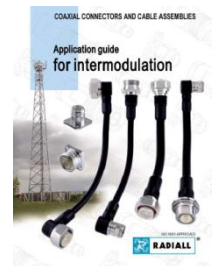

# Low PIM Coaxial Cable SMA

- Characteristics
  - Interface: SMA
  - Impedance: 50 Ohms
  - Frequency range:
    - 0-18 GHz
    - PIM<sub>3</sub>: -117 dBm (-160 dBc) @ 20 watts
- SHF 4.2mm and semi-rigid (.141) cables are not yet classified



A world map where the landmasses are filled with a dense pattern of small, light blue icons. These icons represent various concepts such as technology, communication, and business, including symbols for Wi-Fi, a globe, a smartphone, a laptop, a mail envelope, a gear, a lightbulb, a magnifying glass, a speech bubble, a bar chart, a pie chart, a network diagram, a person, a handshake, a document, a checkmark, a plus sign, a minus sign, a dollar sign, a percentage sign, a bar chart, a pie chart, a network diagram, a person, a handshake, a document, a checkmark, a plus sign, a minus sign, a dollar sign, and a percentage sign.

# Product Information

# Product information

- Based on high runners used in the test industry, below is a list of Radiall devices that will be introduced into the marketplace:
  - SPDT SMA DC-18GHz (*based on R570 series*)
  - SPDT N DC-12.4GHz (*based on R570 series too*)
  - SP4&6T SMA DC-18GHz (*based on R573 series*)
  - SP4&6T N DC-12.4GHz (*based on R573 series*)
  - DPDT SMA SMA DC-18GHz (*based on R577 series*)
  - DPDT N DC-12.4 GHz (*Based on R577 series*)



# Product Information

- The typical value for RADIALL RAMSES coaxial switches is approximately 120 dBc (with 2 carriers @ +43 dBm, i.e. 20 watts)
- Radiall offers outstanding PIM performance
  - -160 dBc @ +43 dBm

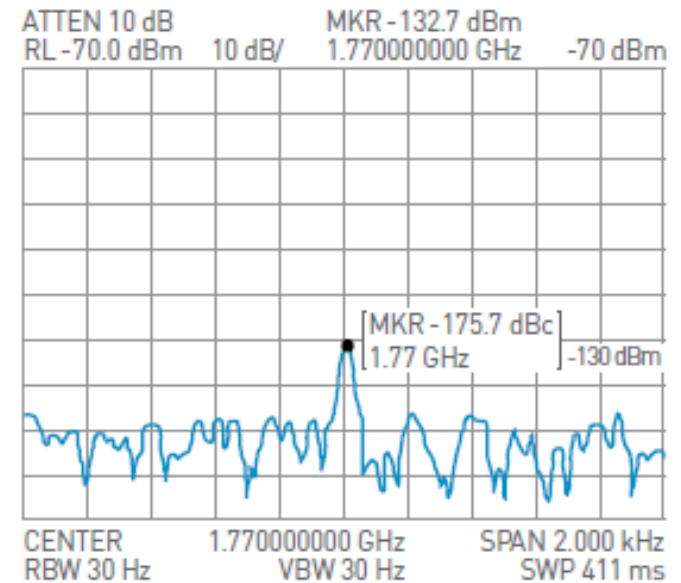

# Product Information

- Part number selection: (132 part numbers)
  - SPDT SMA DC -18 GHz
  - SPDT N D -12.4 GHz

**R 570 . . . . . LP**

**RF Connectors:**  
 1: N up to 12.4 GHz  
 4: SMA up to 18 GHz

**Type:**  
 0: Failsafe  
 1: Failsafe + I.C.  
 2: Latching  
 3: Latching + I.C.  
 5: Latching + S.C.O.(1)  
 6: Latching + S.C.O. + I.C.(1)

**Actuator Voltage:**  
 2: 12 Vdc  
 3: 28 Vdc

**Actuator Terminals:**  
 0: Solder pins  
 5: D-Sub connector (4)

**Options:**  
 0: Without option  
 1: Positive common (2)  
 3: With suppression diodes  
 4: With suppression diodes and positive common (2)

**TTL option:**  
 1: Without TTL driver  
 0: With TTL driver (1) (3)

**I.C.:** Indicator contact / S.C.O.: Self Cut-Off  
 (1): Suppression diodes are already included in the S.C.O. & TTL option.  
 (2): Positive common shall be specified with type 2,3,5 & 6 because failsafe models can be used with both polarities.  
 (3): Polarity is not relevant to application for switches with TTL driver.  
 (4): Only for N models.



# Product Information

- Part number selection: (160 part numbers)
  - SP6T SMA DC -18 GHz
  - SP6T N DC -12.4 GHz

**R 573 . . . . . LP**

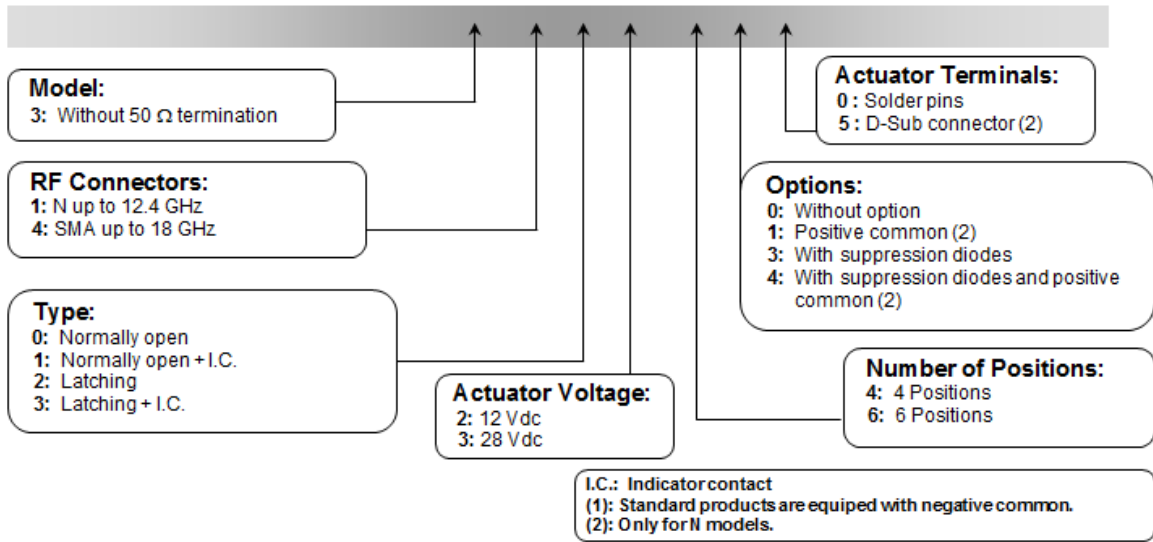



# Product Information

- Part number selection: (176 part numbers)
  - DPDT SMA DC -18 GHz
  - DPDT N DC -12.4 GHz

**R 577 . . . . . LP**

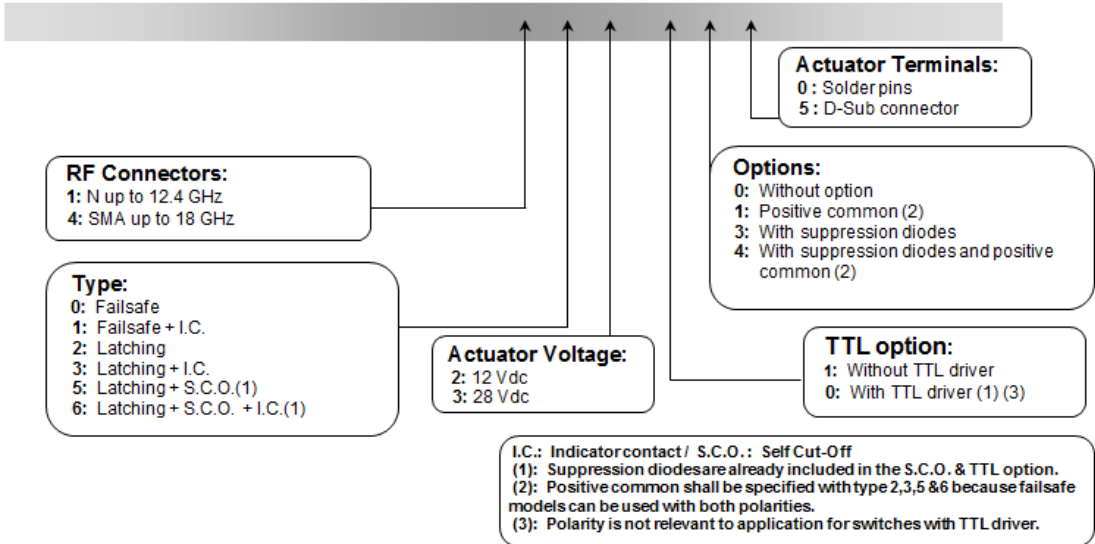

A world map where the landmasses are filled with a dense pattern of small, light blue icons. These icons include various symbols such as airplanes, buildings, gears, and abstract shapes, representing different industries and applications. The background is white, and the map is centered on the Atlantic Ocean.

# Applications

# Instrumentation

- Modular Instrumentation
  - VXI, PXI & LXI switching modules
- Instrumentation (various test benches)
  - ATE (Telecom Equipment Testing)
    - Cellular infrastructure site testing
    - Components and assembly shop test stations
    - Components and assembly shop test stations
  - Laboratory Test Benches
    - Qualification / certification
    - Environmental & Temperature test chambers

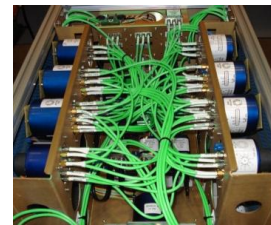



# Product Benefits

# Product Benefits

- Life span: 2 million cycles
- Performance: -160 dBc (PIM 3<sup>rd</sup> order frequency)
  - Only Dow-key products offer the same Low PIM level
  - Other competitors: -150 dBc max
- Additional Low PIM Radiall devices (various coaxial cables)
- Large offer (500 part numbers) because it's a RAMSES extension range
- Competitive price