

## SPnT Terminated & non Terminated up to 40 GHz

SMA – SMA 2.9 – QMA – DIN 1.6 / 5.6



Radiall's R573 & R574 multithrow coaxial switches are offered in many configurations (over 40,000 possible combinations) including Terminated and non Terminated options. Radiall offers reliable products, with shorter delivery times and competitive pricing. Excellent typical RF performance make RAMSES switches (40 GHz) ideal for Automated Test Equipment (ATE) and other measurement applications.

These switches are suitable for defense, industrial, instrumentation and telecommunication applications.

Example of P/N:

R574453605 is a terminated SP6T SMA up to 18 GHz, Latching, Self Cut-Off, 28 Vdc, Indicators and male 25 pin D-Sub connector.

### PART NUMBER SELECTION

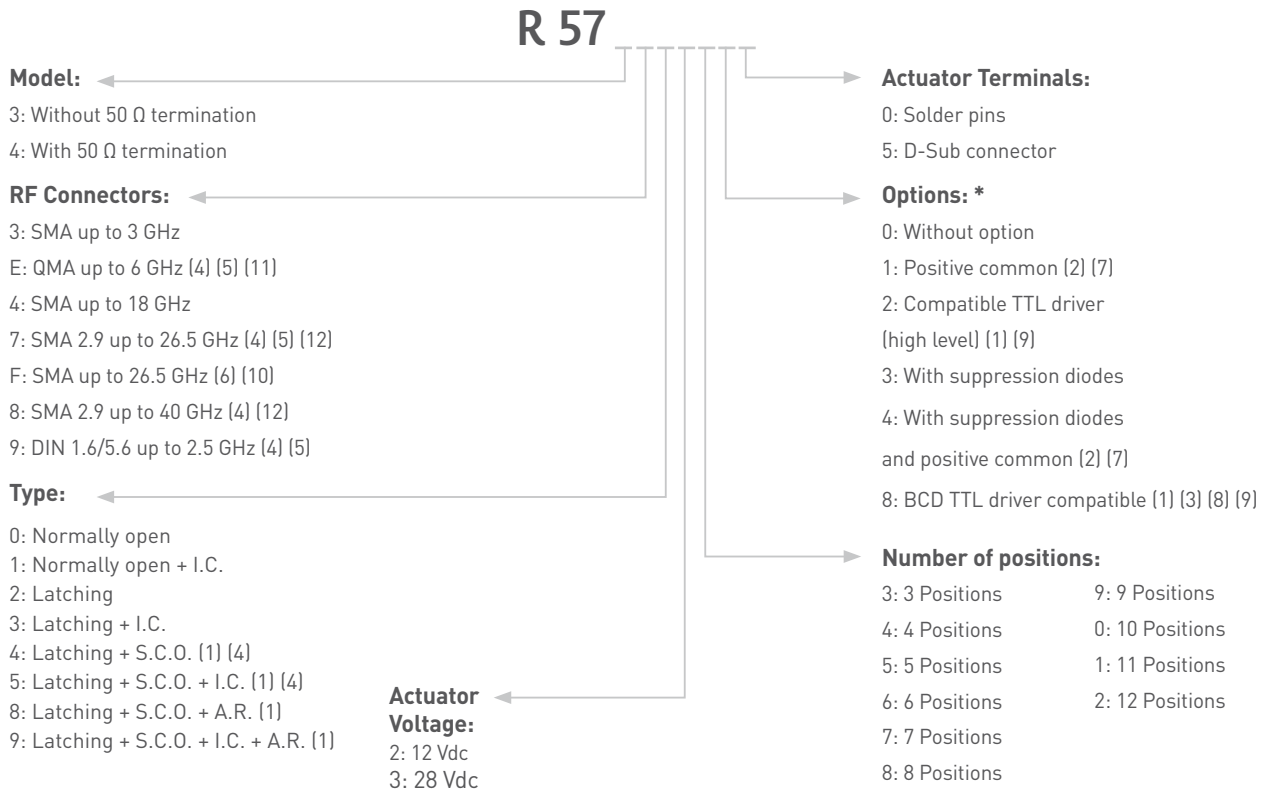

I.C.: Indicator contact / S.C.O. : Self Cut-Off / A.R. : Auto Reset

(1): These models are already equipped with suppression diodes

(2): Standard products are equipped with negative common

(3): Latching BCD driver enables also a global reset through driver code 0000 [see BCD logic coding page 1-11]

(4): Available only up to 6 positions

(5): Model "3" only

(6): Model "4" only up to 6 positions

(7): Option not available for type 4, 5, 8 and 9

(8): Option available only with type 0, 1, 8 and 9

(9): Polarity is not relevant to application for switches with TTL driver

(10): 8 and 10 positions are available only up to 22 GHz, 12 positions only up to 18 GHz



(11) : The QLF trademark (quick lock formula®) standard applies to QMA and QN series and guarantees the full intermateability between suppliers using this trademark. Using QLF certified connectors also guarantees the specified level of RF performance

(12) connector SMA 2.9 is equivalent to "K connector®", registered trademark of Anritsu

\*For precisions see availability of options chart page 5-9

## SPnT Terminated & non Terminated up to 40 GHz

SMA – SMA 2.9 – QMA - DIN 1.6 / 5.6

### GENERAL SPECIFICATIONS

#### Type 2, 3, 4 and 5:

Latching models have a RESET pin which commands the reset of all positions. This command should be used before switching from one position to another. If not, two positions will be set at the same time.

Note: During the RESET operation the global current is: the nominal operating current multiplied by the number of positions.

#### Type 8, 9:

Latching models with AUTOMATIC RESET are available; these products have an internal SET/RESET circuit which automatically resets all the non-selected positions and sets the desired position. This option simplifies the use of latching switches by suppressing the RESET command in switching sequence.

An electronic circuit supplies successively groups of 2, 3 or 4 actuators, in order to limit the maximum current.

The current with this option is the total current of 2, 3 or 4 reset coils in the same time (see table below).

Example: During the AUTOMATIC RESET operation, at 28 Vdc, 4 position switch has a temporary consumption of only 250 mA, during 40 ms maximum.

### SWITCHING SEQUENCE

#### For SP6 to 8T

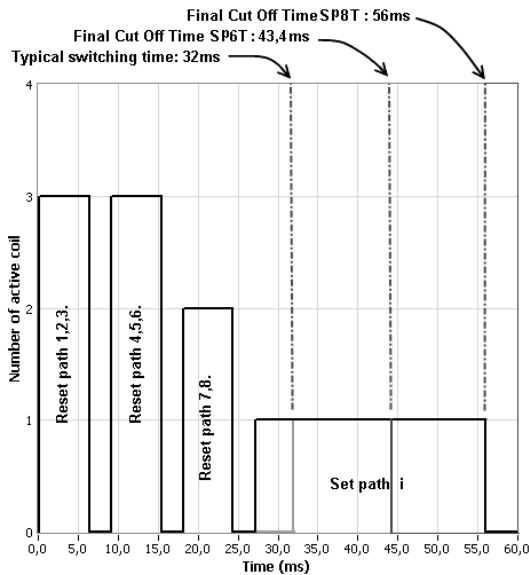

#### For SP9 to 12T

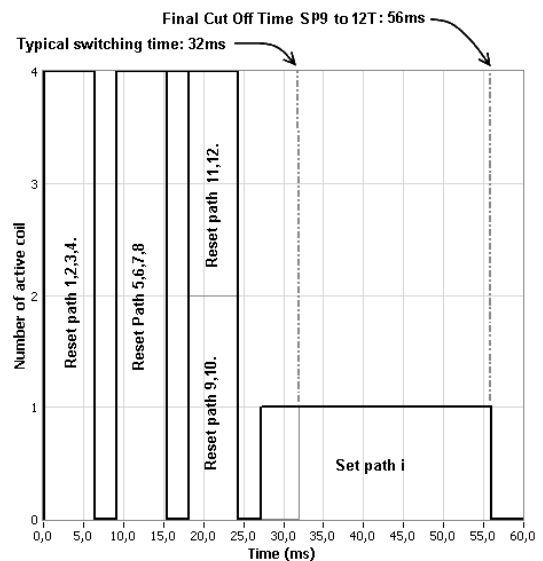

n = number of positions

Operating Total Current At 23 ° C (mA) SPnT Latching				
Number of positions	12 Volts		28 Volts	
	Manual Reset	Automatic Reset	Manual Reset	Automatic Reset
3 to 4	320 x n	640	125 x n	250
5 to 8	320 x n	960	125 x n	375
9 to 12	320 x n	1280	125 x n	500

Availability of options according to both type and number of positions

Type	Numbers of positions	Available options
0 or 1	3 to 12	0 - 1 - 2 - 3 - 4 - 8
2 or 3	3 to 6	0 - 1 - 2 - 3 - 4
	7 to 12	0 - 1 - 3 - 4
4 or 5	3 to 6	0 - 2
	7 to 12	Not available
8 or 9	3 to 12	0 - 2 - 8

**SPnT Terminated & non Terminated up to 40 GHz**

**SMA – SMA 2.9 – QMA - DIN 1.6 / 5.6  
GENERAL SPECIFICATIONS**

Operating mode		Normally open		Latching	
Nominal operating voltage	Vdc	12 (10.2 / 13)	28 (24 / 30)	12 (10.2 / 13)	28 (24 / 30)
Coil resistance (+/-10%)	Ω	47.5	275	See table on previous page	
Nominal operating current at 23°C	mA	250	102		
Average power		See Power Rating Chart page <b>1-13</b>			
TTL input	High Level	2.2 to 5.5 V (TTL Option) / 800µA max 5.5 volts 3.5 to 5.5 V (BCD Option)			
	Low Level	0 to 0.8 V (TTL Option) / 20µA max 0.8 volts 0 to 1.5 V (BCD Option)			
Indicator rating		1 Watt / 30 Volts / 100 mA			
Switching time (Max)	ms	15 ms For automatic reset models: SP3T to SP6T => 40 ms SP7T to SP12T => 50 ms			
Life (Min)	Non terminated SP3 to 6T (R573 serie)	SMA - QMA 5 million cycles		SMA 2.9 - 1.6/5.6 2 million cycles	
	Terminated SP3 to 6T (R574 serie)	2 million cycles			
	SP7 to 12T (all models)				
Connectors		SMA - SMA2.9 - QMA - DIN 1.6/5.6			
Actuator terminals		Solder pins or male 25 pin D-sub connector			
Operating temperature range	DIN 1.6/5.6	-25°C to +70°C			
	SMA - SMA 2.9 - QMA	-40°C to +85°C			
Storage temperature range	DIN 1.6/5.6	-40°C to +85°C			
	SMA - SMA 2.9 - QMA	-55°C to +85°C			
Vibration (MIL STD 202, method 204D, cond.D)		10-2000 Hz , 20g operating for SP3 to 8T, survival for SP7 to 12T			
Shock (MIL STD 202, method 213B, cond.C)		100g / 6 ms, 1/2 sine operating for SP3 to 8T, survival for SP7 to 12T			

**RF PERFORMANCES**

SMA Connector						
Number of positions	Frequency Range GHz	V.S.W.R. (max)	Insertion Loss (max) dB	Isolation (min) dB	Impedance Ω	
3 to 6	DC - 3 DC - 18 DC - 26.5	DC - 3	1.20	0.20	80	50
		3-8	1.30	0.30	70	
		8 - 12.4	1.40	0.40	60	
		12.4 - 18	1.50	0.50	60	
		18 - 26.5	1.70	0.70	50	
7 to 8	DC - 3 DC - 22	DC - 3	1.20	0.20	80	
		3 - 8	1.30	0.30	70	
		8 - 12.4	1.40	0.40	60	
		12.4 - 16	1.50	0.55	60	
		16 - 18	1.60	0.60	60	
9 to 10	DC - 3 DC - 22	18 - 22	1.70	0.70	60	
		DC - 3	1.20	0.20	80	
		3 - 8	1.30	0.30	70	
		8 - 12.4	1.40	0.40	60	
		12.4 - 15.5	1.50	0.50	60	
11 to 12	DC - 3 DC - 18	15.5 - 18	1.70	0.70	55	
		18 - 22	1.80	0.80	55	
		DC - 3	1.20	0.20	80	
		3 - 8	1.40	0.40	70	
		8 - 12.4	1.60	0.60	60	
		12.4 - 15	1.70	0.70	60	
		15 - 18	1.80	0.80	50	

**SPnT Terminated & non Terminated up to 40 GHz**

SMA – SMA 2.9 – QMA – DIN 1.6 / 5.6

**RF PERFORMANCES**

SMA2.9 Connector						
Number of positions	Frequency Range GHz		V.S.W.R. (max)	Insertion Loss (max) dB	Isolation (min) dB	Impedance Ω
3 to 6	DC - 26.5 DC - 40	DC - 6	1.30	0.20	70	50
		6 - 12.4	1.40	0.40	60	
		12.4 - 18	1.50	0.50	60	
		18 - 26.5	1.70	0.70	55	
		26.5 - 40	2.20	1.10	50	

1.6/5.6 Connector						
Number of positions	Frequency Range GHz		V.S.W.R. (max)	Insertion Loss (max) dB	Isolation (min) dB	Impedance Ω
3 to 6	DC - 2.5	DC - 1	1.30	0.20	80	75
		1 - 2.5	1.40	0.30	70	

QMA Connector						
Number of positions	Frequency Range GHz		V.S.W.R. (max)	Insertion Loss (max) dB	Isolation (min) dB	Impedance Ω
3 to 6	DC - 6	DC - 3	1.20	0.20	80	50
		3 - 6	1.30	0.30	70	

See page 5-12, 5-13, 5-14 and 5-15 for typical RF performances

**R573 AND R574 TYPICAL RF PERFORMANCES**

Example: SP6T QMA up to 6 GHz

**Insertion Loss and Isolation**

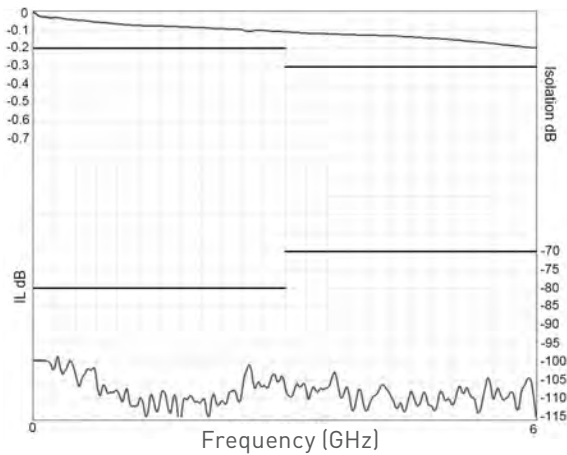

**V.S.W.R.**

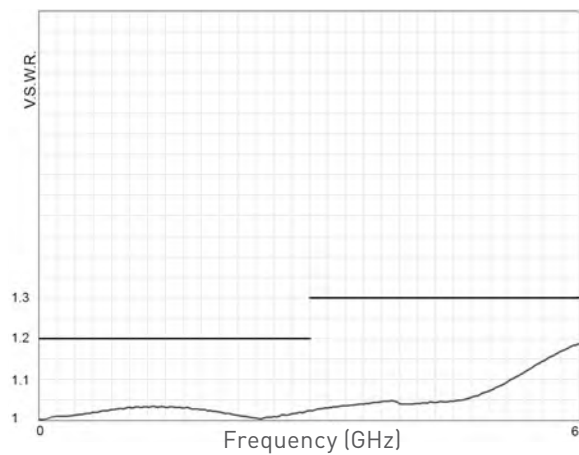

## SPnT Terminated & non Terminated up to 40 GHz

SMA - SMA 2.9 - QMA - DIN 1.6 / 5.6

Example: Non terminated SP6T SMA up to 18 GHz

### Insertion Loss and Isolation

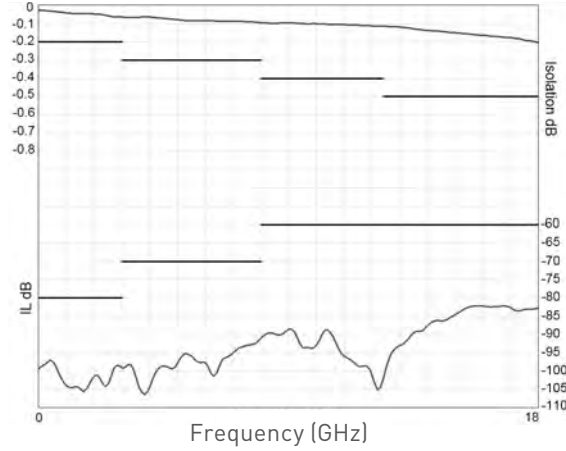

### V.S.W.R.

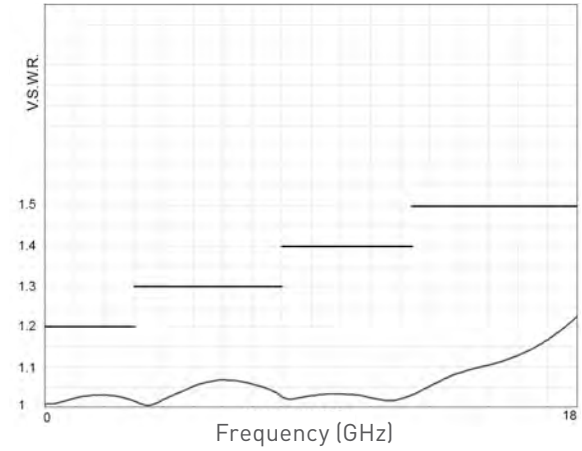

Example: Non terminated SP6T SMA 2.9 up to 26.5 GHz

### Insertion Loss and Isolation

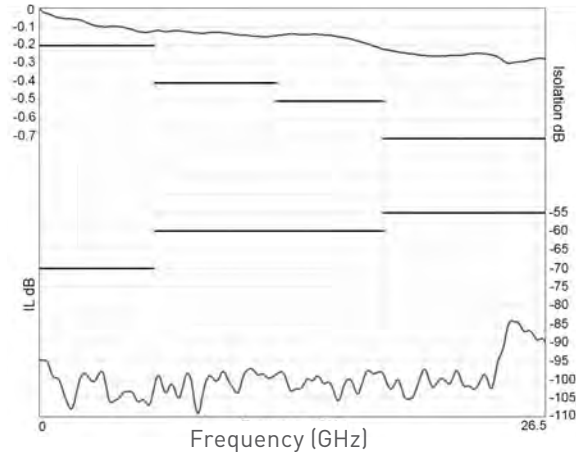

### V.S.W.R.

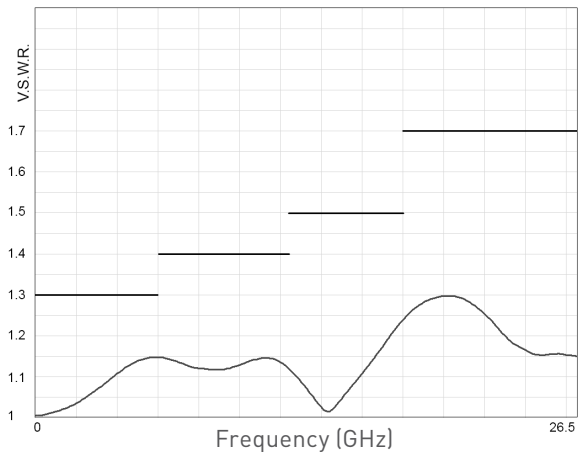

Example: Non terminated SP6T SMA 2.9 up to 40 GHz

### Insertion Loss and Isolation

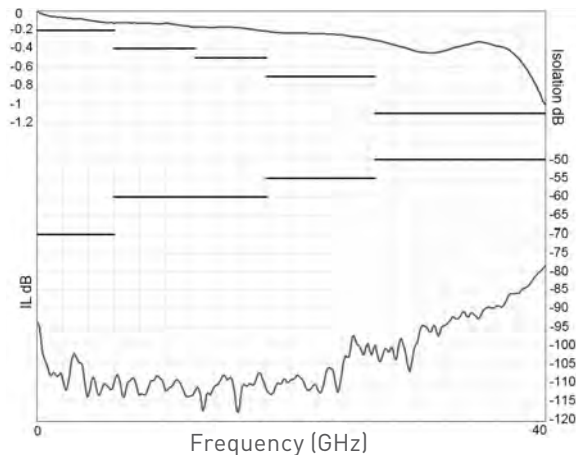

### V.S.W.R.

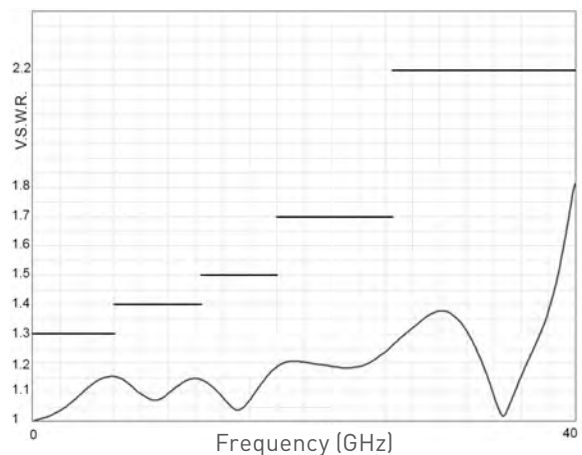

### SPnT Terminated & non Terminated up to 40 GHz

SMA – SMA 2.9 – QMA – DIN 1.6 / 5.6

Example: Terminated SP6T SMA up to 18 GHz

#### Insertion Loss and Isolation

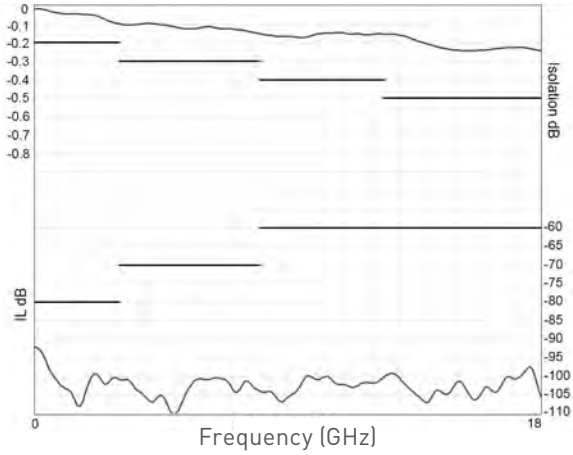

#### V.S.W.R.

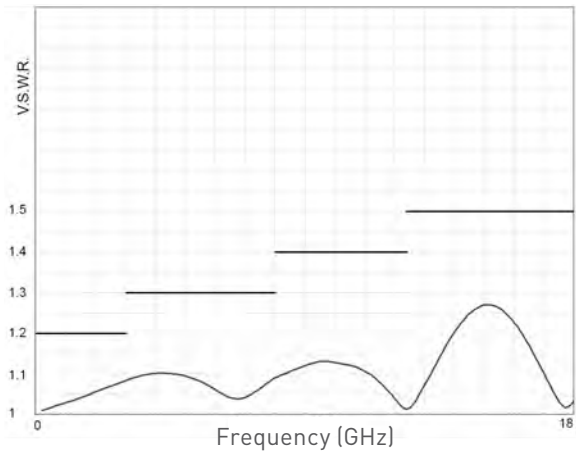

Example: Terminated SP6T SMA up to 26.5 GHz

#### Insertion Loss and Isolation

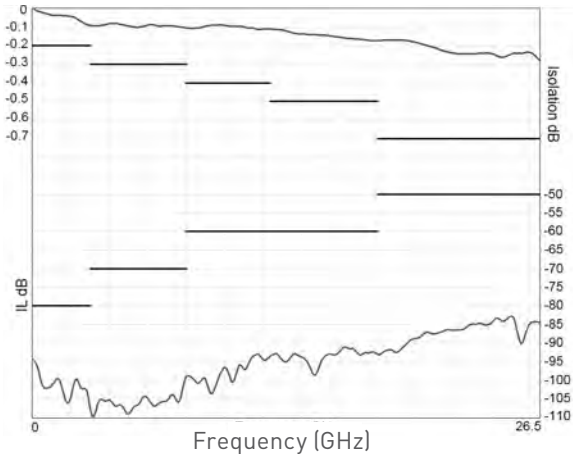

#### V.S.W.R.

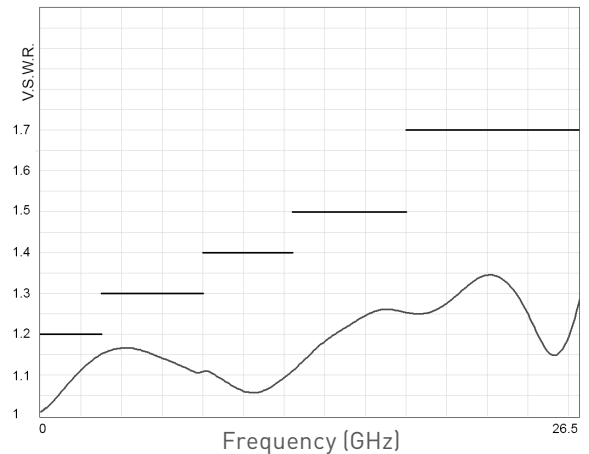

Example: Terminated SP6T SMA 2.9 up to 40 GHz

#### Insertion Loss and Isolation

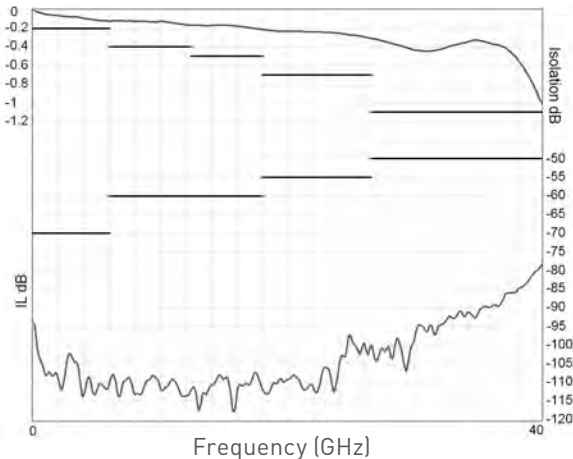

#### V.S.W.R.

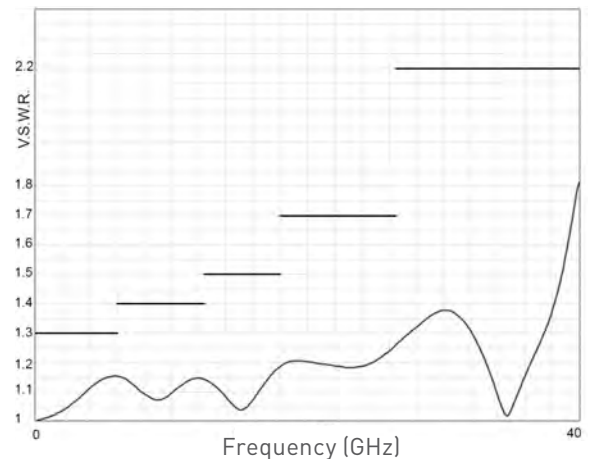

### SPnT Terminated & non Terminated up to 40 GHz

SMA - SMA 2.9 - QMA - DIN 1.6 / 5.6

Example: Non terminated SP6T 1.6/5.6 up to 2.5 GHz

Insertion Loss and Isolation

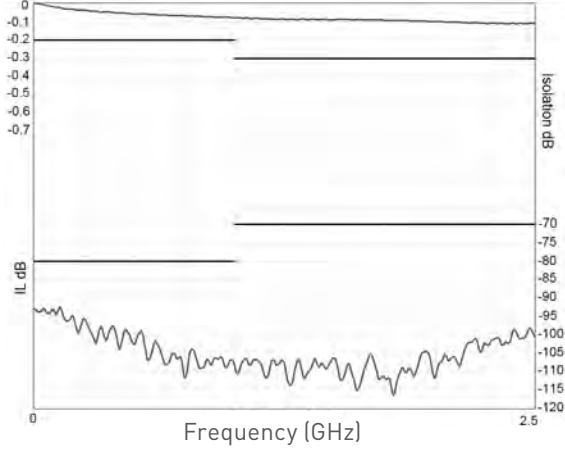

V.S.W.R.

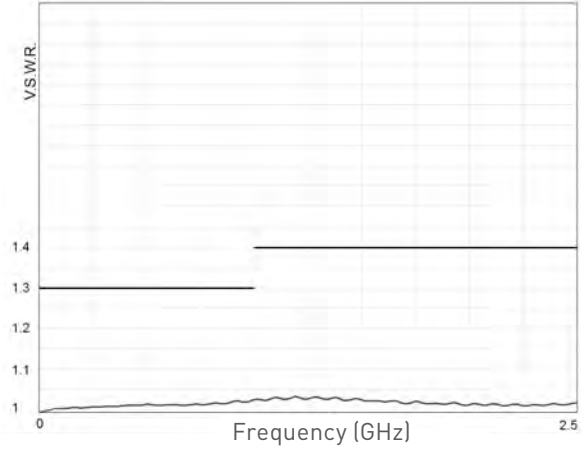

Example: SP8T SMA up to 22 GHz

Insertion Loss and Isolation

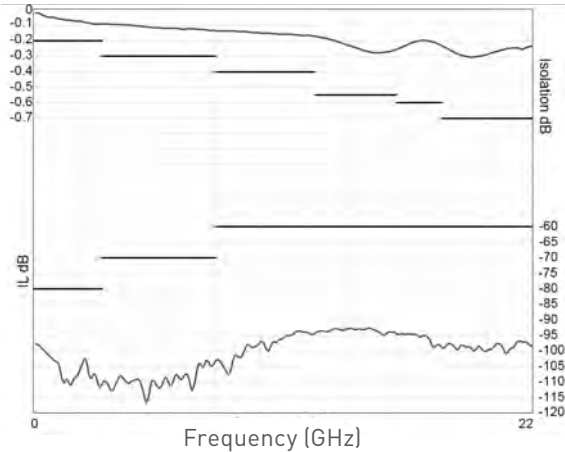

V.S.W.R.

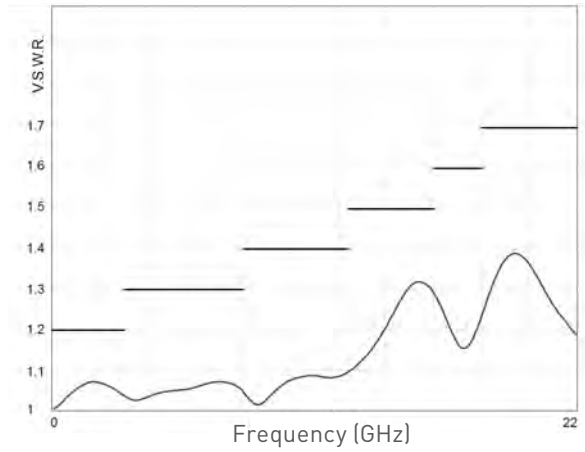

Example: SP10T SMA up to 22 GHz

Insertion Loss and Isolation

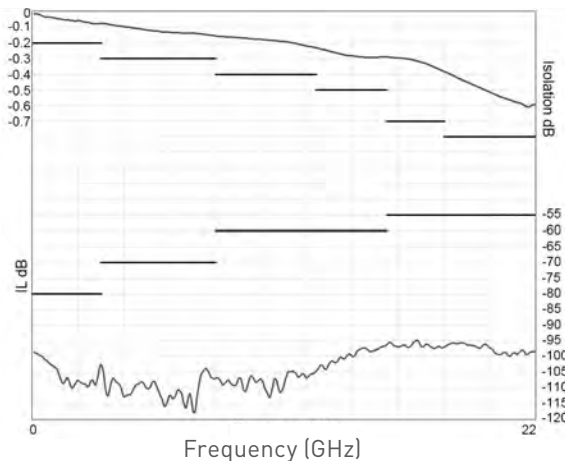

V.S.W.R.

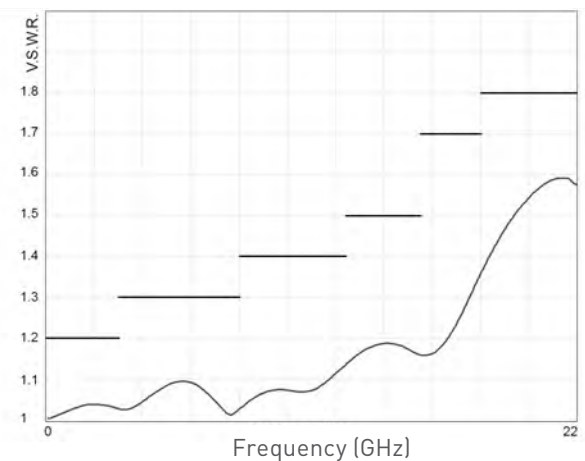

**SPnT Terminated & non Terminated up to 40 GHz**

SMA – SMA 2.9 – QMA – DIN 1.6 / 5.6

Example: SP12T SMA up to 18 GHz

**Insertion Loss and Isolation**

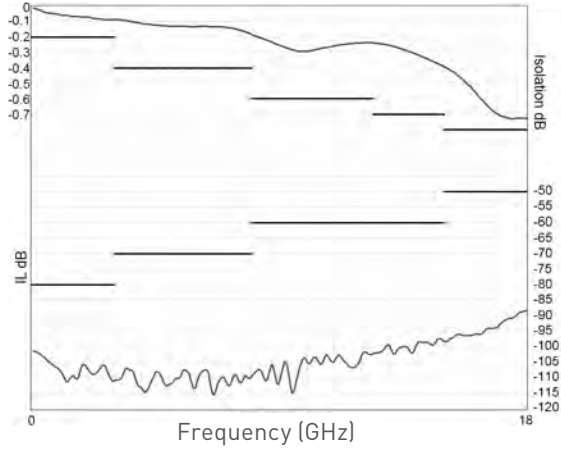

**V.S.W.R.**

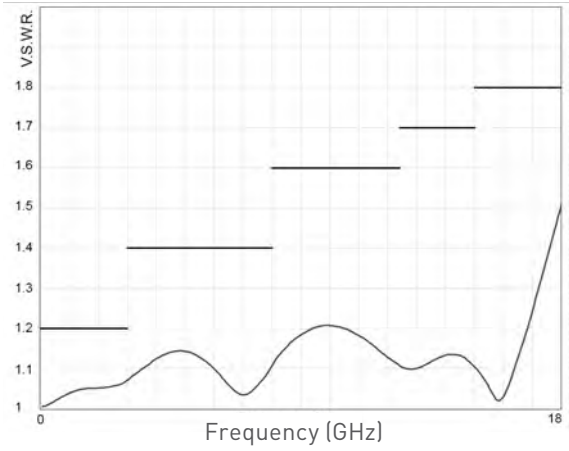

**TYPICAL OUTLINE DRAWINGS**

NON TERMINATED 3 to 6 positions

Connectors	A max (mm)
SMA up to 26.5 GHz	7.4
SMA2.9 up to 40 GHz	6.3
QMA up to 6 GHz	10.8
DIN 1.6/5.6 up to 2.5 GHz	11.5

Solder pins	Type 0 or 1 with option 0 - 1 - 3 or 4
	Type 2 or 3 with option 0 or 1

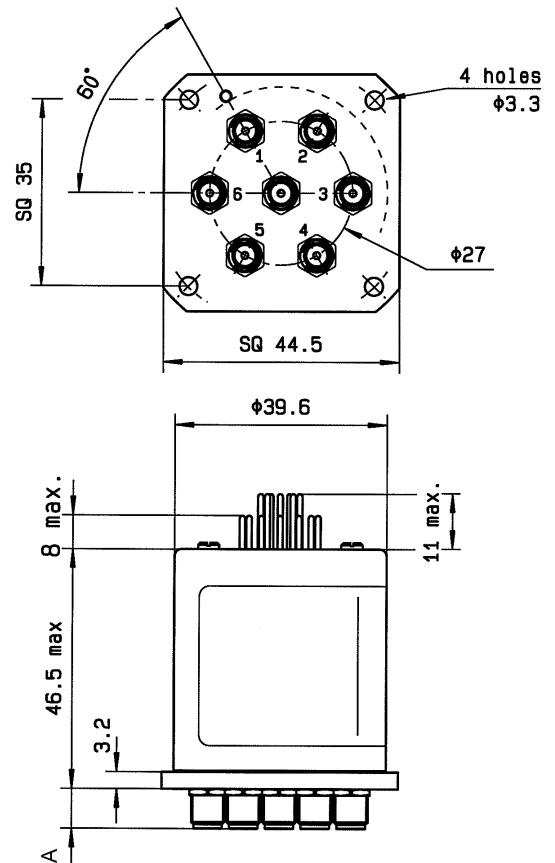

RAMSES SERIES



## SPnT Terminated & non Terminated up to 40 GHz

SMA – SMA 2.9 – QMA – DIN 1.6 / 5.6

### TYPICAL OUTLINE DRAWINGS

NON TERMINATED 3 to 6 positions (continued)

Solder pin model

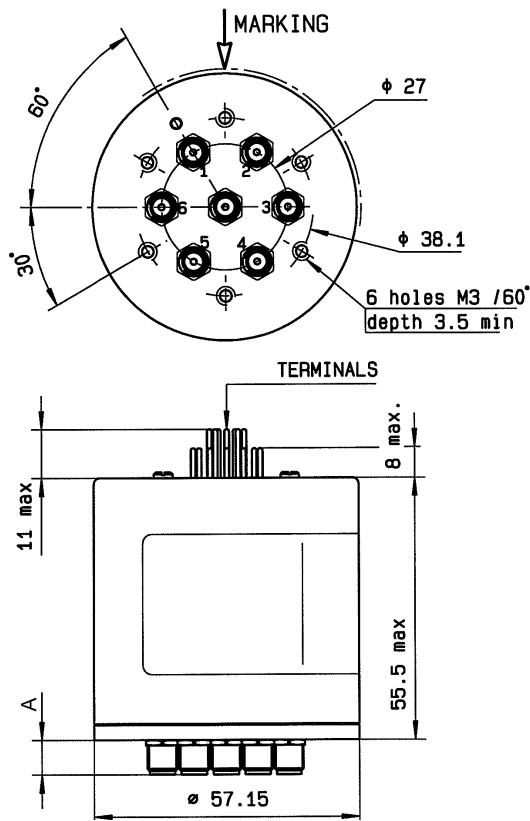

D-sub model

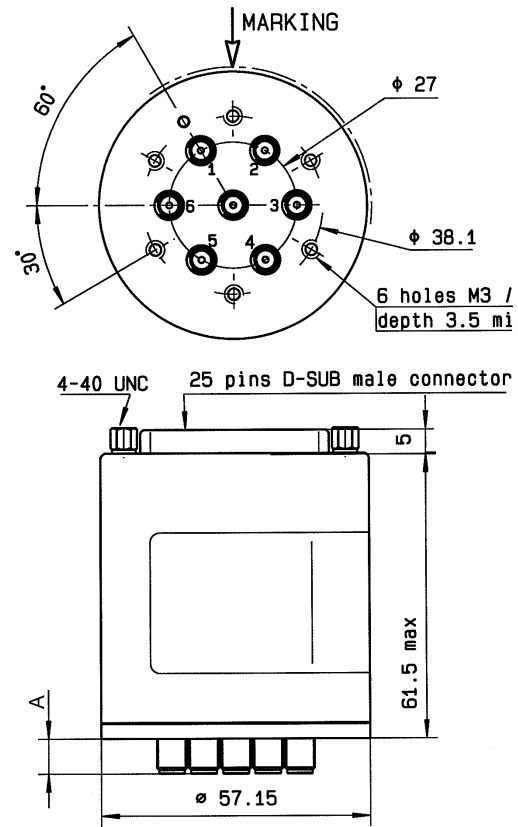

Solder pins	Type 0 or 1 with option 2 or 8
	Type 2 or 3 with option 2 - 3 - 4 or 8
	Type 4 - 5 - 8 or 9 with option 0 - 2 or 8

D-Sub connector	All models
-----------------	------------

Connectors	A max (mm)
SMA up to 26.5 GHz	7.4
SMA 2.9 up to 40 GHz	6.3
QMA up to 6 GHz	10.8
DIN 1.6/5.6 up to 2.5 GHz	11.5

**SPnT Terminated & non Terminated up to 40 GHz**

SMA – SMA 2.9 – QMA – DIN 1.6 / 5.6

**TYPICAL OUTLINE DRAWINGS**

TERMINATED 3 to 6 positions

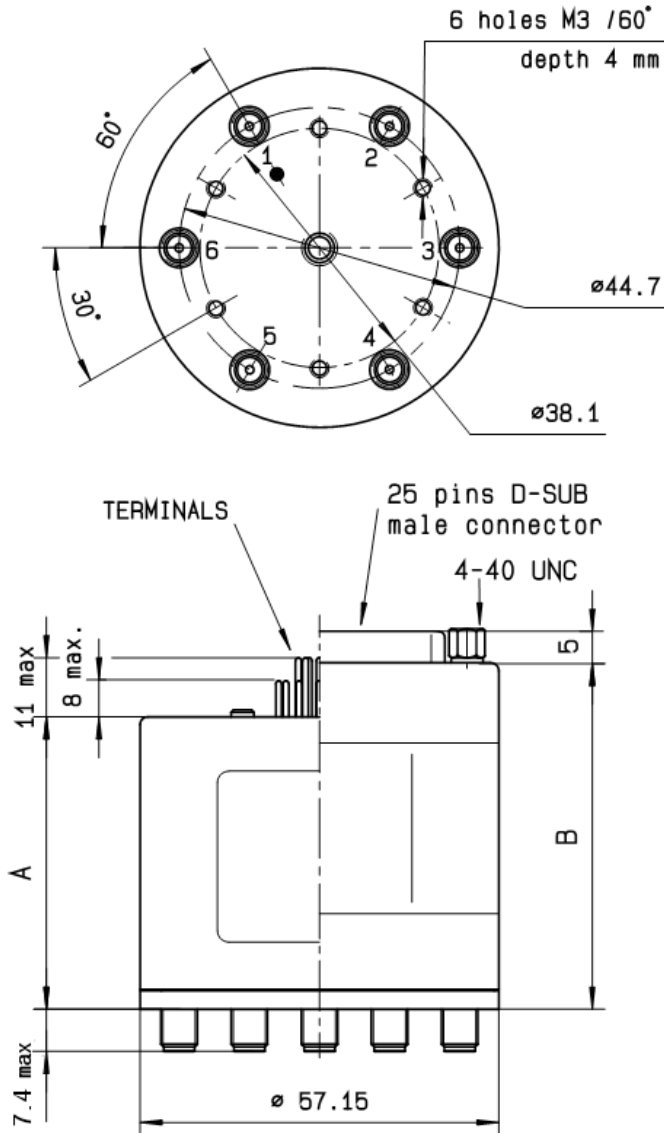

	A	B
	Solder Pins	D-Sub Connector
Type 0 - 1 - 2 or 3 with option 0 - 1 - 3 or 4	46.5	61.5
Type 0 - 1 - 2 or 3 with option 2 or 8	55.5	61.5
Type 4 - 5 - 8 or 9 with option 0 - 1 - 2 or 8	55.5	61.5

**SPnT Terminated & non Terminated up to 40 GHz**

SMA – SMA 2.9 – QMA - DIN 1.6 / 5.6

**TYPICAL OUTLINE DRAWINGS**

TERMINATED 3 to 6 positions 26.5 GHz & 40 GHz

26.5 GHz model

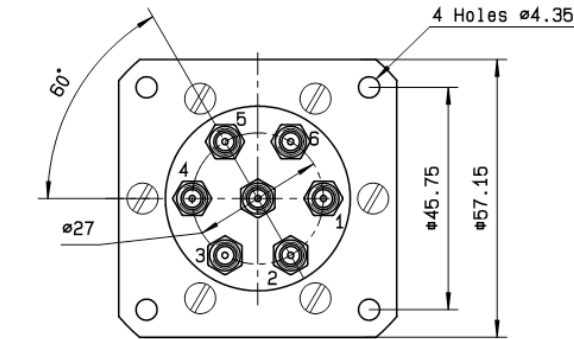

40 GHz model

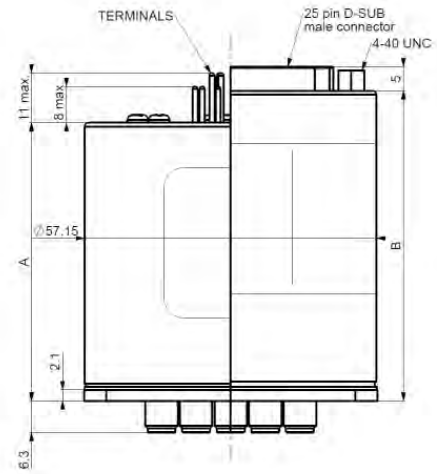
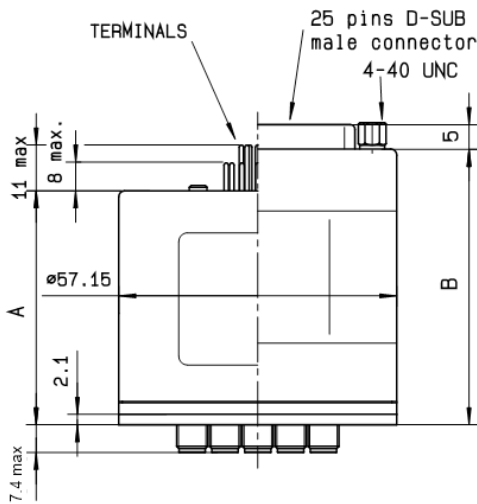
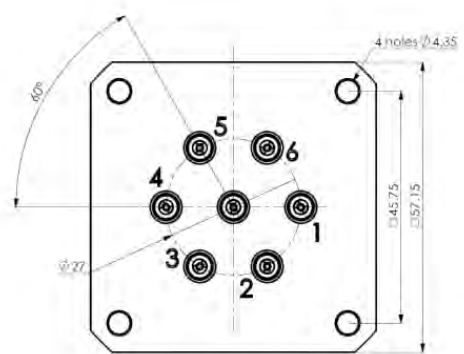

	A	B
	Solder Pins	D-Sub Connector
Type 0 - 1 - 2 or 3 with option 0 - 1 - 3 or 4	48.5	63.5
Type 0 - 1 - 2 or 3 with option 2 or 8	57.5	63.5
Type 4 - 5 - 8 or 9 with option 0 - 1 - 2 or 8	57.5	63.5

## SPnT Terminated & non Terminated up to 40 GHz

SMA – SMA 2.9 – QMA – DIN 1.6 / 5.6

### TYPICAL OUTLINE DRAWINGS

TERMINATED or NON TERMINATED 7 to 12 positions

Type	A (max) mm	
	Solder Pins	D-Sub connector
Type 0 - 1 - 2 or 3 with option 0 - 1 - 3 or 4	50	66
Type 0 - 1 - 2 or 3 with option 2 or 8 and Type 4 - 5 - 8 or 9 with option 0 - 1 - 2 or 8	61	66

Number of positions	B diameter	C diameter	D diameter	E
7 - 8	49.8	44.7	56.9	4 holes M3 depth 4mm
9 - 10	30.5	44.7	63.5	
11 - 12	40.6	55.9	68.3	

10 position model

Terminated up to 18 GHz with solder pins

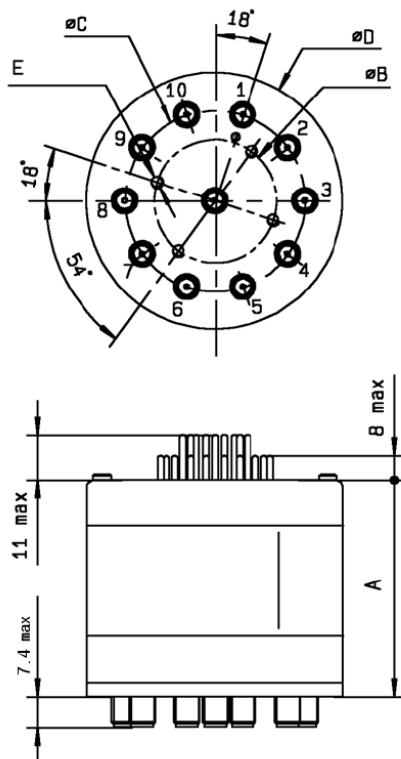

12 position model

Terminated up to 12.4 GHz with D-Sub

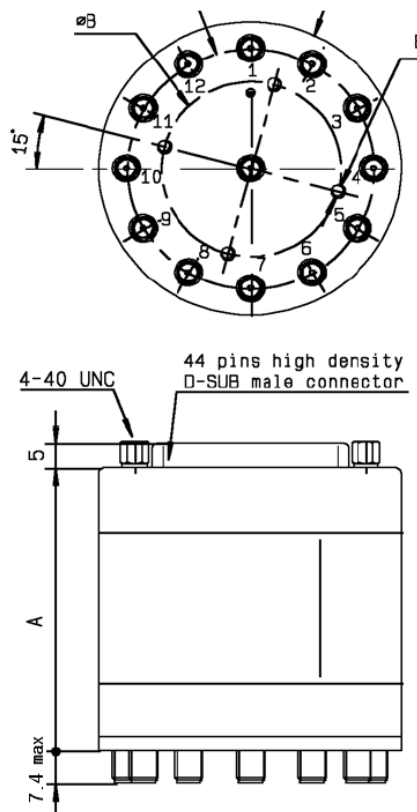

## SPnT up to 12.4 GHz - RAMSES Concept

### N - BNC - TNC



Radiall's R573 & R574 multithrow coaxial switches are offered in many configurations (over 40,000 possible combinations) including Terminated and non Terminated options. Radiall offers reliable products, with shorter delivery times and competitive pricing. Excellent typical RF performance make RAMSES switches (12.4 GHz) ideal for Automated Test Equipment (ATE) and other measurement applications.

These switches are suitable for defense, industrial, and telecommunication applications.

Example of P/N:

R573103600 is a SP6T N up to 12.4 GHz, Normally Open, 28 Vdc, and solder pins.

### PART NUMBER SELECTION

**R 57**

**Model:**

- 3: Without 50 Ω termination
- 4: With 50 Ω termination

**RF Connectors:**

- 0: N up to 3 GHz
- 1: N up to 12.4 GHz (9)
- 2: BNC up to 3 GHz (4) (5)
- 5: TNC up to 3 GHz (4) (5)
- 6: TNC up to 12.4 GHz (4) (5)

**Type:**

- 0: Normally open
- 1: Normally open + I.C.
- 2: Latching
- 3: Latching + I.C.
- 4: Latching + S.C.O. (1) (4)
- 5: Latching + S.C.O. + I.C. (1) (4)
- 8: Latching + S.C.O. + A.R. (1)
- 9: Latching + S.C.O. + I.C. + A.R. (1)

**Actuator Voltage:**

- 2: 12 Vdc
- 3: 28 Vdc

**Actuator Terminals:**

- 0: Solder pins
- 5: D-Sub connector

**Options:\***

- 0: Without option
- 1: Positive common (2) (6)
- 2: Compatible TTL driver (1) (8)
- 3: With suppression diodes
- 4: With suppression diodes and positive common (2) (6)
- 8: BCD TTL driver compatible (1) (3) (7) (8)

**Number of positions:**

- 3: 3 Positions
- 4: 4 Positions
- 5: 5 Positions
- 6: 6 Positions
- 7: 7 Positions
- 8: 8 Positions
- 9: 9 Positions
- 0: 10 Positions
- 1: 11 Positions
- 2: 12 Positions

I.C.: Indicator contact / S.C.O.: Self Cut-Off / A.R.: Auto Reset

(1): These models are already equipped with suppression diodes

(2): Standard products are equipped with negative common

(3): Latching BCD driver enables also a global reset through driver code 0000

(see BCD logic coding page 1-13)

(4): Available only up 6 positions

(5): Model "3" only

(6): Option not available for type 4, 5, 8 and 9

(7): Option available only with type 0, 1, 8 and 9

(8): Polarity is not relevant to application for switches with TTL driver

(9) 7 to 12 positions are available only up to 8 GHz

\*For precisions see availability of options chart page 5-21

## SPnT up to 12.4 GHz - RAMSES Concept

N - BNC - TNC

### GENERAL SPECIFICATIONS

#### Type 2, 3, 4 and 5:

Latching models have a RESET pin which commands the reset of all positions. This command should be used before switching from one position to another. If not, two positions will be set at the same time.

Note: During the RESET operation the global current the nominal operating current multiplied by the number of positions.

#### Type 8, 9:

Latching models with AUTOMATIC RESET are available; these products have an internal SET/RESET circuit which automatically resets all the non-selected positions and sets the desired position. This option simplifies the use of latching switches by suppressing the RESET command in switching sequence.

An electronic circuit supplies successively groups of 2, 3 or 4 actuators, in order to limit the maximum current.

The current with this option is the total current of 2, 3 or 4 reset coils in the same time (see table below).

Example: During the AUTOMATIC RESET operation, at 28 Vdc, 4 position switch has a temporary consumption of only 250 mA, during 40 ms maximum.

### SWITCHING SEQUENCE

For SP6 to 8T

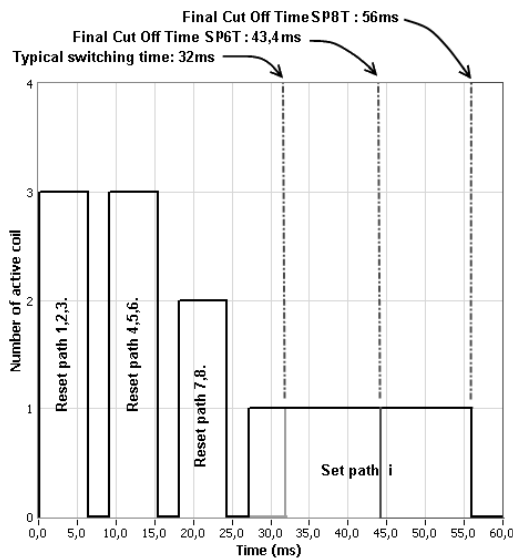

For SP9 to 12T

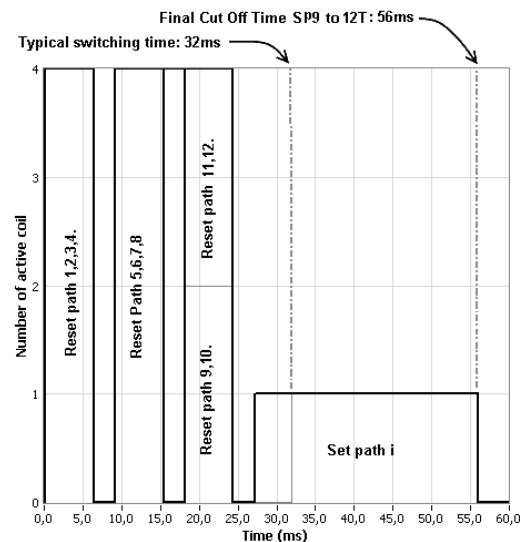

n = number of positions

Operating Total Current At 23 °C (mA) SPnT Latching				
Number of positions	12 Volts		28 Volts	
	Manual reset	Automatic reset	Manual reset	Automatic reset
3 to 4	320 x n	640	125 x n	250
5 to 8	320 x n	960	125 x n	375
9 to 12	320 x n	1280	125 x n	500

Availability of options according to both type and number of positions

Type	Numbers of positions	Available options
0 or 1	3 to 12	0 - 1 - 2 - 3 - 4 - 8
2 or 3	3 to 6	0 - 1 - 2 - 3 - 4
	7 to 12	0 - 1 - 3 - 4
4 or 5	3 to 6	0 - 2
	7 to 12	Not available
8 or 9	3 to 12	0 - 2 - 8

## SPnT up to 12.4 GHz - RAMSES Concept

N - BNC - TNC

### GENERAL SPECIFICATIONS

Operating mode		Normally open		Latching	
Nominal operating voltage (across operating temperature)	Vdc	12 (10.2 / 13)	28 (24 / 30)	12 (10.2 / 13)	28 (24 / 30)
Coil resistance (+/-10%)	Ω	47.5	275	See table on previous page	
Nominal operating current at 23°C	mA	250	102		
Average power		See Power Rating Chart page <b>1-13</b>			
TTL input	High Level	2.2 to 5.5 V (TTL Option) / 3.5 to 5.5 V (BCD Option)		800µA max 5.5 volts	
	Low Level	0 to 0.8 V (TTL Option) / 0 to 1.5 V (BCD Option)		20µA max 0.8 volts	
Indicator rating		1 Watt / 30 Volts / 100 mA			
Switching time (Max)		ms		15 ms For automatic reset models: SP3T to SP6T => 40 ms SP7T to SP12T => 50 ms	
Life (Min)	Non terminated SP3 to 6T (R573 serie)		2 million cycles		
	Terminated SP3 to 6T (R574 serie)				
	SP7 to 12T (all models)				
Connectors		N - TNC - BNC			
Actuator terminals		Solder pins or male 25 pin D-Sub connector			
Operating temperature range		-40°C to +85°C			
Storage temperature range		-55°C to +85°C			
Vibration (MIL STD 202, method 204D, cond.C)		10-2000 Hz , 10g		operating	
Shock (MIL STD 202, method 213B, cond.C)		50g / 1 ms, 1/2 sine		operating	

### RF PERFORMANCES

N - TNC - BNC Connector						
Number of positions	Frequency range GHz	V.S.W.R. (max)	Insertion loss (max) dB	Isolation (min) dB	Impedance Ω	
3 to 6	DC - 12.4	DC - 3	1.20	0.20	80	50
		3 - 8	1.35	0.35	70	
		8 - 12.4	1.50	0.50	60	
7 to 10	DC - 8	DC - 3	1.30	0.30	80	
		3 - 8	1.50	0.50	70	
11 to 12	DC - 8	DC - 3	1.35	0.50	70	
		3 - 8	1.70	1.00	60	

See page 5-25 for typical RF performances

### SPnT up to 12.4 GHz - RAMSES Concept

N - BNC - TNC

### R573 AND R574 TYPICAL RF PERFORMANCES

Example: SP6T N up to 12.4 GHz

#### Insertion Loss and Isolation

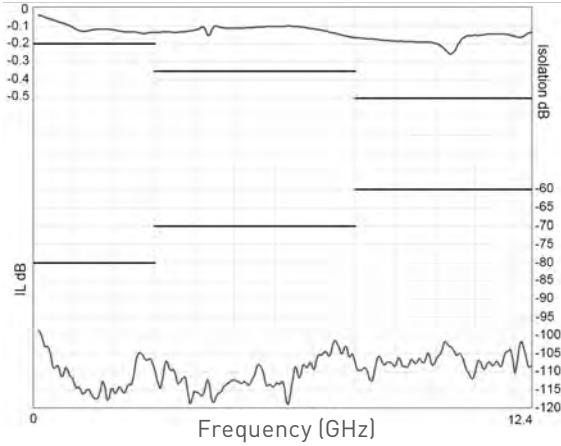

#### V.S.W.R.

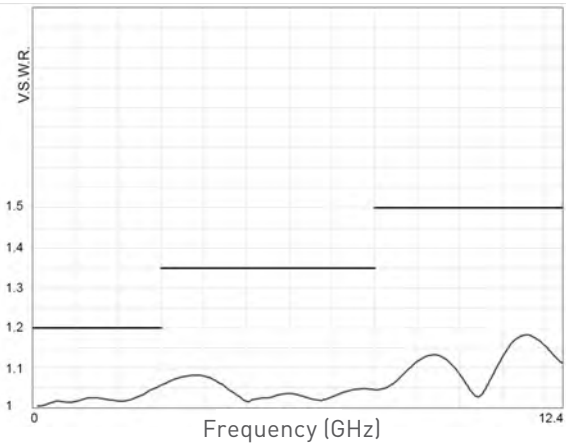

Example: SP6T TNC up to 12.4 GHz

#### Insertion Loss and Isolation

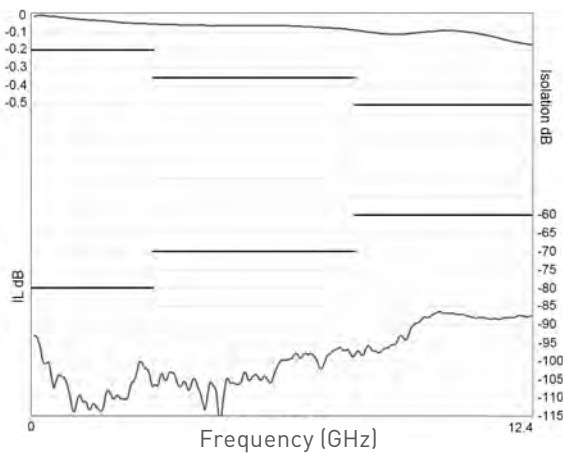

#### V.S.W.R.

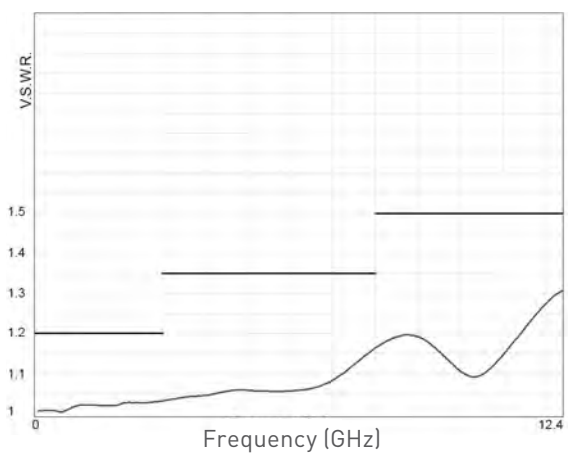

Example: SP8T up to 8 GHz

#### Insertion Loss and Isolation

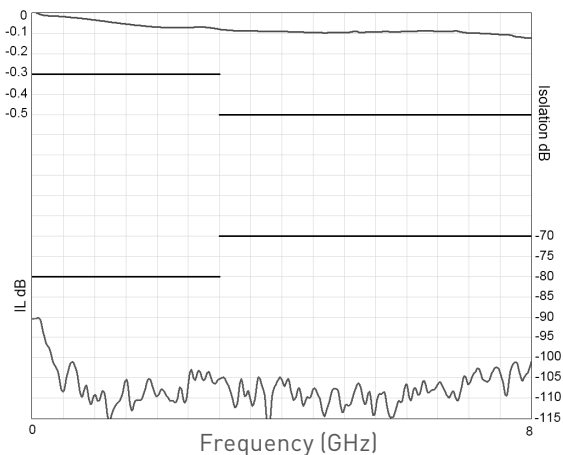

#### V.S.W.R.

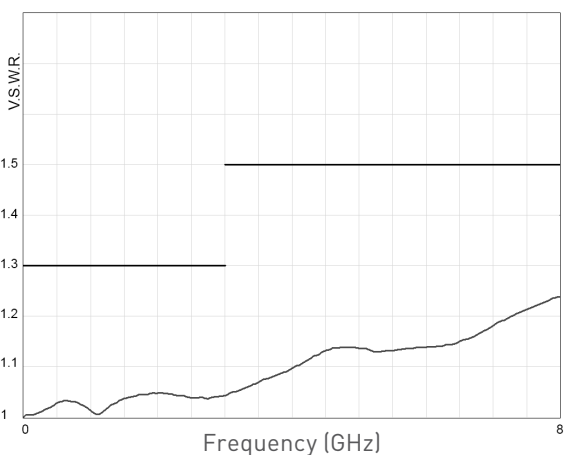



## SPnT up to 12.4 GHz - RAMSES Concept

N - BNC - TNC

### TYPICAL OUTLINE DRAWINGS

TERMINATED or NOT 3 to 12 positions

Type	A max (mm)	
	Solder Pins	D-Sub Connector
Type 0 - 1 - 2 or 3 with option 0 - 1 - 3 or 4	56	66
Type 0 - 1 - 2 or 3 with option 2 or 8 and Type 4 - 5 - 8 or 9 with option 0 - 1 - 2 or 8	71	71

Connectors	F max (mm)
N	18.8
BNC	11
TNC	11

Number of positions	B diameter	C diameter	D diameter	E
3 - 6	54	44.7	63.5	6 holes M4/60°
7 - 8	67.7	58.9	76.2	4 holes M4/90°
9 - 10	88.9	76.2	101.6	5 holes M4/72°
11 - 12	67.7	101.6	127	6 holes M4/60°

Model SP8T positions up to 8 GHz  
with solder pins

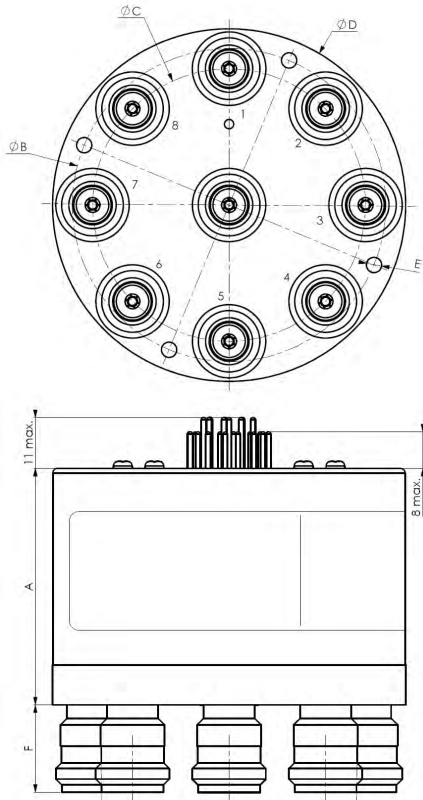

Model SP10T positions up to 8 GHz  
D-Sub male connector

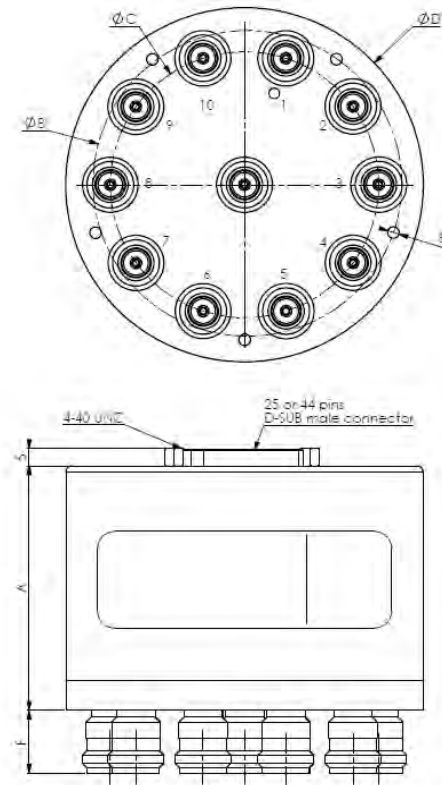

### RF CONNECTORS ALLOCATION

See on page 5-25 and 5-26

**SPnT Terminated & non Terminated up to 40 GHz**

SMA - SMA 2.9 - QMA - DIN 1.6 / 5.6

**RF CONNECTORS ALLOCATION FOR SPNT SERIES**

Connectors A: 1.6/5.6, QMA, SMA, SMA 2.9

Other Connectors: N, BNC, TNC

SPnT 3 ways			
NON TERMINATED Version		TERMINATED Version	
Up to 40 GHz models Without option Connectors A	Up to 40 GHz models With option Connectors A and other connectors	Up to 22 GHz models Connectors A and other connectors	26.5 GHz and 40 GHz models with SMA - SMA 2.9
SPnT 4 ways			
NON TERMINATED Version		TERMINATED Version	
Up to 40 GHz models Without option Connectors A	Up to 40 GHz models With option Connectors A and other connectors	Up to 22 GHz models Connectors A and other connectors	26.5 GHz and 40 GHz models with SMA - SMA 2.9
SPnT 5 ways			
NON TERMINATED Version		TERMINATED Version	
Up to 40 GHz models Without option Connectors A	Up to 40 GHz models With option Connectors A and other connectors	Up to 22 GHz models Connectors A and other connectors	26.5 GHz and 40 GHz models with SMA - SMA 2.9

**SPnT Terminated & non Terminated up to 40 GHz**

SMA – SMA 2.9 – QMA - DIN 1.6 / 5.6

**RF CONNECTORS ALLOCATION (CONTINUED)**

Connectors A: 1.6/5.6, QMA, SMA, SMA 2.9

Other Connectors: N, BNC, TNC

SPnT 6 ways			
NON TERMINATED Version		TERMINATED Version	
Up to 40 GHz models Without Option Connectors A	Up to 40 GHz models With Option Connectors A and other connectors	Up to 22 GHz models Connectors A and other connectors	26.5 GHz and 40 GHz models with SMA - SMA 2.9

SPnT 7 and 8 ways	SPnT 9 and 10 ways	SPnT 11 and 12 ways
All connectors	All connectors	All connectors

**ACCESSORIES**

A printed circuit board interface connector has been designed for easy mounting on terminals (must be ordered separately). Refer to page 5-27 for details.

Accessories - RAMSES Concept

N - BNC - TNC

PRINTED CIRCUIT BOARD INTERFACE CONNECTOR

A printed circuit board interface connector (ordered separately) has been designed for easy mounting on terminals.

For SPnT model R573 and R574 series: Radiall part number: **R599 906 000 for 3 to 6 positions**

**R599 908 000 for 7 to 8 positions**

**R599 900 000 for 9 to 10 positions**

**R599 902 000 for 11 to 12 positions**

R599906000

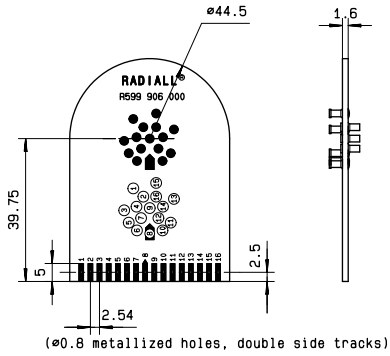

R599902000

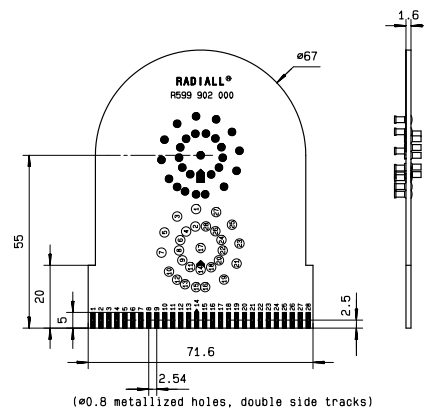

R599908000

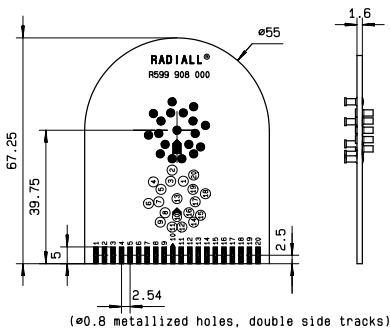

R599900000

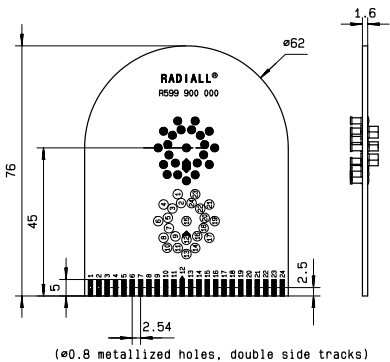

RAMSES SERIES

## Accessories - RAMSES Concept

### All Connectors

#### MOUNTING BRACKET

A metal bracket has been designed for an easy mechanical mounting of our SPnT switches for customer installation. These brackets must be ordered separately and assembled according to our recommended process on the following page.

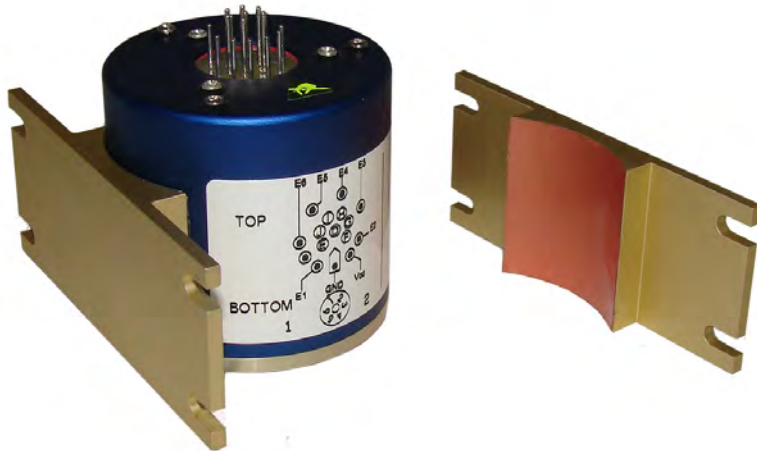

#### MOUNTING BRACKET

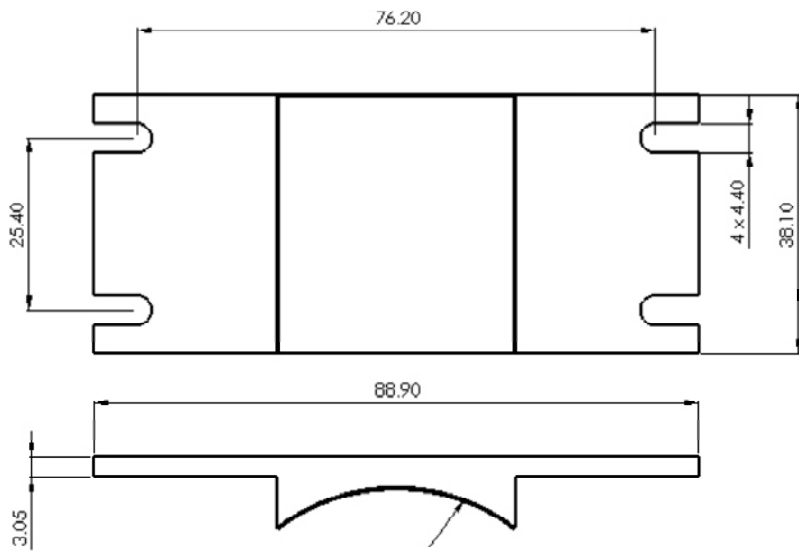

protective adhesive tape surface

Material: anodized aluminium

## Accessories - RAMSES Concept

### All Connectors

#### FOR MODELS WITH CONNECTORS SMA, QMA, SMA 2.9, DIN 1.6/5.6

Number of positions	Type	Options	Model	Part number
3 to 6 positions	All	2 & 8	R573 series	R599920000
	4, 5, 8, & 9	All		
	All	All	R574 series	
7 & 8 positions	All	All	R573 series	R599920000
			R574 series	
9 & 10 positions	All	All	R573 series	R599921000
			R574 series	
11 & 12 positions	All	All	R573 series	R599921000
			R574 series	

#### FOR MODELS WITH CONNECTORS N, TNC, BNC

Number of positions	Type	Options	Model	Part number
3 to 6 positions	All	All	R573 series	R599921000
			R574 series	
7 to 12 positions	All	All	R573 series	Not Available
			R574 series	

#### Adhesive Bonding Process

- 1) Clean the can with alcohol (Isopropanol or Ethanol).
- 2) Remove the protective adhesive tape surface.
- 3) Glue the mounting bracket ONLY on the blue can and NOT on the RF body.

DO NOT glue mounting bracket on the marking (See drawing).

- 4) Firmly press the mounting bracket against the can, and maintain pressure for several seconds (10 seconds min) to properly bond the unit (See notes 1 & 2).

- 5) The switch can now be installed on your equipment with 4 screws (not included).

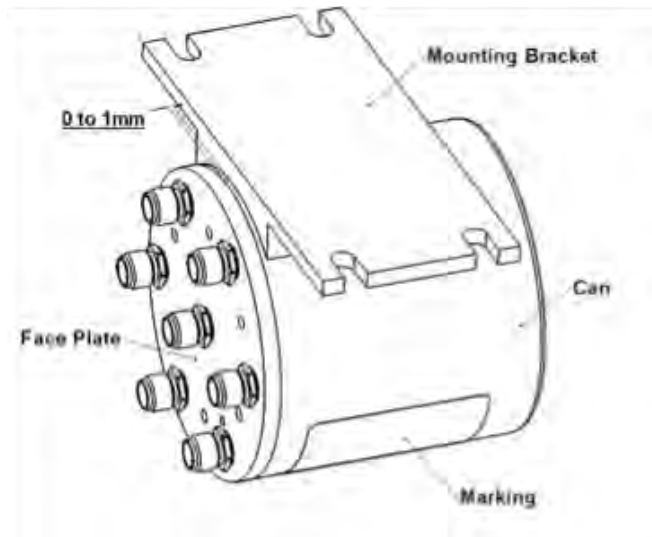

## Accessories - RAMSES Concept

### All Connectors

#### MOUNTING SQUARE FLANGE

A square flange has been designed for easy mechanical mounting of our SPnT switches for customer installation. These flanges must be ordered separately (similar to the mounting bracket) and assembled according to our recommended process



Typical Outline Drawing

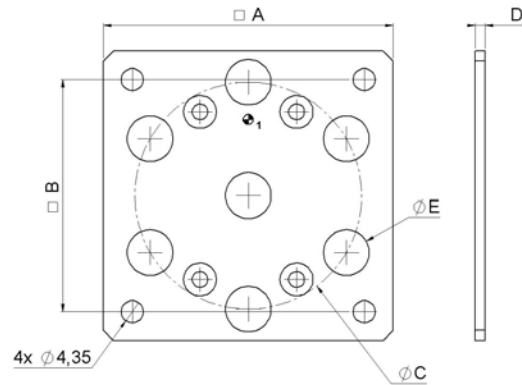

Material: Aluminium with Cr3 passivation

Radiall part number	A (mm)	B (mm)	C (mm)	D (mm)	E (mm)
R599 308 000	57.15	45.75	27	2	9
R599 309 000	57.15	45.75	44.70	2	9
R599 310 000	63.45	53.45	27	2	9
R599 311 000	63.45	53.45	44.70	2	9
R599 312 000	63.45	53.45	44.70	2	9
R599 313 000	69.80	59.80	44.70	2	9
R599 314 000	74.60	64.60	55.88	2	9
R599 315 000	71.10	60.30	44.70	3	16.20

#### FOR MODELS WITH CONNECTORS SMA, QMA, SMA2.9, 1.6/5.6

Number of positions	Type	Options	Model	Part number
3 to 6 positions	All	All	R573 series	R599310000
				R599308000
			R574 series	R599311000
				R599309000
7 to 8 positions	All	All	R573 series	R599312000
			R574 series	
9 to 10 positions	All	All	R573 series	R599313000
			R574 series	
11 to 12 positions	All	All	R573 series	R599314000
			R574 series	

#### FOR MODELS WITH CONNECTORS N, TNC, BNC

Number of positions	Type	Options	Model	Part number
3 to 6 positions	All	All	R573 series	R599315000
			R574 series	

## Accessories - RAMSES Concept

### All Connectors

#### D-SUB CONNECTOR LOCATION

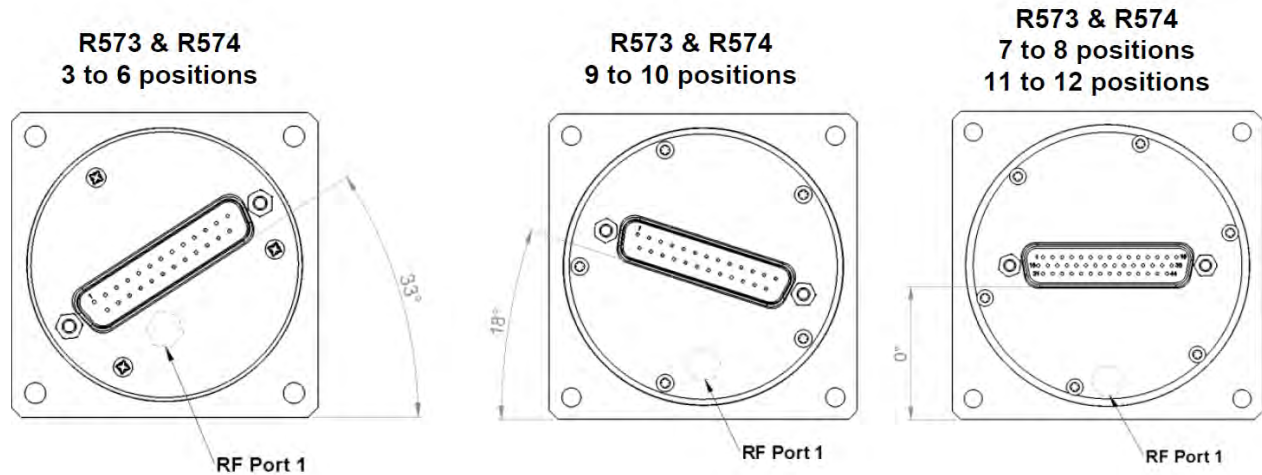

#### ASSEMBLY INSTRUCTIONS

- 1) Assemble the square flange on the RF body of the switch as the following drawing below.  
ATTENTION: Don't forget to correctly position the reference in line with the mark for port 1.
- 2) Tighten the 4 screws (delivered with the square flange).

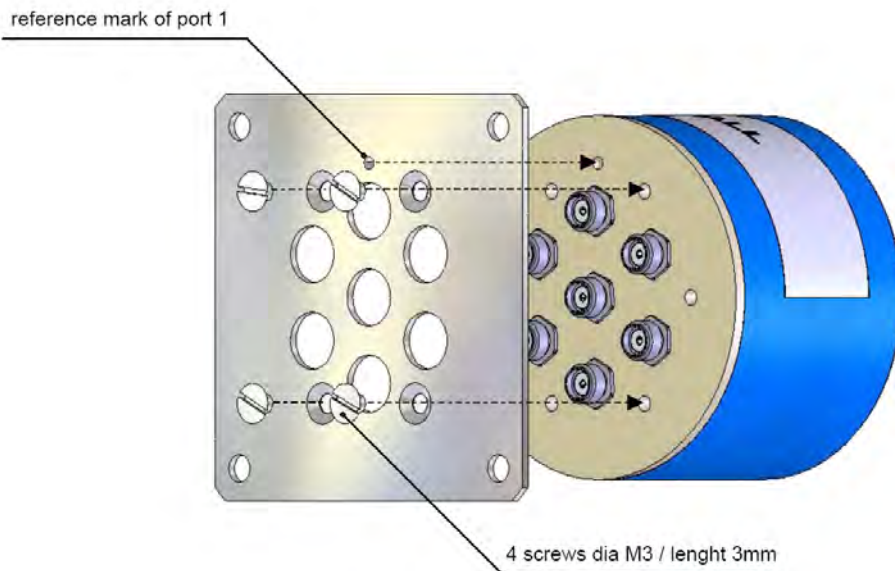



**COAXIAL SPnT - Electrical Schematics**

R573 - R574 Series

**NORMALLY OPEN**

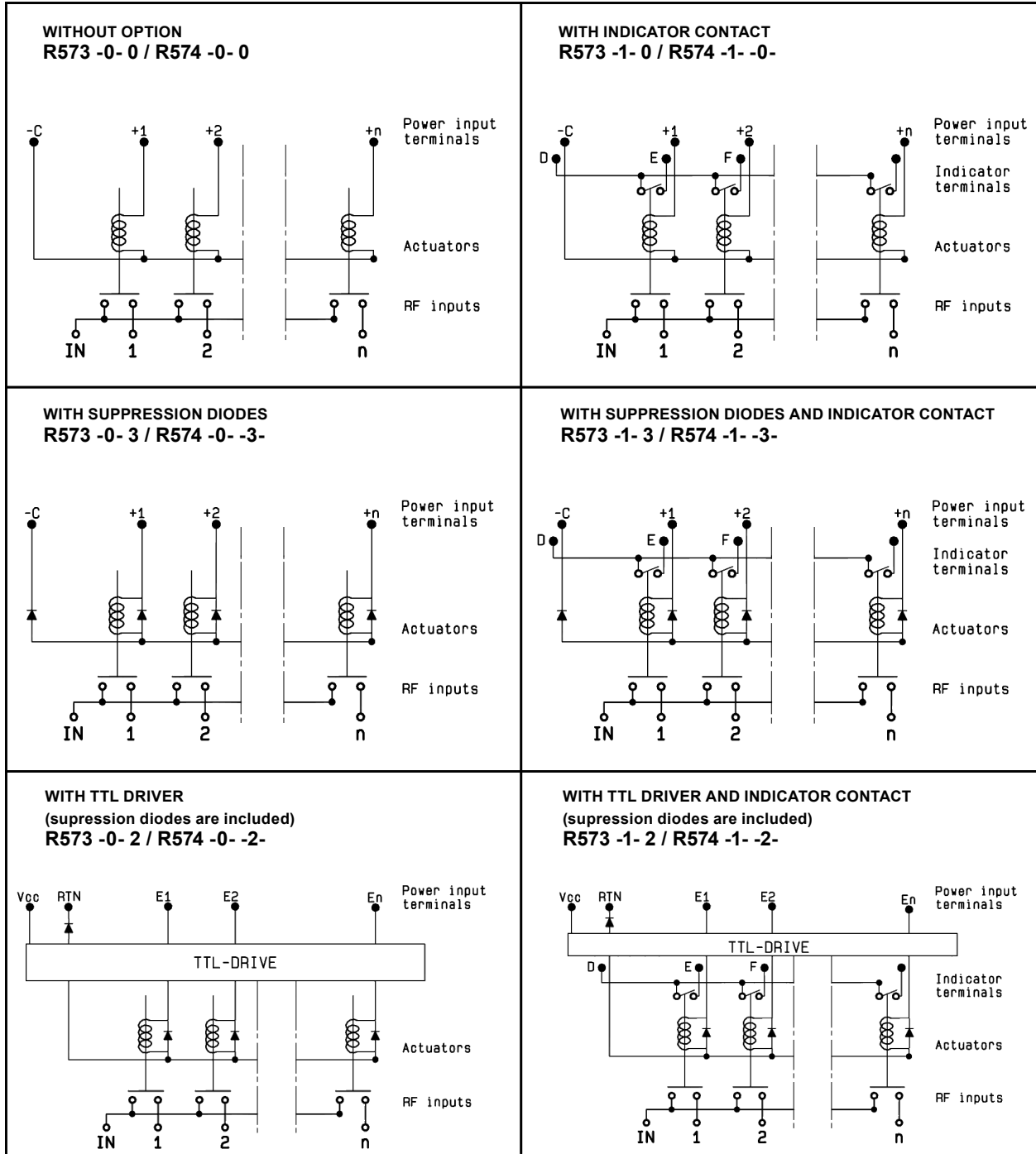

**COAXIAL SPnT - Electrical Schematics**

R573 - R574 Series

**NORMALLY OPEN**

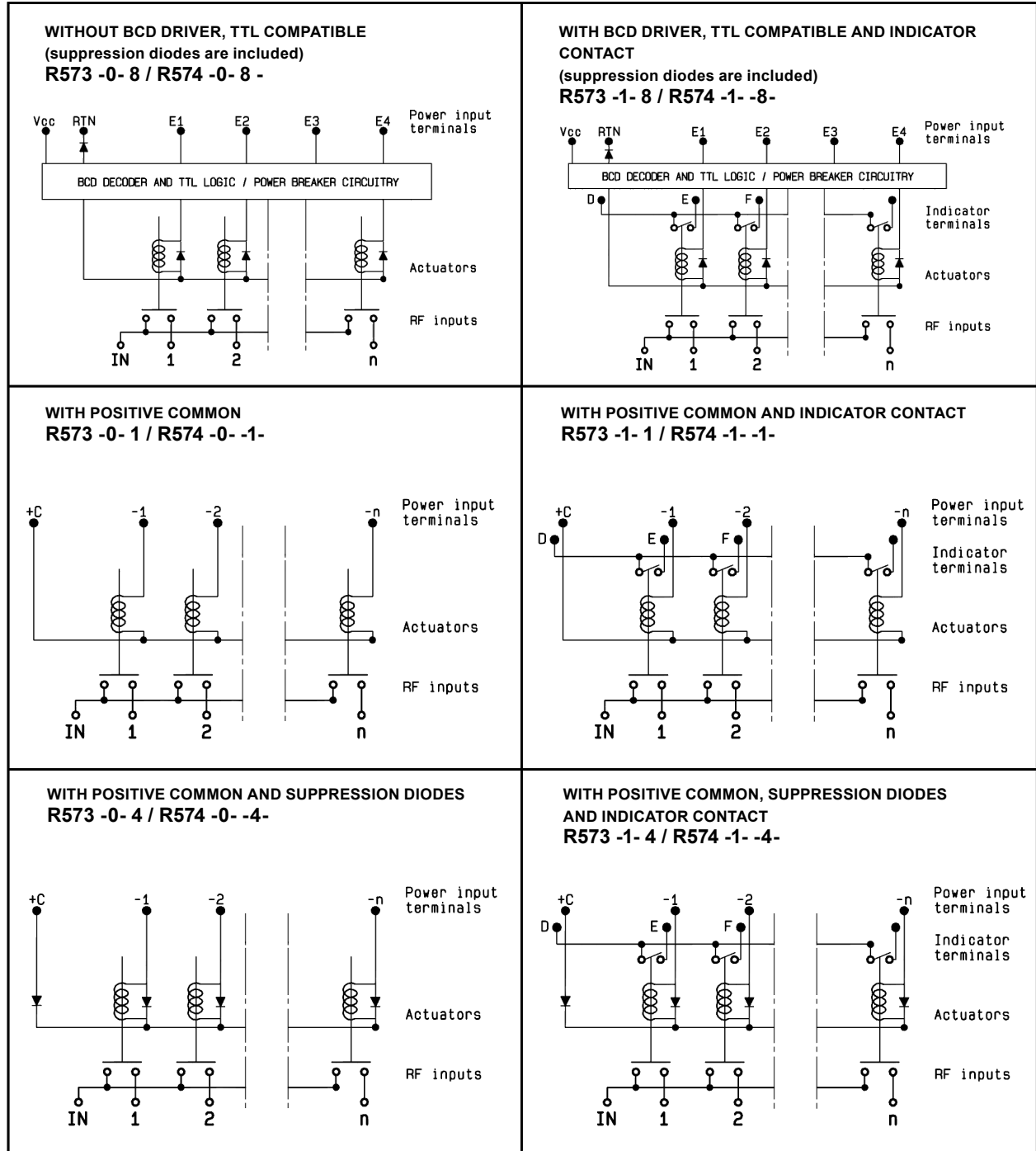

RAMSES SERIES

**COAXIAL SPnT - Electrical Schematics**

R573 - R574 Series

**LATCHING**

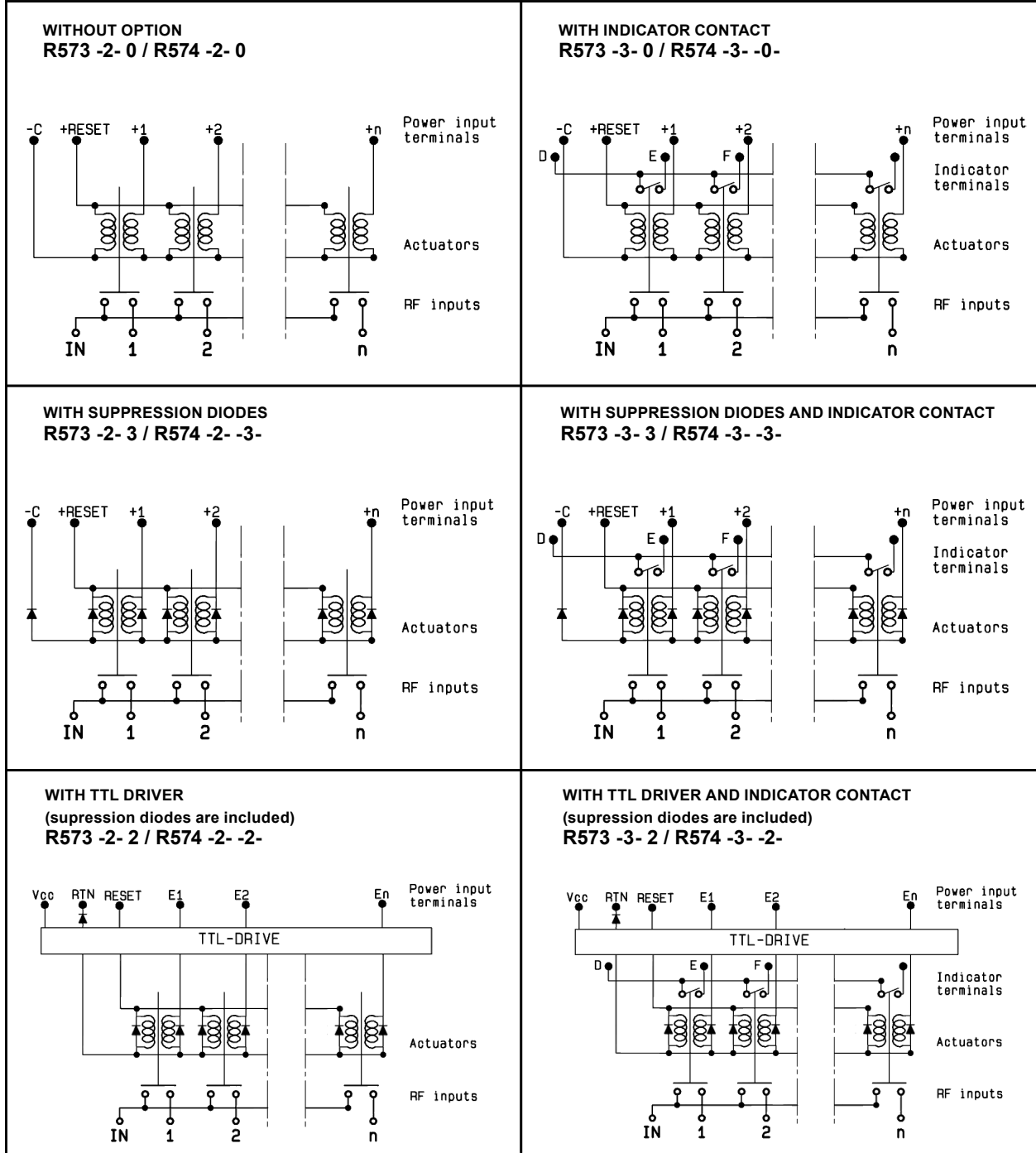

**COAXIAL SPnT - Electrical Schematics**

R573 - R574 Series

RAMSES SERIES

**LATCHING**

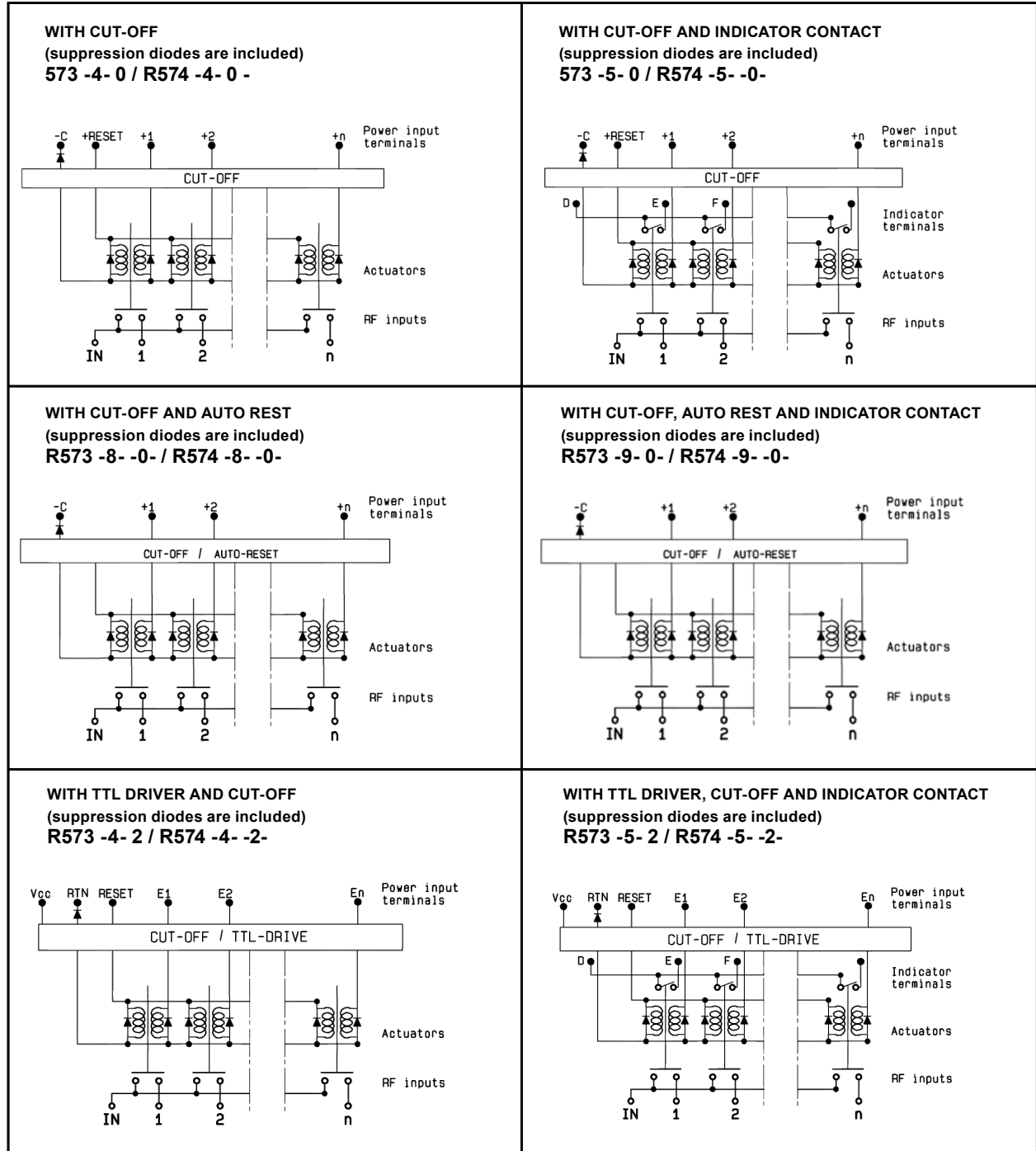

**COAXIAL SPnT - Electrical Schematics**

R573 - R574 Series

**LATCHING**

