

Ultra low power 48 MHz Arm® Cortex®-M23 core, up to 64-KB code flash memory, 8-KB SRAM, 12-bit A/D Converter, Security and Safety features.

Features

- **Arm Cortex-M23 Core**
 - Armv8-M architecture
 - Maximum operating frequency: 48 MHz
 - Arm Memory Protection Unit (Arm MPU) with 8 regions
 - Debug and Trace: DWT, FPB, CoreSight™ MTB-M23
 - CoreSight Debug Port: SW-DP
- **Memory**
 - Up to 64-KB code flash memory
 - 2-KB data flash memory (100,000 program/erase (P/E) cycles)
 - 8-KB SRAM
 - Memory protection units
 - 128-bit unique ID
- **Connectivity**
 - Serial Communications Interface (SCI) × 1
 - Asynchronous interfaces
 - 8-bit clock synchronous interface
 - Simple IIC
 - Simple SPI
 - Smart card interface
 - Serial Peripheral Interface (SPI) × 1
 - I3C bus interface (I3C) × 1
- **Analog**
 - 12-bit A/D Converter (ADC12)
 - Temperature Sensor (TSN)
- **Timers**
 - General PWM Timer 16-bit (GPT16) × 6
 - Low Power Asynchronous General Purpose Timer (AGTW) × 2
 - Watchdog Timer (WDT)
- **Safety**
 - SRAM parity error check
 - Flash area protection
 - ADC self-diagnosis function
 - Clock Frequency Accuracy Measurement Circuit (CAC)
 - Cyclic Redundancy Check (CRC) calculator
 - Data Operation Circuit (DOC)
 - Port Output Enable for GPT (POEG)
 - Independent Watchdog Timer (IWDT)
 - GPIO readback level detection
 - Register write protection
 - Illegal memory access detection
- **Security and Encryption**
 - AES128/256
 - True Random Number Generator (TRNG)
- **System and Power Management**
 - Low power modes
 - Event Link Controller (ELC)
 - Data Transfer Controller (DTC)
 - Key Interrupt Function (KINT)
 - Power-on reset
 - Low Voltage Detection (LVD) with voltage settings
- **Multiple Clock Sources**
 - High-speed on-chip oscillator (HOCO) (24/32/48/64 MHz)
 - Middle-speed on-chip oscillator (MOCO) (8 MHz)
 - Low-speed on-chip oscillator (LOCO) (32.768 kHz)
 - Clock trim function for HOCO/MOCO/LOCO
 - IWDT-dedicated on-chip oscillator (15 kHz)
 - Clock out support
- **Up to 20 pins for general I/O ports**
 - 5-V tolerance, open drain, input pull-up
- **Operating Voltage**
 - VCC: 1.6 to 5.5 V
- **Operating Temperature and Packages**
 - Ta = -40°C to +85°C
 - 24-pin HWQFN (4 mm × 4 mm, 0.5 mm pitch)
 - 20-pin HWQFN (4 mm × 4 mm, 0.5 mm pitch)
 - 16-pin WLCSP (1.84 mm × 1.87 mm, 0.4 mm pitch)
 - Ta = -40°C to +105°C
 - 24-pin HWQFN (4 mm × 4 mm, 0.5 mm pitch)
 - 20-pin HWQFN (4 mm × 4 mm, 0.5 mm pitch)
 - 16-pin WLCSP (1.84 mm × 1.87 mm, 0.4 mm pitch)
 - Ta = -40°C to +125°C
 - 24-pin HWQFN (4 mm × 4 mm, 0.5 mm pitch)
 - 20-pin HWQFN (4 mm × 4 mm, 0.5 mm pitch)
 - 16-pin WLCSP (1.84 mm × 1.87 mm, 0.4 mm pitch)

1. Overview

The MCU integrates multiple series of software- and pin-compatible Arm[®]-based 32-bit cores that share a common set of Renesas peripherals to facilitate design scalability.

The MCU in this series incorporates an energy-efficient Arm Cortex[®]-M23 32-bit core, that is particularly well suited for cost-sensitive and low-power applications, with the following features:

- Up to 64-KB code flash memory
- 8-KB SRAM
- 12-bit A/D Converter (ADC12)
- Security features

1.1 Function Outline

Table 1.1 Arm core

Feature	Functional description
Arm Cortex-M23 core	<ul style="list-style-type: none"> • Maximum operating frequency: up to 48 MHz • Arm Cortex-M23 core: <ul style="list-style-type: none"> – Revision: r1p0-00rel0 – Armv8-M architecture profile – Single-cycle integer multiplier – 19-cycle integer divider • Arm Memory Protection Unit (Arm MPU): <ul style="list-style-type: none"> – Armv8 Protected Memory System Architecture – 8 protect regions • SysTick timer: <ul style="list-style-type: none"> – Driven by SYSTICCLK (LOCO) or ICLK

Table 1.2 Memory

Feature	Functional description
Code flash memory	Maximum 64-KB of code flash memory.
Data flash memory	2-KB of data flash memory.
Option-setting memory	The option-setting memory determines the state of the MCU after a reset.
SRAM	On-chip high-speed SRAM with parity bit.

Table 1.3 System (1 of 2)

Feature	Functional description
Operating modes	Two operating modes: <ul style="list-style-type: none"> • Single-chip mode • SCI boot mode
Resets	The MCU provides 12 resets (RES pin reset, power-on reset, independent watchdog timer reset, watchdog timer reset, voltage monitor 0/1/2 resets, SRAM parity error reset, bus master/slave MPU error resets, CPU stack pointer error reset, software reset).
Low Voltage Detection (LVD)	The Low Voltage Detection (LVD) module monitors the voltage level input to the VCC pin. The detection level can be selected by register settings. The LVD module consists of three separate voltage level detectors (LVD0, LVD1, LVD). LVD0, LVD1, and LVD measure the voltage level input to the VCC pin. LVD registers allow your application to configure detection of VCC changes at various voltage thresholds.
Clocks	<ul style="list-style-type: none"> • High-speed on-chip oscillator (HOCO) • Middle-speed on-chip oscillator (MOCO) • Low-speed on-chip oscillator (LOCO) • IWDT-dedicated on-chip oscillator • Clock out support

Table 1.3 System (2 of 2)

Feature	Functional description
Clock Frequency Accuracy Measurement Circuit (CAC)	The Clock Frequency Accuracy Measurement Circuit (CAC) counts pulses of the clock to be measured (measurement target clock) within the time generated by the clock selected as the measurement reference (measurement reference clock), and determines the accuracy depending on whether the number of pulses is within the allowable range. When measurement is complete or the number of pulses within the time generated by the measurement reference clock is not within the allowable range, an interrupt request is generated.
Interrupt Controller Unit (ICU)	The Interrupt Controller Unit (ICU) controls which event signals are linked to the Nested Vector Interrupt Controller (NVIC), and the Data Transfer Controller (DTC) modules. The ICU also controls non-maskable interrupts.
Key Interrupt Function (KINT)	The key interrupt function (KINT) generates the key interrupt by detecting rising or falling edge on the key interrupt input pins.
Low power modes	Power consumption can be reduced in multiple ways, including setting clock dividers, stopping modules, selecting power control mode in normal operation, and transitioning to low power modes.
Register write protection	The register write protection function protects important registers from being overwritten due to software errors. The registers to be protected are set with the Protect Register (PRCR).
Memory Protection Unit (MPU)	The MCU has four Memory Protection Units (MPUs) and a CPU stack pointer monitor function are provided.
Watchdog Timer (WDT)	The Watchdog Timer (WDT) is a 14-bit down counter that can be used to reset the MCU when the counter underflows because the system has run out of control and is unable to refresh the WDT. In addition, the WDT can be used to generate a non-maskable interrupt or an underflow interrupt or watchdog timer reset.
Independent Watchdog Timer (IWDT)	The Independent Watchdog Timer (IWDT) consists of a 14-bit down counter that must be serviced periodically to prevent counter underflow. The IWDT provides functionality to reset the MCU or to generate a non-maskable interrupt or an underflow interrupt. Because the timer operates with an independent, dedicated clock source, it is particularly useful in returning the MCU to a known state as a fail-safe mechanism when the system runs out of control. The IWDT can be triggered automatically by a reset, underflow, refresh error, or a refresh of the count value in the registers.

Table 1.4 Event link

Feature	Functional description
Event Link Controller (ELC)	The Event Link Controller (ELC) uses the event requests generated by various peripheral modules as source signals to connect them to different modules, allowing direct link between the modules without CPU intervention.

Table 1.5 Direct memory access

Feature	Functional description
Data Transfer Controller (DTC)	A Data Transfer Controller (DTC) module is provided for transferring data when activated by an interrupt request.

Table 1.6 Timers

Feature	Functional description
General PWM Timer (GPT)	The General PWM Timer (GPT) is a 16-bit timer with GPT16 × channels. PWM waveforms can be generated by controlling the up-counter, down-counter, or the up- and down-counter. In addition, PWM waveforms can be generated for controlling brushless DC motors. The GPT can also be used as a general-purpose timer.
Port Output Enable for GPT (POEG)	The Port Output Enable (POEG) function can place the General PWM Timer (GPT) output pins in the output disable state
Low power Asynchronous General Purpose Timer (AGTW)	The Low Power Asynchronous General Purpose Timer (AGTW) is a 32-bit timer that can be used for pulse output, external pulse width or period measurement, and counting external events. This timer consists of a reload register and a down counter. The reload register and the down counter are allocated to the same address, and can be accessed with the AGT register.

Table 1.7 Communication interfaces

Feature	Functional description
Serial Communications Interface (SCI)	<p>The Serial Communications Interface (SCI) × channel has asynchronous and synchronous serial interface:</p> <ul style="list-style-type: none"> Asynchronous interfaces (UART and Asynchronous Communications Interface Adapter (ACIA)) 8-bit clock synchronous interface Simple IIC (master-only) Simple SPI Smart card interface <p>The smart card interface complies with the ISO/IEC 7816-3 standard for electronic signals and transmission protocol. The data transfer speed can be configured independently using an on-chip baud rate generator.</p>
I3C bus interface (I3C)	The bus interface (I3C) has 1 channel. The module conform with and provide a subset of the NXP I ² C (Inter-Integrated Circuit) bus interface functions and a subset of the MIPI I3C.
Serial Peripheral Interface (SPI)	The Serial Peripheral Interface (SPI) has 1 channel. The SPI provides high-speed full-duplex synchronous serial communications with multiple processors and peripheral devices.

Table 1.8 Analog

Feature	Functional description
12-bit A/D Converter (ADC12)	A 12-bit successive approximation A/D converter is provided. Up to 8 analog input channels are selectable. Temperature sensor output and internal reference voltage are selectable for conversion.
Temperature Sensor (TSN)	The on-chip Temperature Sensor (TSN) determines and monitors the die temperature for reliable operation of the device. The sensor outputs a voltage directly proportional to the die temperature, and the relationship between the die temperature and the output voltage is fairly linear. The output voltage is provided to the for conversion and can be further used by the end application.

Table 1.9 Data processing

Feature	Functional description
Cyclic Redundancy Check (CRC) calculator	The Cyclic Redundancy Check (CRC) generates CRC codes to detect errors in the data. The bit order of CRC calculation results can be switched for LSB-first or MSB-first communication. Additionally, various CRC-generation polynomials are available. The snoop function allows to monitor the access to specific addresses. This function is useful in applications that require CRC code to be generated automatically in certain events, such as monitoring writes to the serial transmit buffer and reads from the serial receive buffer.
Data Operation Circuit (DOC)	The Data Operation Circuit (DOC) compares, adds, and subtracts 16-bit data. When a selected condition applies, 16-bit data is compared and an interrupt can be generated.

Table 1.10 I/O ports

Feature	Functional description
I/O ports	<ul style="list-style-type: none"> I/O ports for the 24-pin HWQFN <ul style="list-style-type: none"> I/O pins: 19 Input pins: 1 Pull-up resistors: 19 N-ch open-drain outputs: 15 5-V tolerance: 2 I/O ports for the 20-pin HWQFN <ul style="list-style-type: none"> I/O pins: 15 Input pins: 1 Pull-up resistors: 15 N-ch open-drain outputs: 12 5-V tolerance: 2

1.2 Block Diagram

Figure 1.1 shows a block diagram of the MCU superset. Some individual devices within the group have a subset of the features.

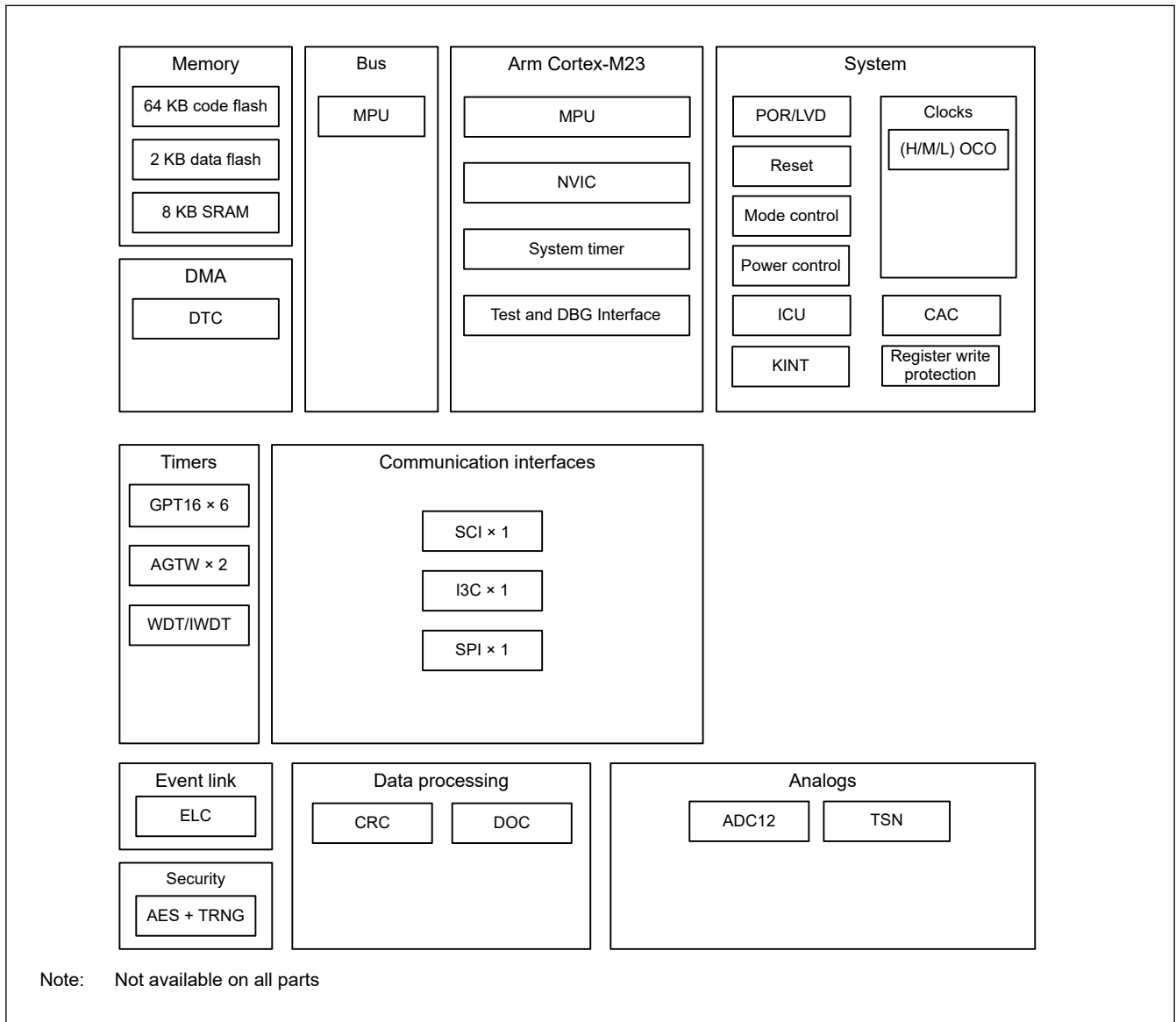

Figure 1.1 Block diagram

1.3 Part Numbering

Figure 1.2 shows the product part number information, including memory capacity and package type. Table 1.11 shows a list of products.

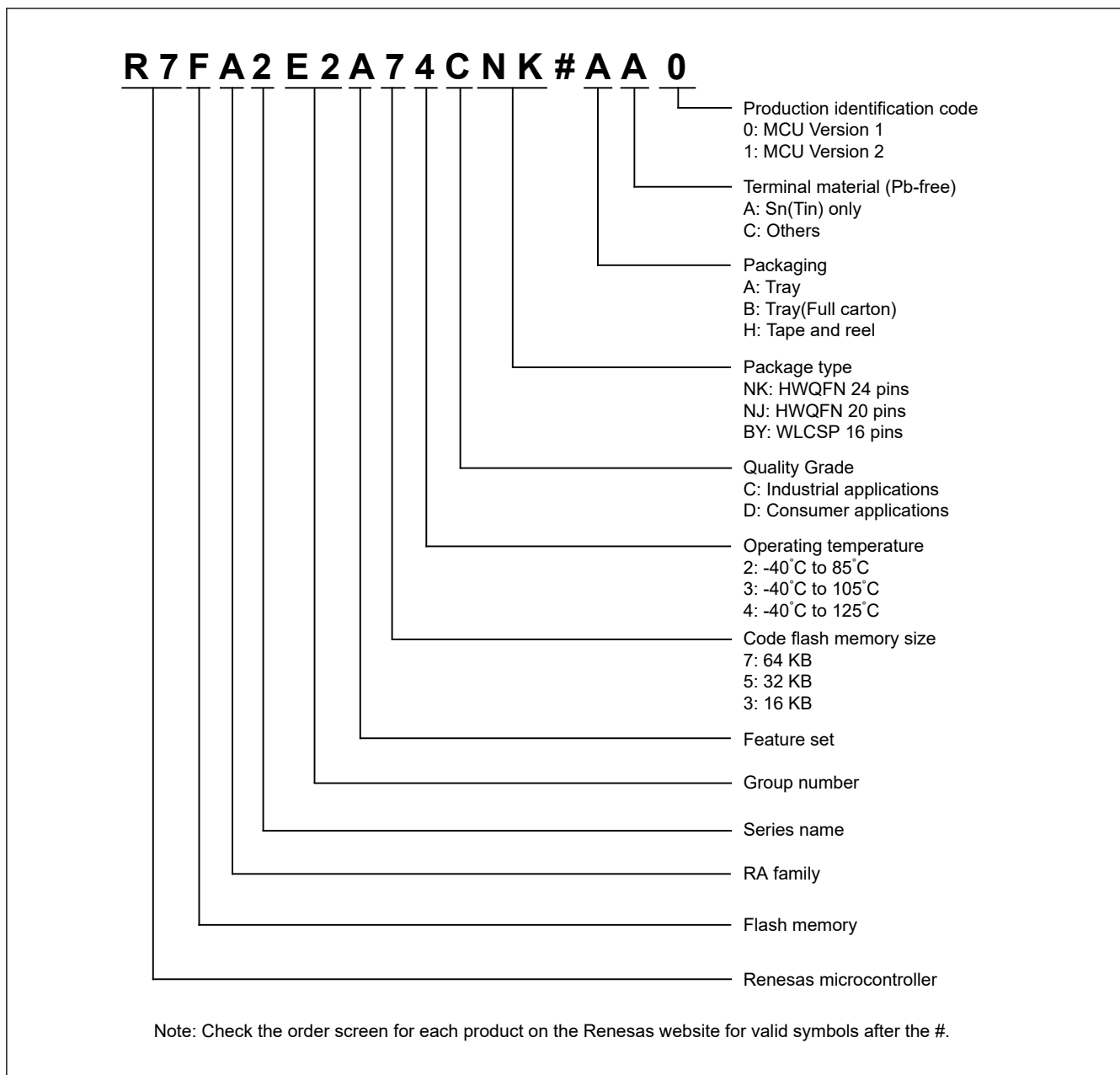

Figure 1.2 Part numbering scheme

Table 1.11 Product list (1 of 2)

Product part number	Package code	Code flash	Data flash	SRAM	Operating temperature
R7FA2E2A74CNK	PWQN0024KG-A	64	2	8	-40 to +125°C
R7FA2E2A74CNJ	PWQN0020KC-A				
R7FA2E2A73CNK	PWQN0024KG-A	64	2	8	-40 to +105°C
R7FA2E2A73CNJ	PWQN0020KC-A				
R7FA2E2A72DNK	PWQN0024KG-A	64	2	8	-40 to +85°C
R7FA2E2A72DNJ	PWQN0020KC-A				

Table 1.11 Product list (2 of 2)

Product part number	Package code	Code flash	Data flash	SRAM	Operating temperature
R7FA2E2A54CNK	PWQN0024KG-A	32	2	8	-40 to +125°C
R7FA2E2A54CNJ	PWQN0020KC-A				-40 to +105°C
R7FA2E2A53CNK	PWQN0024KG-A				-40 to +85°C
R7FA2E2A53CNJ	PWQN0020KC-A				
R7FA2E2A52DNK	PWQN0024KG-A				
R7FA2E2A52DNJ	PWQN0020KC-A				
R7FA2E2A34CNK	PWQN0024KG-A	16	2	8	-40 to +125°C
R7FA2E2A34CNJ	PWQN0020KC-A				-40 to +105°C
R7FA2E2A33CNK	PWQN0024KG-A				-40 to +85°C
R7FA2E2A33CNJ	PWQN0020KC-A				
R7FA2E2A32DNK	PWQN0024KG-A				
R7FA2E2A32DNJ	PWQN0020KC-A				
R7FA2E2A74CBY	SUBG0016LB-A	64	2	8	-40 to +125°C
R7FA2E2A73CBY	SUBG0016LB-A				-40 to +105°C
R7FA2E2A72DBY	SUBG0016LB-A				-40 to +85°C
R7FA2E2A54CBY	SUBG0016LB-A	32	2	8	-40 to +125°C
R7FA2E2A53CBY	SUBG0016LB-A				-40 to +105°C
R7FA2E2A52DBY	SUBG0016LB-A				-40 to +85°C
R7FA2E2A34CBY	SUBG0016LB-A	16	2	8	-40 to +125°C
R7FA2E2A33CBY	SUBG0016LB-A				-40 to +105°C
R7FA2E2A32DBY	SUBG0016LB-A				-40 to +85°C

1.4 Function Comparison

Table 1.12 Function Comparison

Parts number		R7FA2E2A7xxNK	R7FA2E2A5xxNK	R7FA2E2A3xxNK	R7FA2E2A7xxNJ	R7FA2E2A5xxNJ	R7FA2E2A3xxNJ	R7FA2E2A7xxBY	R7FA2E2A5xxBY	R7FA2E2A3xxBY
Pin count		24			20			16		
Package		HWQFN			HWQFN			WLCSP		
Code flash memory		64 KB	32 KB	16 KB	64 KB	32 KB	16 KB	64 KB	32 KB	16 KB
Data flash memory		2 KB			2 KB			2 KB		
SRAM(Parity)		8 KB			8 KB			8 KB		
System	CPU clock	48 MHz			48 MHz			48 MHz		
	ICU	Yes			Yes			Yes		
	KINT	4			4			4		
Event control	ELC	Yes			Yes			Yes		
DMA	DTC	Yes			Yes			Yes		
Timers	GPT16	6 (PWM outputs: 12)			6 (PWM outputs: 11)			6 (PWM outputs: 10)		
	AGTW	2			2			2		
	WDT/IWDT	Yes			Yes			Yes		
Communication	SCI	1			1			1		
	I3C	1			1			1		
	SPI	1			1			1		
Analog	ADC12	8			7			4		
	TSN	Yes			Yes			Yes		
Data processing	CRC	Yes			Yes			Yes		
	DOC	Yes			Yes			Yes		
Security		AES & TRNG			AES & TRNG			AES & TRNG		
I/O ports	I/O pins	19			15			11		
	Input pins	1			1			1		
	Pull-up resistors	19			15			11		
	N-ch open-drain outputs	15			12			11		
	5-V tolerance	2			2			2		

1.5 Pin Functions

Table 1.13 Pin functions (1 of 2)

Function	Signal	I/O	Description
Power supply	VCC	Input	Power supply pin. Connect it to the system power supply. Connect this pin to VSS by a 0.1- μ F capacitor. Place the capacitor close to the pin.
	VCL	I/O	Connect this pin to the VSS pin by the smoothing capacitor used to stabilize the internal power supply. Place the capacitor close to the pin.
	VSS	Input	Ground pin. Connect it to the system power supply (0 V).
Clock	CLKOUT	Output	Clock output pin
Operating mode control	MD	Input	Pin for setting the operating mode. The signal level on this pin must not be changed during operation mode transition on release from the reset state.
System control	RES	Input	Reset signal input pin. The MCU enters the reset state when this signal goes low.
CAC	CACREF	Input	Measurement reference clock input pin
On-chip debug	SWDIO	I/O	Serial wire debug data input/output pin
	SWCLK	Input	Serial wire clock pin
Interrupt	NMI	Input	Non-maskable interrupt request pin
	IRQ0 to IRQ7	Input	Maskable interrupt request pins
GPT	GTETRGA, GTETRGB	Input	External trigger input pins
	GTIOcNA (n = 4 to 9), GTIOcNB (n = 4 to 9)	I/O	Input capture, output compare, or PWM output pins
	GTOUUP	Output	3-phase PWM output for BLDC motor control (positive U phase)
	GTOULO	Output	3-phase PWM output for BLDC motor control (negative U phase)
	GTOVUP	Output	3-phase PWM output for BLDC motor control (positive V phase)
	GTOVLO	Output	3-phase PWM output for BLDC motor control (negative V phase)
	GTOUWP	Output	3-phase PWM output for BLDC motor control (positive W phase)
	GTOWLO	Output	3-phase PWM output for BLDC motor control (negative W phase)
AGTW	AGTEE0, AGTEE1	Input	External event input enable signals
	AGTIO0, AGTIO1	I/O	External event input and pulse output pins
	AGTO0, AGTO1	Output	Pulse output pins
	AGTOA0, AGTOA1	Output	Output compare match A output pins
	AGTOB0, AGTOB1	Output	Output compare match B output pins

Table 1.13 Pin functions (2 of 2)

Function	Signal	I/O	Description
SCI	SCKn (n = 9)	I/O	Input/output pins for the clock (clock synchronous mode)
	RXDn (n = 9)	Input	Input pins for received data (asynchronous mode/clock synchronous mode)
	TXDn (n = 9)	Output	Output pins for transmitted data (asynchronous mode/clock synchronous mode)
	CTS _n _RTS _n (n = 9)	I/O	Input/output pins for controlling the start of transmission and reception (asynchronous mode/clock synchronous mode), active-low.
	SCLn (n = 9)	I/O	Input/output pins for the IIC clock (simple IIC mode)
	SDAn (n = 9)	I/O	Input/output pins for the IIC data (simple IIC mode)
	SCKn (n = 9)	I/O	Input/output pins for the clock (simple SPI mode)
	MISO _n (n = 9)	I/O	Input/output pins for slave transmission of data (simple SPI mode)
	MOSI _n (n = 9)	I/O	Input/output pins for master transmission of data (simple SPI mode)
	SS _n (n = 9)	Input	Chip-select input pins (simple SPI mode), active-low
I3C	SCLn (n = 0)	I/O	Input/output pins for the clock
	SDAn (n = 0)	I/O	Input/output pins for data
SPI	RSPCKA	I/O	Clock input/output pin
	SSLA0	I/O	Input or output pin for slave selection
	MOSIA	I/O	Input or output pins for data output from the master
	MISOA	I/O	Input or output pins for data output from the slave
Analog power supply	VREFH0	Input	Analog reference voltage supply pin for the ADC12. Connect this pin to AVCC0 when not using the ADC12.
	VREFL0	Input	Analog reference ground pin for the ADC12. Connect this pin to AVSS0 when not using the ADC12.
ADC12	AN005, AN006, AN009, AN010, AN019 to AN022	Input	Input pins for the analog signals to be processed by the A/D converter.
	ADTRG0	Input	Input pin for the external trigger signals that start the A/D conversion, active-low.
KINT	KR00 to KR03	Input	Key interrupt input pins
I/O ports	P010, P011, P014, P015	I/O	General-purpose input/output pins
	P100 to P103, P108 to P112	I/O	General-purpose input/output pins
	P200	Input	General-purpose input pin
	P201, P205	I/O	General-purpose input/output pins
	P300	I/O	General-purpose input/output pins
	P400, P401	I/O	General-purpose input/output pins
	P914	I/O	General-purpose input/output pins

1.6 Pin Assignments

Figure 1.3 to Figure 1.5 show the pin assignments from the top view.

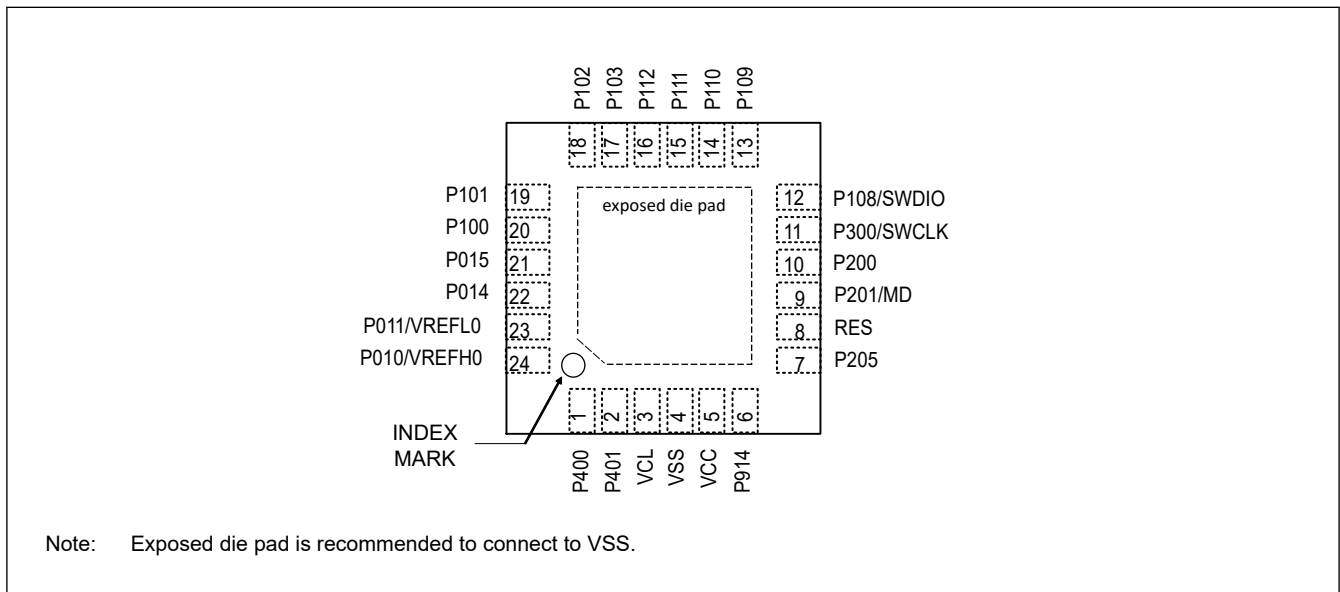

Figure 1.3 Pin assignment for HWQFN 24-pin (top view)

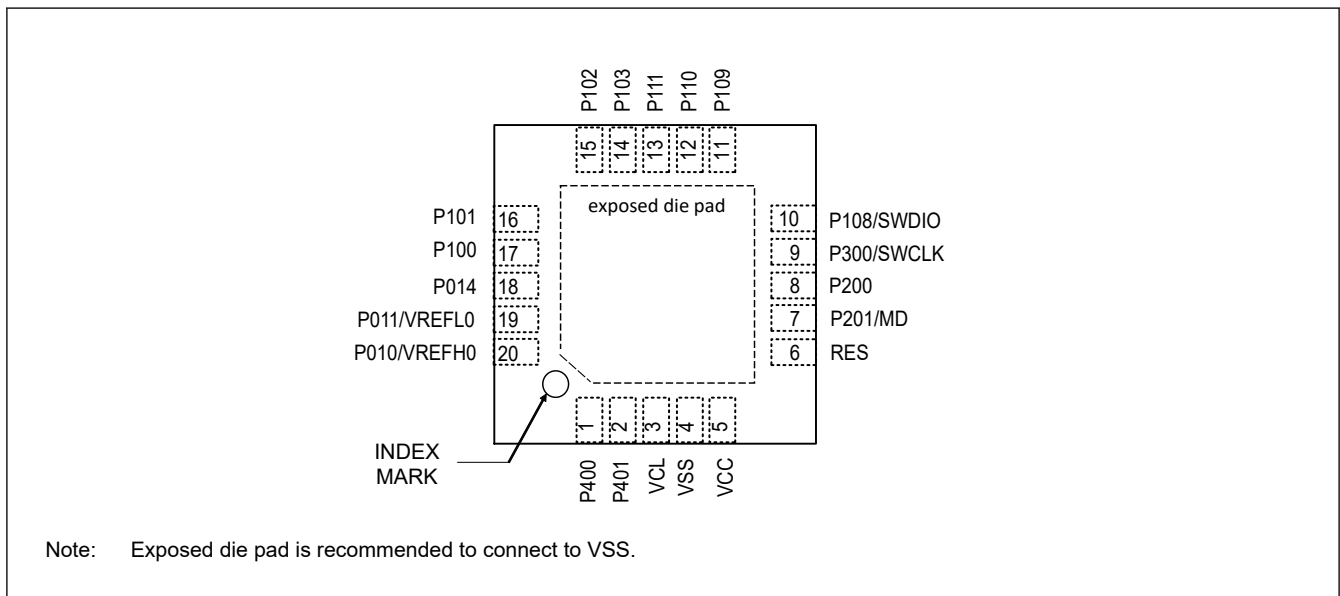

Figure 1.4 Pin assignment for HWQFN 20-pin (top view)

	A	B	C	D	
4	P103	P101	P100	P400	4
3	P110	P102	VCL	P401	3
2	P109	P200	VCC	VSS	2
1	P108/ SWDIO	P300/ SWCLK	P201/MD	RES	1
	A	B	C	D	

Figure 1.5 Pin assignment for WLCSP 16-pin (top view, pad side down)

1.7 Pin Lists

Table 1.14 Pin list

Pin number			Power, System, Clock, Debug, CAC	I/O ports	Timers			Communication interfaces				Analogs	HMI
HWQFN 24-pin	HWQFN 20-pin	WLCSP 16-pin			AGTW	GPT_OPS, PDEG	GPT	SCI9	SCI9	I3C	SPI	ADC	Interrupt
1	1	D4	CACREF_C	P400	AGTIO1_C	—	GTIOC9A_A	SCK9_D	TXD9_F/ MOSI9_F/ SDA9_F	SCL0_A	—	—	IRQ0_A/ KRM02_A
2	2	D3	—	P401	AGTEE1_A	GTETRG_A_B	GTIOC9B_A	CTS9_RTS9_F/ SS9_F	RxD9_F/ MISO9_F/ SCL9_F	SDA0_A	—	—	IRQ5/KRM03_A
3	3	C3	—	VCL	—	—	—	—	—	—	—	—	—
4	4	D2	VSS	—	—	—	—	—	—	—	—	—	—
5	5	C2	VCC	—	—	—	—	—	—	—	—	—	—
6	—	—	—	P914	AGTOA1_A	GTETRGB_F	—	RxD9_J/ MISO9_J/ SCL9_J	SCK9_H	—	—	—	IRQ2_C/ KRM00_A
7	—	—	CLKOUT_A	P205	AGTO1	—	—	TXD9_I/ MOSI9_I/ SDA9_I	CTS9_RTS9_A/ SS9_A	—	—	—	IRQ1/KRM01_A
8	6	D1	RES#	—	—	—	—	—	—	—	—	—	—
9	7	C1	MD	P201	—	—	—	—	—	—	—	—	—
10	8	B2	—	P200	—	—	—	—	—	—	—	—	NMI
11	9	B1	SWCLK	P300	AGTOB1_A	GTOUUP_C	GTIOC7A_C	RXD9_H/ MISO9_H/ SCL9_H	SCK9_G	—	RSPCKA_C	—	IRQ0_C
12	10	A1	SWDIO	P108	AGTOA1_B	GTOULO_C	GTIOC7B_C	TXD9_H/ MOSI9_H/ SDA9_H	CTS9_RTS9_B/ SS9_B	—	MOSIA_C	—	IRQ5_C
13	11	A2	CLKOUT_B	P109	AGTO1_A	GTOVUP_A	GTIOC4A_A	SCK9_F	TXD9_B/ MOSI9_B/ SDA9_B	—	MISOA_C	—	IRQ7_C/ KRM01_B
14	12	A3	—	P110	AGTOA0_A	GTOVLO_A	GTIOC4B_A	CTS9_RTS9_H/ SS9_H	RxD9_B/ MISO9_B/ SCL9_B	—	SSLA0_C	—	IRQ3_A/ KRM00_B
15	13	—	—	P111	AGTOA0	—	GTIOC6A_A	RXD9_G/ MISO9_G/ SCL9_G	SCK9_B	—	—	—	IRQ4_A/ KRM03_B
16	—	—	—	P112	AGTOB0	—	GTIOC6B_A	TXD9_J/ MOSI9_J/ SDA9_J	CTS9_RTS9_I/ SS9_I	—	—	—	IRQ1_C/ KRM02_B
17	14	A4	—	P103	AGTOB0_B	GTOVUP_A	GTIOC5A_A	CTS9_RTS9_E/ SS9_E	RxD9_I/ MISO9_I/ SCL9_I	—	SSLA0_A	AN019	IRQ6_C/KRM03
18	15	B3	—	P102	AGTO0	GTOVLO_A	GTIOC5B_A	SCK9_C	TXD9_G/ MOSI9_G/ SDA9_G	—	RSPCKA_A	AN020/ ADTRG0_A	IRQ4_C/KRM02
19	16	B4	—	P101	AGTEE0	GTETRGB_A	GTIOC8A_A	TXD9_E/ MOSI9_E/ SDA9_E	CTS9_RTS9_G/ SS9_G	—	MOSIA_A	AN021	IRQ1_A/KRM01
20	17	C4	—	P100	AGTIO0_A	GTETRG_A	GTIOC8B_A	RxD9_E/ MISO9_E/ SCL9_E	SCK9_E	—	MISOA_A	AN022	IRQ2_A/KRM00
21	—	—	—	P015	—	—	—	—	—	—	—	AN010	IRQ7_A
22	18	—	—	P014	—	—	—	—	—	—	—	AN009	—
23	19	—	VREFL0	P011	—	—	—	—	—	—	—	AN006	—
24	20	—	VREFH0	P010	—	—	—	—	—	—	—	AN005	—

Note: Several pin names have the added suffix of _A, _B, _C, _D, _E, _F, _G, _H, _I, and _J. The suffix can be ignored when assigning functionality.

2. Electrical Characteristics

Unless otherwise specified, the electrical characteristics of the MCU are defined under the following conditions:

$VCC^{*1} = 1.6$ to 5.5 V, $VREFH0 = 1.6$ V to $AVCC0$

$VSS = VREFL0 = 0$ V, $T_a = T_{opr}$

Note 1. The typical condition is set to $VCC = 3.3$ V.

Figure 2.1 shows the timing conditions.

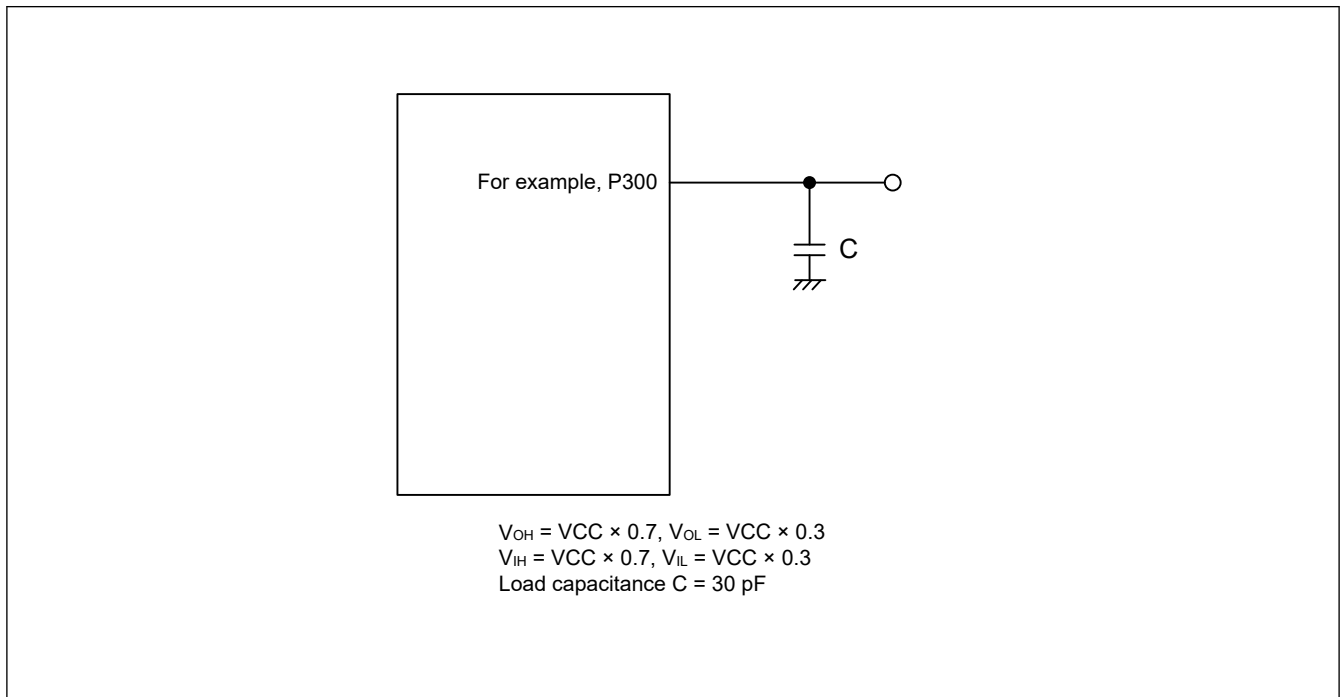

Figure 2.1 Input or output timing measurement conditions

The measurement conditions of the timing specifications for each peripheral are recommended for the best peripheral operation. However, make sure to adjust driving abilities for each pin to meet the conditions of your system.

Each function pin used for the same function must select the same drive ability. If the I/O drive ability of each function pin is mixed, the AC characteristics of each function are not guaranteed.

2.1 Absolute Maximum Ratings

Table 2.1 Absolute maximum ratings

Parameter	Symbol	Value	Unit
Power supply voltage	VCC	-0.5 to +6.5	V
Input voltage	5V-tolerant ports ^{*1}	V_{in}	-0.3 to +6.5
	Others	V_{in}	-0.3 to VCC + 0.3
Reference power supply voltage	VREFH0	-0.3 to +6.5	V
Analog input voltage	V_{AN}	-0.3 to VCC + 0.3	V
Operating temperature ^{*2 *3 *4}	T_{opr}	-40 to +85 -40 to +105 -40 to +125	°C
Storage temperature	T_{stg}	-55 to +140	°C

Note 1. Ports P400 and P401 are 5V-tolerant.

Do not input signals or an I/O pull-up power supply while the device is not powered. The current injection that results from input of such a signal or I/O pull-up might cause malfunction and the abnormal current that passes in the device at this time might cause degradation of internal elements.

Note 2. See [section 2.2.1. Tj/Ta Definition](#).

Note 3. Contact Renesas Electronics sales office for information on derating operation under $T_a = +85^{\circ}\text{C}$ to $+125^{\circ}\text{C}$.
Derating is the systematic reduction of load for improved reliability.

Note 4. The upper limit of the operating temperature is 85°C , 105°C or 125°C , depending on the product.

Caution: Permanent damage to the MCU may result if absolute maximum ratings are exceeded.

To preclude any malfunctions due to noise interference, insert capacitors with high frequency characteristics between the VCC and VSS pins, and between the VREFH0 and VREFL0 pins when VREFH0 is selected as the high potential reference voltage for the ADC12. Place capacitors of the following value as close as possible to every power supply pin and use the shortest and heaviest possible traces:

- VCC and VSS: about $0.1\ \mu\text{F}$
- VREFH0 and VREFL0: about $0.1\ \mu\text{F}$

Also, connect capacitors as stabilization capacitance.

Connect the VCL pin to a VSS pin by a $4.7\ \mu\text{F}$ capacitor. Each capacitor must be placed close to the pin.

Table 2.2 Recommended operating conditions

Parameter	Symbol	Min	Typ	Max	Unit	
Power supply voltages	VCC	1.6	—	5.5	V	
	VSS	—	0	—	V	
Analog power supply voltages	VREFH0	When used as ADC12 Reference	1.6	—	VCC	V
	VREFL0		—	0	—	V

2.2 DC Characteristics

2.2.1 T_j/T_a Definition

Table 2.3 DC characteristics

Conditions: Products with operating temperature (T_a) -40 to $+125^{\circ}\text{C}$

Parameter	Symbol	Typ	Max*1	Unit	Test conditions
Permissible junction temperature	T_j	—	140	$^{\circ}\text{C}$	High-speed mode Middle-speed mode Low-speed mode Subosc-speed mode
			125		
			105		
			105		

Note: Make sure that $T_j = T_a + \theta_{ja} \times \text{total power consumption (W)}$, where total power consumption = $(V_{CC} - V_{OH}) \times \Sigma I_{OH} + V_{OL} \times \Sigma I_{OL} + I_{CCmax} \times V_{CC}$.

Note 1. The upper limit of operating temperature is 85°C , 105°C or 125°C depending on the product. If the part number shows the operation temperature at 85°C , then the maximum value of T_j is 105°C , If the part number shows the operation temperature at 105°C , then the maximum value of T_j is 125°C , otherwise it is 140°C .

2.2.2 I/O V_{IH} , V_{IL} **Table 2.4** I/O V_{IH} , V_{IL} Conditions: $V_{CC} = 1.6$ to 5.5 V

Parameter		Symbol	Min	Typ	Max	Unit	Test Conditions
Schmitt trigger input voltage	I3C (except for SMBus)*1	V_{IH}	$V_{CC} \times 0.7$	—	5.8	V	—
		V_{IL}	—	—	$V_{CC} \times 0.3$		—
		ΔV_T	$V_{CC} \times 0.10$	—	—		$V_{CC} = 2.7$ to 5.5 V
			$V_{CC} \times 0.05$	—	—		$V_{CC} = 1.6$ to 2.7 V
	RES, NMI Other peripheral input pins excluding I3C	V_{IH}	$V_{CC} \times 0.8$	—	—		—
		V_{IL}	—	—	$V_{CC} \times 0.2$		—
		ΔV_T	$V_{CC} \times 0.10$	—	—		$V_{CC} = 2.7$ to 5.5 V
			$V_{CC} \times 0.05$	—	—		$V_{CC} = 1.6$ to 2.7 V
Input voltage (except for Schmitt trigger input pin)	I3C (SMBus)*2	V_{IH}	2.2	—	—	$V_{CC} = 3.6$ to 5.5 V	
		V_{IH}	2.0	—	—	$V_{CC} = 2.7$ to 3.6 V	
		V_{IL}	—	—	0.8	$V_{CC} = 3.6$ to 5.5 V	
		V_{IL}	—	—	0.5	$V_{CC} = 2.7$ to 3.6 V	
	5V-tolerant ports*3	V_{IH}	$V_{CC} \times 0.8$	—	5.8	—	
		V_{IL}	—	—	$V_{CC} \times 0.2$		
	Input ports pins	V_{IH}	$V_{CC} \times 0.8$	—	—		
		V_{IL}	—	—	$V_{CC} \times 0.2$		

Note 1. SCL0_A, SDA0_A (total 2 pins)

Note 2. SCL0_A, SDA0_A (total 2 pins)

Note 3. P400, P401 (total 2 pins)

2.2.3 I/O I_{OH} , I_{OL} **Table 2.5** I/O I_{OH} , I_{OL} (1 of 2)Conditions: $V_{CC} = 1.6$ to 5.5 V

Parameter		Symbol	Min	Typ	Max	Unit	Test conditions
Permissible output current (max value per pin)	Ports P010, P011, P014, P015	I_{OH}	—	—	-4.0	mA	
		I_{OL}	—	—	8.0	mA	
	Ports P400, P401	I_{OH}	—	—	-8.0	mA	
		I_{OL}	—	—	15.0	mA	
	Other output pins*1	I_{OH}	—	—	-4.0	mA	
		I_{OL}	—	—	20.0	mA	

Table 2.5 I/O I_{OH}, I_{OL} (2 of 2)

Conditions: VCC = 1.6 to 5.5 V

Parameter		Symbol	Min	Typ	Max	Unit	Test conditions
Permissible output current (max value total pins)*1	Total of ports P400, P401	ΣI _{OH} (max)	—	—	-16	mA	VCC = 2.7 to 5.5 V
			—	—	-2		VCC = 1.8 to 2.7 V
			—	—	-1		VCC = 1.6 to 1.8 V
		ΣI _{OL} (max)	—	—	30		VCC = 2.7 to 5.5 V
			—	—	1.2		VCC = 1.8 to 2.7 V
			—	—	0.6		VCC = 1.6 to 1.8 V
	Total of ports P010,P011,P014,P015	ΣI _{OH} (max)	—	—	-16	mA	VCC = 2.7 to 5.5 V
			—	—	-4		VCC = 1.8 to 2.7 V
			—	—	-2		VCC = 1.6 to 1.8 V
		ΣI _{OL} (max)	—	—	32		VCC = 2.7 to 5.5 V
			—	—	2.4		VCC = 1.8 to 2.7 V
			—	—	1.2		VCC = 1.6 to 1.8 V
	Total of other output ports	ΣI _{OH} (max)	—	—	-30	mA	VCC = 2.7 to 5.5 V
			—	—	-12		VCC = 1.8 to 2.7 V
			—	—	-6		VCC = 1.6 to 1.8 V
		ΣI _{OL} (max)	—	—	50		VCC = 2.7 to 5.5 V
			—	—	9		VCC = 1.8 to 2.7 V
			—	—	4.5		VCC = 1.6 to 1.8 V
Total of all output pin	ΣI _{OH} (max)	—	—	-30	mA	—	
	ΣI _{OL} (max)	—	—	80		—	

Note 1. Specification under conditions where the duty factor ≤ 70%.
 The output current value that has changed to the duty factor > 70% the duty ratio can be calculated with the following expression (when changing the duty factor from 70% to n%).
 Total output current of pins = (I_{OH} × 0.7)/(n × 0.01)
 <Example> Where n = 80% and I_{OH} = -30.0 mA
 Total output current of pins = (-30.0 × 0.7)/(80 × 0.01) ≅ -26.2 mA
 However, the current that is allowed to flow into one pin does not vary depending on the duty factor.

Caution: To protect the reliability of the MCU, the output current values should not exceed the values in [Table 2.5](#).

2.2.4 I/O V_{OH}, V_{OL}, and Other Characteristics

Table 2.6 I/O V_{OH}, V_{OL} (1)

Conditions: VCC = 4.0 to 5.5 V

Parameter		Symbol	Min	Typ	Max	Unit	Test conditions
Output voltage	Ports P400, P401	V _{OH}	VCC - 0.27	—	—	V	I _{OH} = -3.0 mA
		V _{OH}	VCC - 0.8	—	—		I _{OH} = -8.0 mA
	Output pins except for P400 and P401*1	V _{OH}	VCC - 0.8	—	—		I _{OH} = -4.0 mA
	Ports P400, P401	V _{OL}	—	—	0.27		I _{OL} = 3.0 mA
		V _{OL}	—	—	0.4		I _{OL} = 9.0 mA
		V _{OL}	—	—	0.8		I _{OL} = 15.0 mA
	P010, P011, P014, P015	V _{OL}	—	—	0.8		I _{OL} = 8.0 mA
	Output pins except for P010, P011, P014, P015, P400 and P401*1	V _{OL}	—	—	1.2		I _{OL} = 20.0 mA

Note 1. Except for Port P200 which is input port.

Table 2.7 I/O V_{OH} , V_{OL} (2)Conditions: $V_{CC} = 2.7$ to 4.0 V

Parameter		Symbol	Min	Typ	Max	Unit	Test conditions
Output voltage	Ports P400, P401	V_{OH}	$V_{CC} - 0.27$	—	—	V	$I_{OH} = -3.0$ mA
		V_{OH}	$V_{CC} - 0.8$	—	—		$I_{OH} = -8.0$ mA
	Output pins except for P400 and P401 ^{*1}	V_{OH}	$V_{CC} - 0.8$	—	—		$I_{OH} = -4.0$ mA
	Ports P400, P401	V_{OL}	—	—	0.27		$I_{OL} = 3.0$ mA
			—	—	0.4		$I_{OL} = 9.0$ mA
			—	—	0.8		$I_{OL} = 15$ mA
Output pins except for P400 and P401 ^{*1}	V_{OL}	—	—	0.8	$I_{OL} = 8.0$ mA		

Note 1. Except for Ports P200, P214, and P215, which are input ports.

Table 2.8 I/O V_{OH} , V_{OL} (3)Conditions: $V_{CC} = 1.6$ to 2.7 V

Parameter		Symbol	Min	Typ	Max	Unit	Test conditions
Output voltage	Output pins ^{*1}	V_{OH}	$V_{CC} - 0.5$	—	—	V	$I_{OH} = -1.0$ mA $V_{CC} = 1.8$ to 2.7 V
			$V_{CC} - 0.5$	—	—		$I_{OH} = -0.5$ mA $V_{CC} = 1.6$ to 1.8 V
	Output pins ^{*1}	V_{OL}	—	—	0.4		$I_{OL} = 0.6$ mA $V_{CC} = 1.8$ to 2.7 V
			—	—	0.4		$I_{OL} = 0.3$ mA $V_{CC} = 1.6$ to 1.8 V

Note 1. Except for Ports P200 which is input port.

Table 2.9 I/O other characteristicsConditions: $V_{CC} = 1.6$ to 5.5 V

Parameter		Symbol	Min	Typ	Max	Unit	Test conditions
Input leakage current	RES, port P200	$ I_{in} $	—	—	1.0	μ A	$V_{in} = 0$ V $V_{in} = V_{CC}$
Three-state leakage current (off state)	5V-tolerant ports ^{*1}	$ I_{TSI} $	—	—	10	μ A	$V_{in} = 0$ V $V_{in} = 5.8$ V
	Other ports (except for P200 and 5V-tolerant ports)		—	—	1.0		$V_{in} = 0$ V $V_{in} = V_{CC}$
Input pull-up resistor	All ports (except for P200)	R_U	10	20	100	k Ω	$V_{in} = 0$ V
Input capacitance	P200	C_{in}	—	—	30	pF	$V_{in} = 0$ V $f = 1$ MHz $T_a = 25^\circ$ C
	Other input pins		—	—	15		

Note 1. P400 and P401 (total 2 pins)

2.2.5 Operating and Standby Current

Table 2.10 Operating and standby current (1) (1 of 2)

Conditions: VCC = 1.6 to 5.5 V

Parameter				Symbol	Typ ^{*10}	Max	Unit	Test Conditions	
Supply current ^{*1}	High-speed mode ^{*2}	Normal mode	All peripheral clocks disabled, CoreMark code executing from flash ^{*5}	ICLK = 48 MHz	3.90	—	mA	*7 *11	
				ICLK = 32 MHz	2.85	—		*7	
				ICLK = 16 MHz	1.75	—			
				ICLK = 8 MHz	1.20	—			
					ICLK = 48 MHz	—		10.5	*9 *11
		Sleep mode	All peripheral clocks disabled ^{*5}	ICLK = 48 MHz	1.00	—		*7	
				ICLK = 32 MHz	0.85	—		*7	
				ICLK = 16 MHz	0.65	—			
	ICLK = 8 MHz			0.60	—				
	All peripheral clocks enabled ^{*5}		ICLK = 48 MHz	3.90	—	*9			
			ICLK = 32 MHz	3.50	—	*8			
				ICLK = 16 MHz	2.00	—			
				ICLK = 8 MHz	1.20	—			
		Increase during BGO operation ^{*6}			2.05	—	—		

Table 2.10 Operating and standby current (1) (2 of 2)

Conditions: VCC = 1.6 to 5.5 V

Parameter					Symbol	Typ ^{*10}	Max	Unit	Test Conditions			
Supply current ^{*1}	Middle-speed mode ^{*2}	Normal mode	All peripheral clocks disabled, CoreMark code executing from flash ^{*5}	ICLK = 24 MHz	I _{CC}	2.15	—	mA	*7			
			ICLK = 4 MHz	0.80		—						
		All peripheral clocks enabled, code executing from flash ^{*5}	ICLK = 24 MHz	—		7.0	*8					
		Sleep mode	All peripheral clocks disabled ^{*5}	ICLK = 24 MHz		0.70	—		*7			
			ICLK = 4 MHz	0.55		—						
			All peripheral clocks enabled ^{*5}	ICLK = 24 MHz		2.70	—		*8			
	ICLK = 4 MHz	0.85	—									
	Increase during BGO operation ^{*6}					1.85	—		—			
	Low-speed mode ^{*3}	Normal mode	All peripheral clocks disabled, CoreMark code executing from flash ^{*5}	ICLK = 2 MHz	I _{CC}	0.30	—	mA	*7			
			ICLK = 2 MHz	—		2.0	*8					
		Sleep mode	All peripheral clocks disabled ^{*5}	ICLK = 2 MHz		0.11	—		*7			
			All peripheral clocks enabled ^{*5}	ICLK = 2 MHz		0.30	—		*8			
		Subosc-speed mode ^{*4}	Normal mode	All peripheral clocks enabled, code executing from flash ^{*5}		ICLK = 32.768 kHz	I _{CC}		—	150	μA	*8
				Sleep mode		All peripheral clocks disabled ^{*5}			ICLK = 32.768 kHz	1.00		—
	All peripheral clocks enabled ^{*5}		ICLK = 32.768 kHz	3.65	—	*8						

Note 1. Supply current is the total current flowing into VCC. Supply current values apply when internal pull-up MOSs are in the off state and these values do not include output charge/discharge current from any of the pins.

Note 2. The clock source is HOCO.

Note 3. The clock source is MOCO.

Note 4. The clock source is LOCO.

Note 5. This does not include BGO operation.

Note 6. This is the increase for programming or erasure of the flash memory for data storage during program execution.

Note 7. PCLKB and PCLKD are set to divided by 64.

Note 8. PCLKB and PCLKD are the same frequency as that of ICLK.

Note 9. PCLKB are set to be divided by 2 and PCLKD is the same frequency as that of ICLK.

Note 10. VCC = 3.3 V.

Note 11. The prefetch buffer is operating.

Table 2.11 Operating and standby current (2)

Conditions: VCC = 1.6 to 5.5 V

Parameter				Symbol	Typ ^{*3}	Max	Unit	Test conditions	
Supply current ^{*1}	Software Standby mode ^{*2}	Peripheral modules stop	All SRAMs (0x2000_4000 to 0x2000_5FFF) are on	T _a = 25°C	I _{CC}	0.2	1.3	μA	—
				T _a = 55°C		0.4	3.7		
				T _a = 85°C		1.35	12		
				T _a = 105°C		3.05	42		
				T _a = 125°C		6.00	85		
			Only 4 KB SRAM (0x2000_4000 to 0x2000_4FFF) is on	T _a = 25°C		0.2	1.3		
				T _a = 55°C		0.4	3.7		
				T _a = 85°C		1.30	12		
				T _a = 105°C		2.85	42		
				T _a = 125°C		5.85	85		

Note 1. Supply current is the total current flowing into VCC. Supply current values apply when internal pull-up MOSs are in the off state and these values do not include output charge/discharge current from any of the pins.

Note 2. The IWDT and LVD are not operating.

Note 3. VCC = 3.3 V.

Table 2.12 Operating and standby current (3)

Conditions: VCC = 1.6 to 5.5 V

Parameter		Symbol	Min	Typ	Max	Unit	Test conditions
Analog power supply current	During 12-bit A/D conversion (at high-speed A/D conversion mode)	I _{VCCAD}	—	—	1.44	mA	—
	During 12-bit A/D conversion (at low-power A/D conversion mode)		—	—	0.78	mA	—
	Waiting for 12-bit A/D conversion (all units) ^{*1}		—	—	1.0	μA	—
Reference power supply current	During 12-bit A/D conversion	I _{REFH0}	—	—	120	μA	—
	Waiting for 12-bit A/D conversion		—	—	60	μA	T _a = 105°C
			—	—	120	μA	T _a = 125°C
Temperature Sensor (TSN) operating current		I _{TNS}	—	95	—	μA	—

Note 1. When the MCU is in Software Standby mode or the MSTPCRD.MSTPD16 (ADC120 module-stop bit) is in the module-stop state.

2.2.6 VCC Rise and Fall Gradient and Ripple Frequency

Table 2.13 Rise and fall gradient characteristics

Conditions: VCC = 0 to 5.5 V

Parameter		Symbol	Min	Typ	Max	Unit	Test conditions
Power-on VCC rising gradient	Voltage monitor 0 reset disabled at startup	SrVCC	0.02	—	2	ms/V	—
	Voltage monitor 0 reset enabled at startup ^{*1 *2}				—		
	SCI boot mode ^{*2}				2		

Note 1. When OFS1.LVDAS = 0.

Note 2. At boot mode, the reset from voltage monitor 0 is disabled regardless of the value of OFS1.LVDAS bit.

Table 2.14 Rising and falling gradient and ripple frequency characteristics

Conditions: VCC = 1.6 to 5.5 V

The ripple voltage must meet the allowable ripple frequency $f_{r(VCC)}$ within the range between the VCC upper limit (5.5 V) and lower limit (1.6 V).

When the VCC change exceeds $VCC \pm 10\%$, the allowable voltage change rising and falling gradient $dt/dVCC$ must be met.

Parameter	Symbol	Min	Typ	Max	Unit	Test conditions
Allowable ripple frequency	$f_{r(VCC)}$	—	—	10	kHz	Figure 2.2 $V_r(VCC) \leq VCC \times 0.2$
		—	—	1	MHz	Figure 2.2 $V_r(VCC) \leq VCC \times 0.08$
		—	—	10	MHz	Figure 2.2 $V_r(VCC) \leq VCC \times 0.06$
Allowable voltage change rising and falling gradient	$dt/dVCC$	1.0	—	—	ms/V	When VCC change exceeds $VCC \pm 10\%$

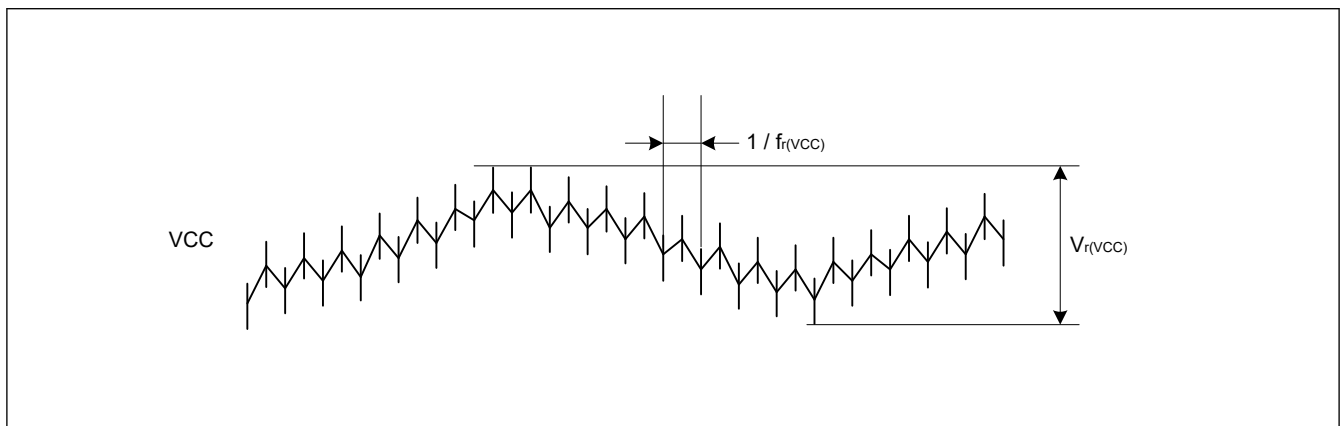

Figure 2.2 Ripple waveform

2.3 AC Characteristics

2.3.1 Frequency

Table 2.15 Operation frequency in high-speed operating mode

Conditions: VCC = 1.8 to 5.5 V

Parameter	Symbol	Min	Typ	Max ^{*4}	Unit
Operation frequency	System clock (ICLK) ^{*1*2}	1.8 to 5.5 V	f	0.032768	MHz
	Peripheral module clock (PCLKB)	1.8 to 5.5 V	—	—	
	Peripheral module clock (PCLKD) ^{*3}	1.8 to 5.5 V	—	—	

Note 1. The lower-limit frequency of ICLK is 1 MHz while programming or erasing the flash memory. When using ICLK for programming or erasing the flash memory at below 4 MHz, the frequency can be set to 1 MHz, 2 MHz, or 3 MHz. A non-integer frequency such as 1.5 MHz cannot be set.

Note 2. The frequency accuracy of ICLK must be $\pm 1.0\%$ during programming or erasing the flash memory. Confirm the frequency accuracy of the clock source.

Note 3. The lower-limit frequency of PCLKD is 1 MHz when the ADC12 is in use.

Note 4. The maximum value of operation frequency does not include internal oscillator errors. For details on the range for guaranteed operation, see Table 2.19.

Table 2.16 Operation frequency in middle-speed mode

Conditions: VCC = 1.6 to 5.5 V

Parameter			Symbol	Min	Typ	Max ⁴	Unit
Operation frequency	System clock (ICLK) ^{*1*2}	1.8 to 5.5 V	f	0.032768	—	24	MHz
		1.6 to 1.8 V		0.032768	—	4	
	Peripheral module clock (PCLKB)	1.8 to 5.5 V		—	—	24	
		1.6 to 1.8 V		—	—	4	
	Peripheral module clock (PCLKD) ^{*3}	1.8 to 5.5 V		—	—	24	
		1.6 to 1.8 V		—	—	4	

Note 1. The lower-limit frequency of ICLK is 1 MHz while programming or erasing the flash memory. When using ICLK for programming or erasing the flash memory at below 4 MHz, the frequency can be set to 1 MHz, 2 MHz, or 3 MHz. A non-integer frequency such as 1.5 MHz cannot be set.

Note 2. The frequency accuracy of ICLK must be $\pm 1.0\%$ while programming or erasing the flash memory. Confirm the frequency accuracy of the clock source.

Note 3. The lower-limit frequency of PCLKD is 1 MHz when the ADC12 is in use.

Note 4. The maximum value of operation frequency does not include internal oscillator errors. For details on the range for guaranteed operation, see [Table 2.19](#).

Table 2.17 Operation frequency in low-speed mode

Conditions: VCC = 1.6 to 5.5 V

Parameter			Symbol	Min	Typ	Max ⁴	Unit
Operation frequency	System clock (ICLK) ^{*1*2}	1.6 to 5.5 V	f	0.032768	—	2	MHz
	Peripheral module clock (PCLKB)	1.6 to 5.5 V		—	—	2	
	Peripheral module clock (PCLKD) ^{*3}	1.6 to 5.5 V		—	—	2	

Note 1. The lower-limit frequency of ICLK is 1 MHz while programming or erasing the flash memory.

Note 2. The frequency accuracy of ICLK must be $\pm 1.0\%$ while programming or erasing the flash memory. Confirm the frequency accuracy of the clock source.

Note 3. The lower-limit frequency of PCLKD is 1 MHz when the ADC12 is in use.

Note 4. The maximum value of operation frequency does not include internal oscillator errors. For details on the range for guaranteed operation, see [Table 2.19](#).

Table 2.18 Operation frequency in Subosc-speed mode

Conditions: VCC = 1.6 to 5.5 V

Parameter			Symbol	Min	Typ	Max	Unit
Operation frequency	System clock (ICLK) ^{*1}	1.6 to 5.5 V	f	27.8528	32.768	37.6832	kHz
	Peripheral module clock (PCLKB)	1.6 to 5.5 V		—	—	37.6832	
	Peripheral module clock (PCLKD) ^{*2}	1.6 to 5.5 V		—	—	37.6832	

Note 1. Programming and erasing the flash memory is not possible.

Note 2. The ADC12 cannot be used.

2.3.2 Clock Timing

Table 2.19 Clock timing (1 of 2)

Parameter	Symbol	Min	Typ	Max	Unit	Test conditions
LOCO clock oscillation frequency	f _{LOCO}	27.8528	32.768	37.6832	kHz	—
LOCO clock oscillation stabilization time	t _{LOCO}	—	—	100	μs	Figure 2.3
IWDT-dedicated clock oscillation frequency	f _{ILOCO}	12.75	15	17.25	kHz	—
MOCO clock oscillation frequency	f _{MOCO}	6.8	8	9.2	MHz	—
MOCO clock oscillation stabilization time	t _{MOCO}	—	—	1	μs	—

Table 2.19 Clock timing (2 of 2)

Parameter	Symbol	Min	Typ	Max	Unit	Test conditions
HOCO clock oscillation frequency ^{*3}	f _{HOCO24}	23.76	24	24.24	MHz	Ta = -40 to 125°C 1.6 ≤ VCC ≤ 5.5
	f _{HOCO32}	31.68	32	32.32		Ta = -40 to 125°C 1.6 ≤ VCC ≤ 5.5
	f _{HOCO48}	47.52	48	48.48		Ta = -40 to 125°C 1.6 ≤ VCC ≤ 5.5
	f _{HOCO64}	63.36	64	64.64		Ta = -40 to 125°C 1.6 ≤ VCC ≤ 5.5
HOCO clock oscillation stabilization time ^{*1 *2}	t _{HOCO24} t _{HOCO32} t _{HOCO48} t _{HOCO64}	—	6.7	7.7	μs	Figure 2.4

Note 1. This is a characteristic when the HOCOCR.HCSTP bit is set to 0 (oscillation) in the MOCO stop state. When the HOCOCR.HCSTP bit is set to 0 (oscillation) during MOCO oscillation, this specification is shortened by 1 μs.
 Note 2. Check OSCSF.HOCOSF to confirm whether stabilization time has elapsed.
 Note 3. Accuracy at production test.

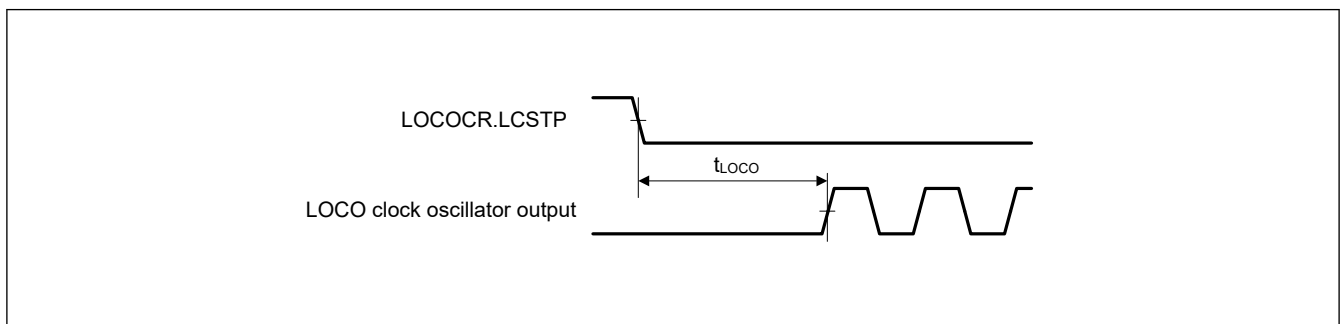

Figure 2.3 LOCO clock oscillation start timing

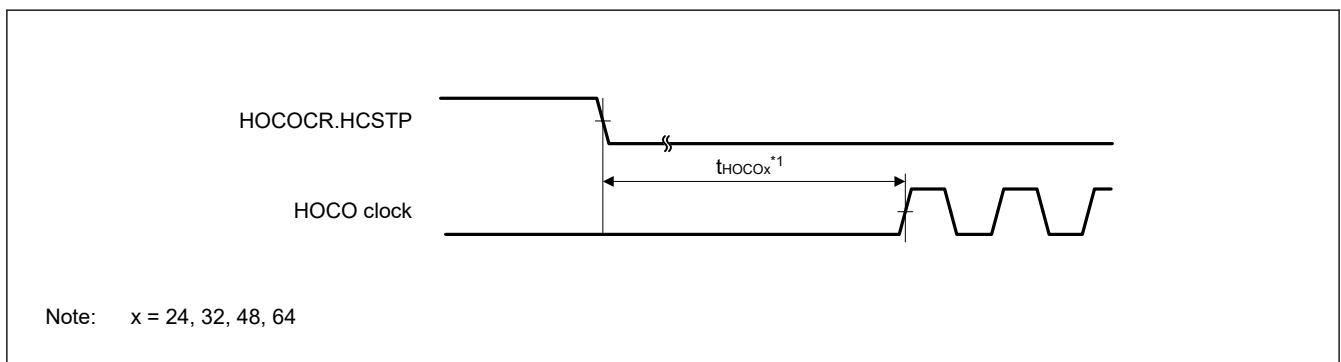

Figure 2.4 HOCO clock oscillation start timing (started by setting the HOCOCR.HCSTP bit)

2.3.3 Reset Timing

Table 2.20 Reset timing (1 of 2)

Parameter		Symbol	Min	Typ	Max	Unit	Test conditions
RES pulse width	At power-on	t _{RESWP}	10	—	—	ms	Figure 2.5
	Not at power-on	t _{RESW}	30	—	—	μs	Figure 2.6
Wait time after RES cancellation (at power-on)	LVD0 enabled ^{*1}	t _{RESWT}	—	0.9	—	ms	Figure 2.5
	LVD0 disabled ^{*2}		—	0.2	—		

Table 2.20 Reset timing (2 of 2)

Parameter		Symbol	Min	Typ	Max	Unit	Test conditions
Wait time after RES cancellation (during powered-on state)	LVD0 enabled*1	t_{RESWT2}	—	0.9	—	ms	Figure 2.6
	LVD0 disabled*2		—	0.2	—		
Wait time after internal reset cancellation (Watchdog timer reset, SRAM parity error reset, bus master MPU error reset, bus slave MPU error reset, stack pointer error reset, software reset)	LVD0 enabled*1	t_{RESWT3}	—	0.9	—	ms	Figure 2.7
	LVD0 disabled*2		—	0.15	—		

Note 1. When OFS1.LVDAS = 0.
 Note 2. When OFS1.LVDAS = 1.

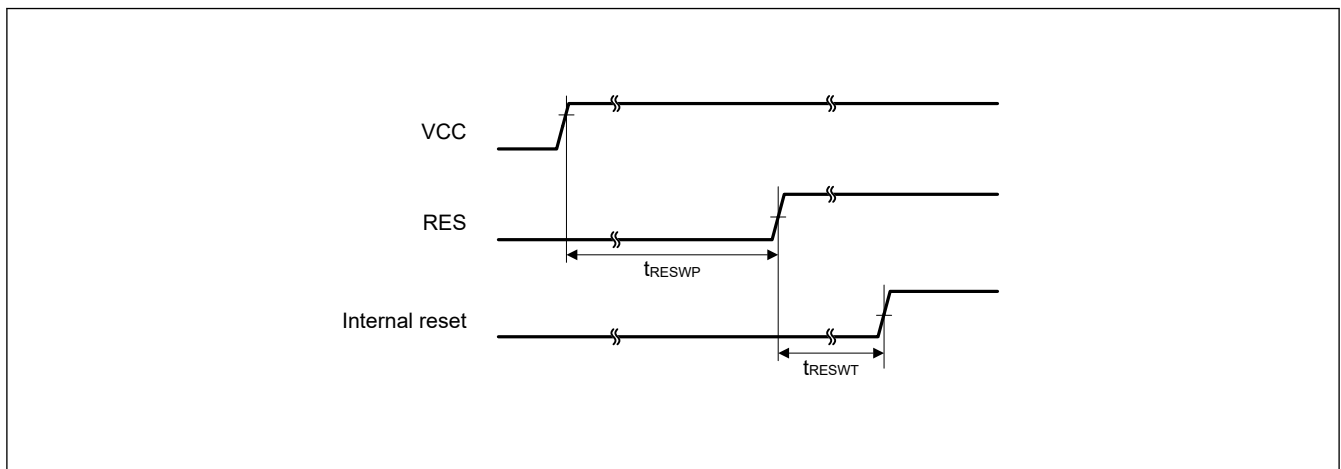

Figure 2.5 Reset input timing at power-on

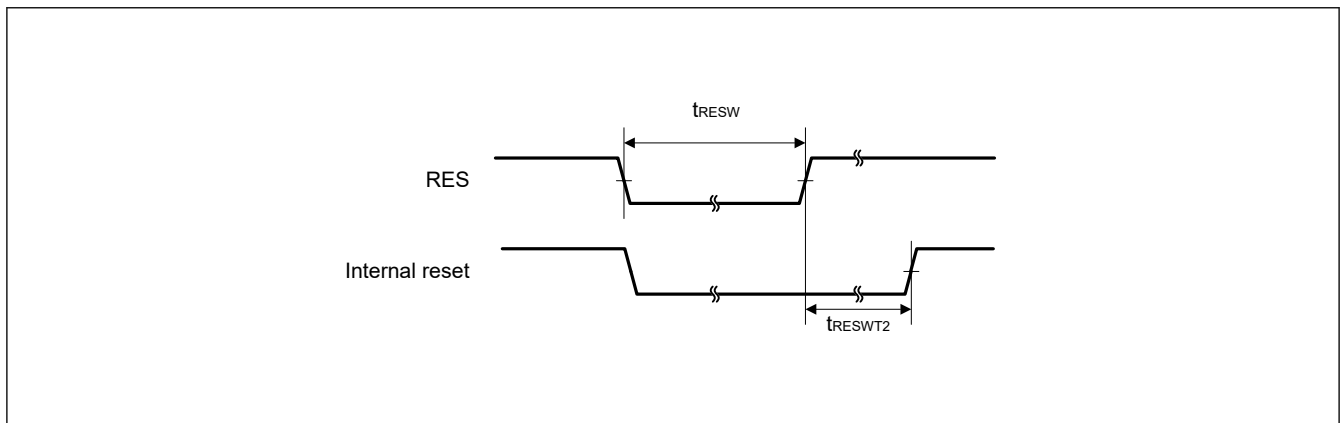

Figure 2.6 Reset input timing (1)

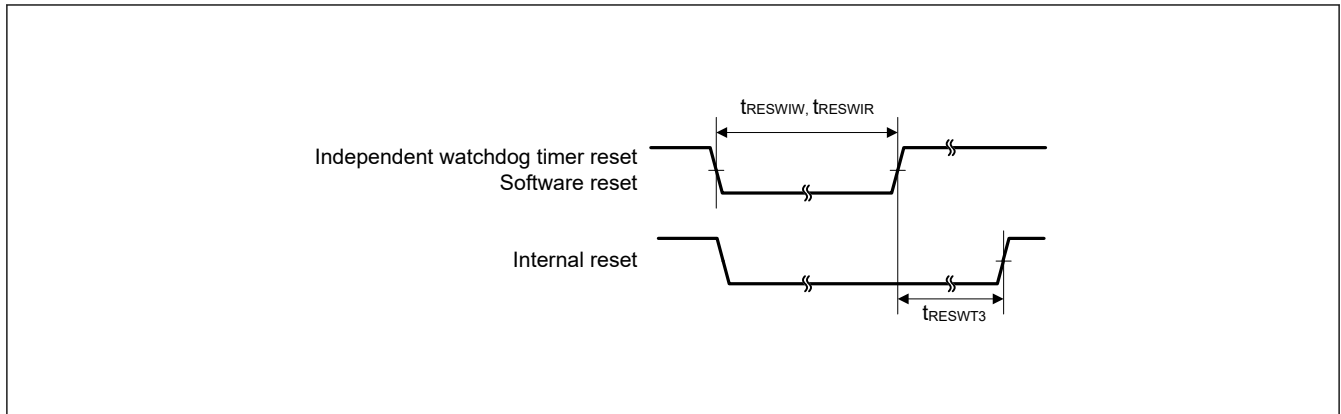

Figure 2.7 Reset input timing (2)

2.3.4 Wakeup Time

Table 2.21 Timing of recovery from low power modes (1)

Parameter	Symbol	Min	Typ	Max	Unit	Test conditions	
Recovery time from Software Standby mode ^{*1}	High-speed mode					Figure 2.8	
	System clock source is HOCO (HOCO clock is 32 MHz) ^{*2}	t_{SBYHO}	—	7.4	9.1		μs
	System clock source is HOCO (HOCO clock is 48 MHz) ^{*3}	t_{SBYHO}	—	7.3	8.9		μs
	System clock source is HOCO (HOCO clock is 64 MHz) ^{*2}	t_{SBYHO}	—	7.4	9.1		μs
System clock source is MOCO (8 MHz)	t_{SBYMO}	—	4	5	μs		

Note 1. The division ratio of ICLK and PCLKx is the minimum division ratio within the allowable frequency range. The recovery time is determined by the system clock source.

Note 2. The system clock is 32 MHz.

Note 3. The system clock is 48 MHz.

Table 2.22 Timing of recovery from low power modes (2)

Parameter	Symbol	Min	Typ	Max	Unit	Test conditions	
Recovery time from Software Standby mode ^{*1}	Middle-speed mode					Figure 2.8	
	System clock source is HOCO ^{*2}	t_{SBYHO}	—	7.7	9.4		μs
	VCC = 1.8 V to 5.5 V						
	VCC = 1.6 V to 1.8 V		—	15.7	17.9		
System clock source is MOCO (8 MHz)	t_{SBYMO}	—	4	5	μs		
VCC = 1.8 V to 5.5 V							
VCC = 1.6 V to 1.8 V		—	7.2	9			

Note 1. The division ratio of ICLK and PCLKx is the minimum division ratio within the allowable frequency range. The recovery time is determined by the system clock source.

Note 2. The system clock is 24 MHz.

Table 2.23 Timing of recovery from low power modes (3)

Parameter			Symbol	Min	Typ	Max	Unit	Test conditions
Recovery time from Software Standby mode ^{*1}	Low-speed mode	System clock source is MOCO (2 MHz)	t_{SBYMO}	—	12	15	μs	Figure 2.8

Note 1. The division ratio of ICLK and PCLKx is the minimum division ratio within the allowable frequency range. The recovery time is determined by the system clock source.

Table 2.24 Timing of recovery from low power modes (4)

Parameter			Symbol	Min	Typ	Max	Unit	Test conditions
Recovery time from Software Standby mode	Subosc-speed mode	System clock source is LOCO (32.768 kHz)	t_{SBYLO}	—	0.85	1.2	ms	Figure 2.8

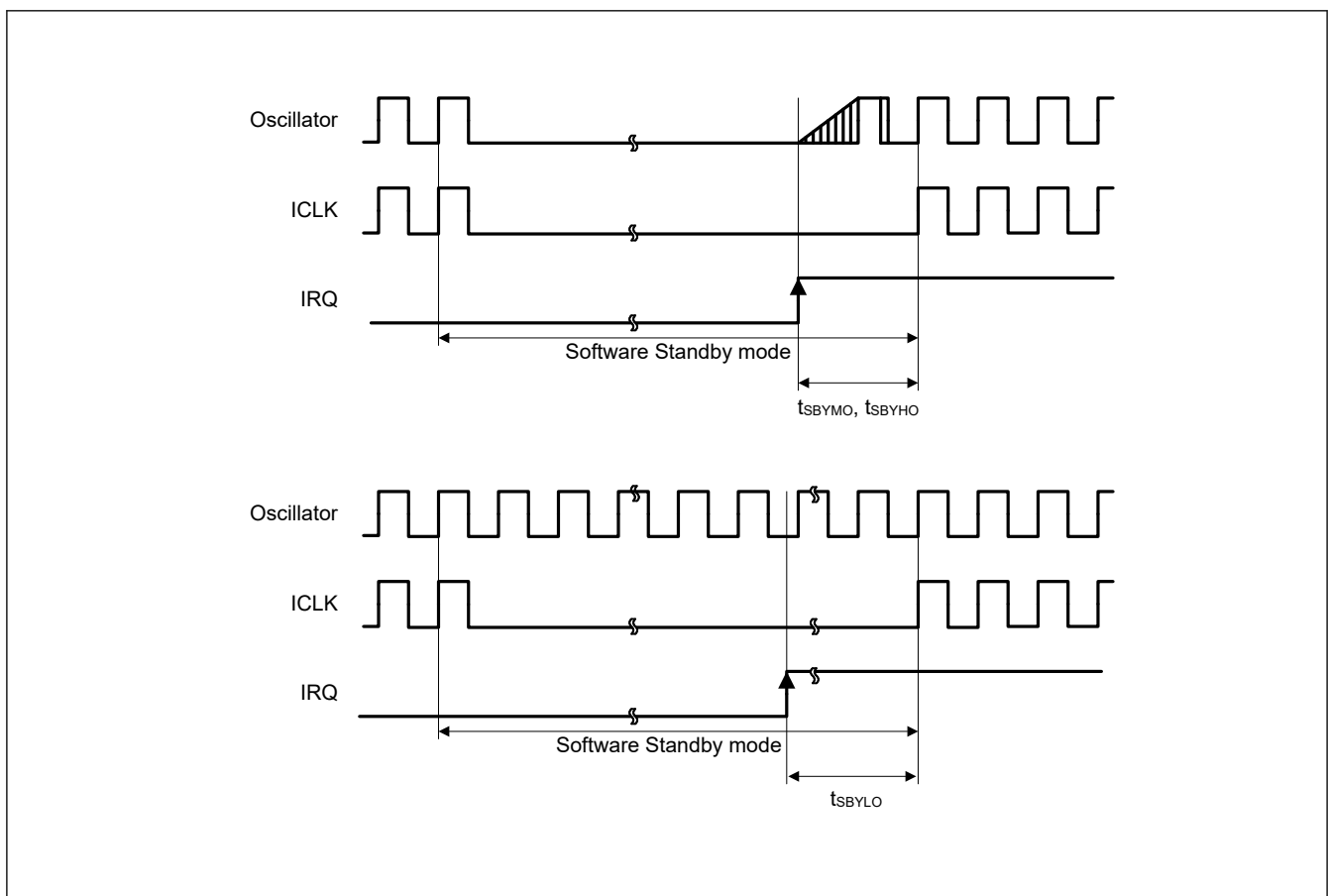

Figure 2.8 Software Standby mode cancellation timing

Table 2.25 Timing of recovery from low power modes (5) (1 of 2)

Parameter		Symbol	Min	Typ	Max	Unit	Test conditions
Recovery time from Software Standby mode to Snooze mode	High-speed mode System clock source is HOCO	t_{SNZ}	—	6.6	8.1	μs	Figure 2.9
	Middle-speed mode System clock source is HOCO (24 MHz) VCC = 1.8 V to 5.5 V	t_{SNZ}	—	6.7	8.2	μs	

Table 2.25 Timing of recovery from low power modes (5) (2 of 2)

Parameter	Symbol	Min	Typ	Max	Unit	Test conditions
Middle-speed mode System clock source is HOCO (24 MHz) VCC = 1.6 V to 1.8 V	t_{SNZ}	—	10.8	12.9	μs	
Low-speed mode System clock source is MOCO (2 MHz)	t_{SNZ}	—	6.7	8.0	μs	

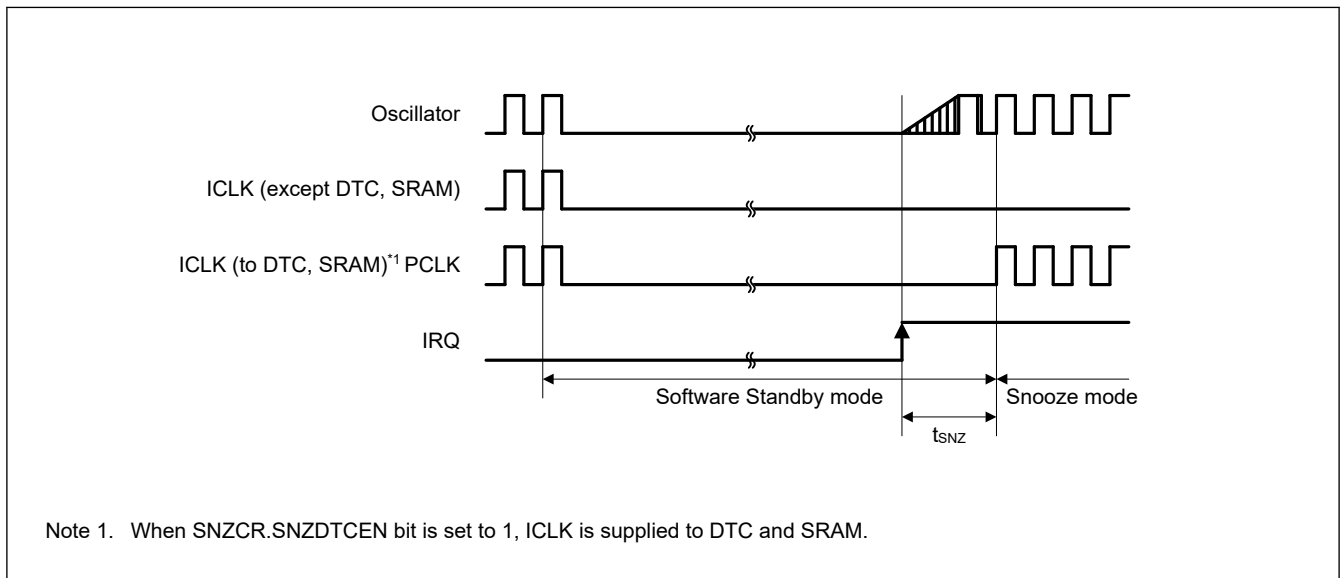

Figure 2.9 Recovery timing from Software Standby mode to Snooze mode

2.3.5 NMI and IRQ Noise Filter

Table 2.26 NMI and IRQ noise filter

Parameter	Symbol	Min	Typ	Max	Unit	Test conditions	
NMI pulse width	t_{NMIW}	200	—	—	ns	NMI digital filter disabled	$t_{Pcyc} \times 2 \leq 200$ ns
		$t_{Pcyc} \times 2^{*1}$	—	—			$t_{Pcyc} \times 2 > 200$ ns
		200	—	—		NMI digital filter enabled	$t_{NMICK} \times 3 \leq 200$ ns
		$t_{NMICK} \times 3.5^{*2}$	—	—			$t_{NMICK} \times 3 > 200$ ns
IRQ pulse width	t_{IRQW}	200	—	—	ns	IRQ digital filter disabled	$t_{Pcyc} \times 2 \leq 200$ ns
		$t_{Pcyc} \times 2^{*1}$	—	—			$t_{Pcyc} \times 2 > 200$ ns
		200	—	—		IRQ digital filter enabled	$t_{IRQCK} \times 3 \leq 200$ ns
		$t_{IRQCK} \times 3.5^{*3}$	—	—			$t_{IRQCK} \times 3 > 200$ ns

- Note: 200 ns minimum in Software Standby mode.
- Note: If the clock source is being switched it is needed to add 4 clock cycle of switched source.
- Note 1. t_{Pcyc} indicates the PCLKB cycle.
- Note 2. t_{NMICK} indicates the cycle of the NMI digital filter sampling clock.
- Note 3. t_{IRQCK} indicates the cycle of the IRQi digital filter sampling clock (i = 0 to 7).

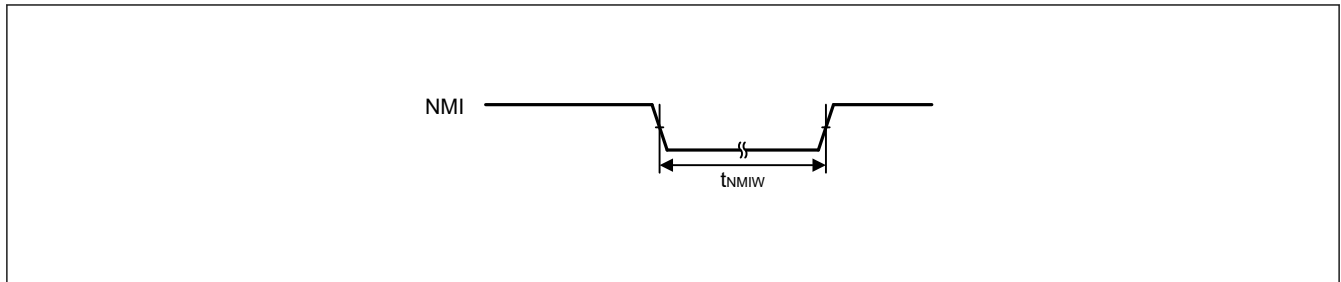

Figure 2.10 NMI interrupt input timing

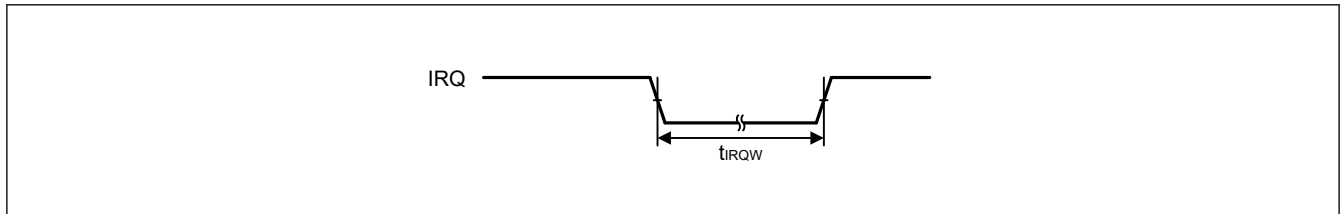

Figure 2.11 IRQ interrupt input timing

2.3.6 I/O Ports, POEG, GPT, AGTW, KINT, and ADC12 Trigger Timing

Table 2.27 I/O Ports, POEG, GPT, AGTW, KINT, and ADC12 trigger timing

Parameter		Symbol	Min	Max	Unit	Test conditions	
I/O Ports	Input data pulse width	$2.7\text{ V} \leq V_{CC} \leq 5.5\text{ V}$	t_{PRW}	2	—	t_{Pcyc}	Figure 2.12
		$2.4\text{ V} \leq V_{CC} < 2.7\text{ V}$		3			
		$1.6\text{ V} \leq V_{CC} < 2.4\text{ V}$		4			
POEG	POEG input trigger pulse width	t_{POEW}	3	—	t_{Pcyc}	Figure 2.13	
GPT	Input capture pulse width	Single edge	t_{GTICW}	1.5	—	t_{PDcyc}	Figure 2.14
		Dual edge		2.5	—		
AGTW	AGTIO, AGTEE input cycle	$1.8\text{ V} \leq V_{CC} \leq 5.5\text{ V}$	t_{ACYC}^{*1}	250	—	ns	Figure 2.15
		$1.6\text{ V} \leq V_{CC} < 1.8\text{ V}$		2000	—	ns	
	AGTIO, AGTEE input high-level width, low-level width	$1.8\text{ V} \leq V_{CC} \leq 5.5\text{ V}$	t_{ACKWH}	100	—	ns	
		$1.6\text{ V} \leq V_{CC} < 1.8\text{ V}$	t_{ACKWL}	800	—	ns	
	AGTIO, AGTO, AGTOA, AGTOB output cycle	$2.7\text{ V} \leq V_{CC} \leq 5.5\text{ V}$	t_{ACYC2}	62.5	—	ns	
		$2.4\text{ V} \leq V_{CC} < 2.7\text{ V}$		125	—	ns	
$1.8\text{ V} \leq V_{CC} < 2.4\text{ V}$			250	—	ns		
$1.6\text{ V} \leq V_{CC} < 1.8\text{ V}$			500	—	ns		
ADC12	12-bit A/D converter trigger input pulse width	t_{TRGW}	1.5	—	t_{Pcyc}	Figure 2.16	
KINT	KRn (n = 00 to 03) pulse width	t_{KR}	250	—	ns	Figure 2.17	

Note 1. Constraints on AGTIO input: $t_{Pcyc} \times 2 (t_{Pcyc}: \text{PCLKB cycle}) < t_{ACYC}$.

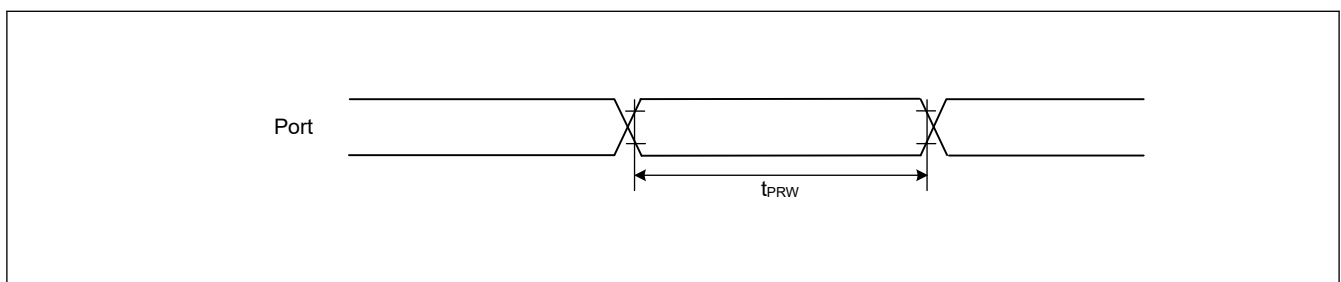

Figure 2.12 I/O ports input timing



Figure 2.13 POEG input trigger timing



Figure 2.14 GPT input capture timing



Figure 2.15 AGTW I/O timing



Figure 2.16 ADC12 trigger input timing

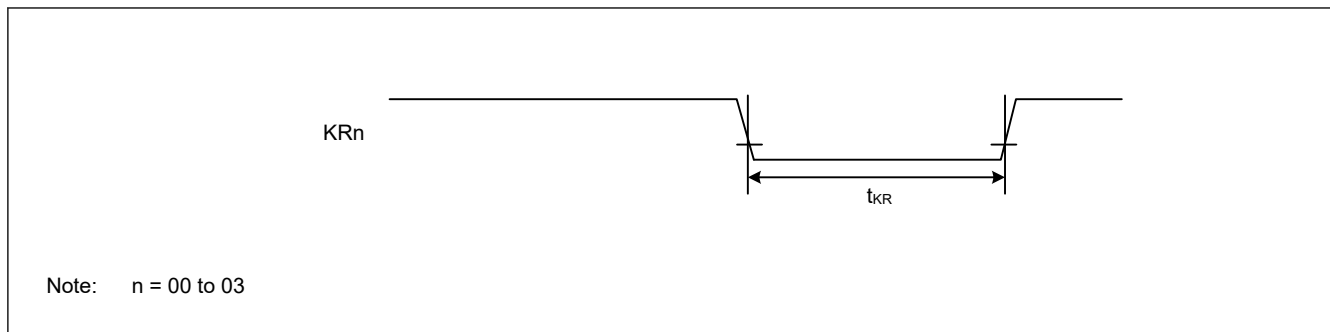

Figure 2.17 Key interrupt input timing

2.3.7 CAC Timing

Table 2.28 CAC timing

Conditions: VCC = 1.6 to 5.5 V

Parameter		Symbol	Min	Typ	Max	Unit	Test conditions
CAC	CACREF input pulse width	t _{CACREF}	t _{Pcyc} ^{*1} ≤ t _{CAC} ^{*2}	—	—	ns	—
			t _{Pcyc} ^{*1} > t _{CAC} ^{*2}	4.5 × t _{CAC} + 3 × t _{Pcyc}	—	—	

Note 1. t_{Pcyc}: PCLKB cycle.

Note 2. t_{CAC}: CAC count clock source cycle.

2.3.8 SCI Timing

Table 2.29 SCI timing (1)

Conditions: VCC = 1.6 to 5.5 V

Parameter			Symbol	Min	Max	Unit	Test conditions	
SCI	Input clock cycle	Asynchronous	$2.7\text{ V} \leq \text{VCC} \leq 5.5\text{ V}$	t_{Scyc}	125	—	ns	Figure 2.18
			$2.4\text{ V} \leq \text{VCC} < 2.7\text{ V}$		250	—		
			$1.8\text{ V} \leq \text{VCC} < 2.4\text{ V}$		500	—		
			$1.6\text{ V} \leq \text{VCC} < 1.8\text{ V}$		1000	—		
		Clock synchronous	$2.7\text{ V} \leq \text{VCC} \leq 5.5\text{ V}$		187.5	—		
			$2.4\text{ V} \leq \text{VCC} < 2.7\text{ V}$		375	—		
			$1.8\text{ V} \leq \text{VCC} < 2.4\text{ V}$		750	—		
			$1.6\text{ V} \leq \text{VCC} < 1.8\text{ V}$		1500	—		
	Input clock pulse width			t_{SCKW}	0.4	0.6	t_{Scyc}	
	Input clock rise time			t_{SCKr}	—	20	ns	
	Input clock fall time			t_{SCKf}	—	20	ns	
	Output clock cycle	Asynchronous	$2.7\text{ V} \leq \text{VCC} \leq 5.5\text{ V}$	t_{Scyc}	187.5	—	ns	
			$2.4\text{ V} \leq \text{VCC} < 2.7\text{ V}$		375	—		
			$1.8\text{ V} \leq \text{VCC} < 2.4\text{ V}$		750	—		
			$1.6\text{ V} \leq \text{VCC} < 1.8\text{ V}$		1500	—		
		Clock synchronous	$2.7\text{ V} \leq \text{VCC} \leq 5.5\text{ V}$		125	—		
$2.4\text{ V} \leq \text{VCC} < 2.7\text{ V}$			250		—			
$1.8\text{ V} \leq \text{VCC} < 2.4\text{ V}$			500		—			
$1.6\text{ V} \leq \text{VCC} < 1.8\text{ V}$			1000		—			
Output clock pulse width			t_{SCKW}	0.4	0.6	t_{Scyc}		
Output clock rise time	$1.8\text{ V} \leq \text{VCC} \leq 5.5\text{ V}$		t_{SCKr}	—	20	ns		
	$1.6\text{ V} \leq \text{VCC} < 1.8\text{ V}$			—	30			
Output clock fall time	$1.8\text{ V} \leq \text{VCC} \leq 5.5\text{ V}$		t_{SCKf}	—	20	ns		
	$1.6\text{ V} \leq \text{VCC} < 1.8\text{ V}$			—	30			
Transmit data delay time (master)	Clock synchronous	$1.8\text{ V} \leq \text{VCC} \leq 5.5\text{ V}$	t_{TXD}	—	40	ns	Figure 2.19	
		$1.6\text{ V} \leq \text{VCC} < 1.8\text{ V}$		—	45			
Transmit data delay time (slave)	Clock synchronous	$2.7\text{ V} \leq \text{VCC} \leq 5.5\text{ V}$	t_{TXD}	—	55	ns		
		$2.4\text{ V} \leq \text{VCC} < 2.7\text{ V}$		—	60			
		$1.8\text{ V} \leq \text{VCC} < 2.4\text{ V}$		—	100			
		$1.6\text{ V} \leq \text{VCC} < 1.8\text{ V}$		—	125			
Receive data setup time (master)	Clock synchronous	$2.7\text{ V} \leq \text{VCC} \leq 5.5\text{ V}$	t_{RXS}	45	—	ns		
		$2.4\text{ V} \leq \text{VCC} < 2.7\text{ V}$		55	—			
		$1.8\text{ V} \leq \text{VCC} < 2.4\text{ V}$		90	—			
		$1.6\text{ V} \leq \text{VCC} < 1.8\text{ V}$		110	—			
Receive data setup time (slave)	Clock synchronous	$2.7\text{ V} \leq \text{VCC} \leq 5.5\text{ V}$	t_{RXS}	40	—	ns		
		$1.6\text{ V} \leq \text{VCC} < 2.7\text{ V}$		45	—			
Receive data hold time (master)	Clock synchronous		t_{RXH}	5	—	ns		
Receive data hold time (slave)	Clock synchronous		t_{RXH}	40	—	ns		

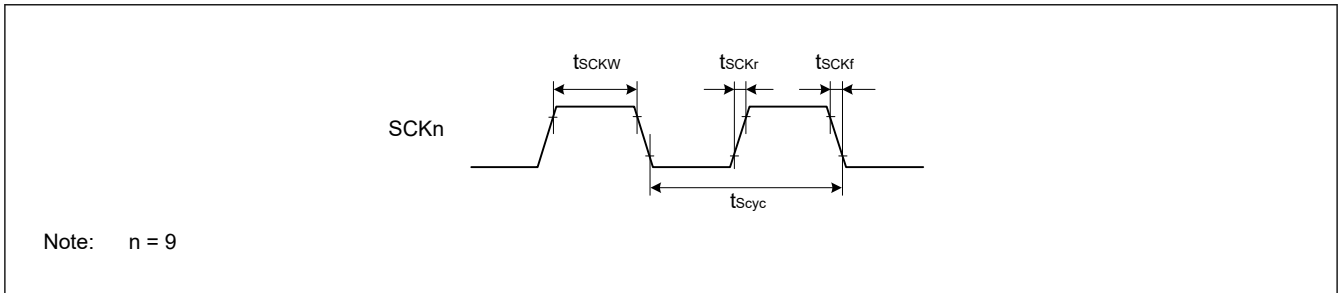

Figure 2.18 SCK clock input timing

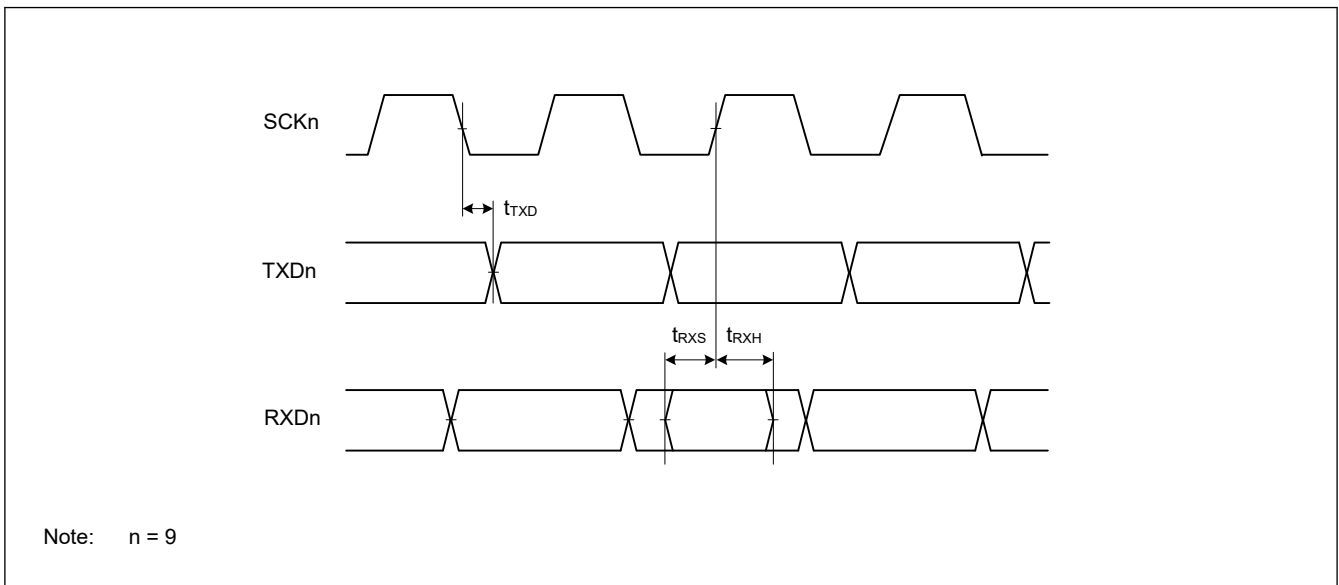

Figure 2.19 SCI input/output timing in clock synchronous mode

Table 2.30 SCI timing (2) (1 of 2)

Conditions: VCC = 1.6 to 5.5 V

Parameter			Symbol	Min	Max	Unit*1	Test conditions			
Simple SPI	SCK clock cycle output (master)	$2.7\text{ V} \leq \text{VCC} \leq 5.5\text{ V}$	t_{SPcyc}	125	—	ns	Figure 2.20			
		$2.4\text{ V} \leq \text{VCC} < 2.7\text{ V}$		250	—					
		$1.8\text{ V} \leq \text{VCC} < 2.4\text{ V}$		500	—					
		$1.6\text{ V} \leq \text{VCC} < 1.8\text{ V}$		1000	—					
	SCK clock cycle input (slave)	$2.7\text{ V} \leq \text{VCC} \leq 5.5\text{ V}$		187.5	—					
		$2.4\text{ V} \leq \text{VCC} < 2.7\text{ V}$		375	—					
		$1.8\text{ V} \leq \text{VCC} < 2.4\text{ V}$		750	—					
		$1.6\text{ V} \leq \text{VCC} < 1.8\text{ V}$		1500	—					
	SCK clock high pulse width			t_{SPCKWH}	0.4			0.6	t_{SPcyc}	
	SCK clock low pulse width			t_{SPCKWL}	0.4			0.6	t_{SPcyc}	
SCK clock rise and fall time	$1.8\text{ V} \leq \text{VCC} \leq 5.5\text{ V}$	t_{SPCKr} t_{SPCKf}	—	20	ns					
	$1.6\text{ V} \leq \text{VCC} < 1.8\text{ V}$		—	30						
Data input setup time	Master	$2.7\text{ V} \leq \text{VCC} \leq 5.5\text{ V}$	t_{SU}	45	—	ns	Figure 2.21 to Figure 2.24			
		$2.4\text{ V} \leq \text{VCC} < 2.7\text{ V}$		55	—					
		$1.8\text{ V} \leq \text{VCC} < 2.4\text{ V}$		80	—					
		$1.6\text{ V} \leq \text{VCC} < 1.8\text{ V}$		110	—					
	Slave	$2.7\text{ V} \leq \text{VCC} \leq 5.5\text{ V}$		40	—					
		$1.6\text{ V} \leq \text{VCC} < 2.7\text{ V}$		45	—					
Data input hold time	Master		t_{H}	33.3	—	ns				
	Slave			40	—					
SS input setup time		t_{LEAD}	1	—	t_{SPcyc}					
SS input hold time		t_{LAG}	1	—	t_{SPcyc}					
Data output delay time	Master	$1.8\text{ V} \leq \text{VCC} \leq 5.5\text{ V}$	t_{OD}	—	40	ns				
		$1.6\text{ V} \leq \text{VCC} < 1.8\text{ V}$		—	50					
	Slave	$2.4\text{ V} \leq \text{VCC} \leq 5.5\text{ V}$		—	65					
		$1.8\text{ V} \leq \text{VCC} < 2.4\text{ V}$		—	100					
		$1.6\text{ V} \leq \text{VCC} < 1.8\text{ V}$		—	125					
Data output hold time	Master	$2.7\text{ V} \leq \text{VCC} \leq 5.5\text{ V}$	t_{OH}	-10	—	ns				
		$2.4\text{ V} \leq \text{VCC} < 2.7\text{ V}$		-20	—					
		$1.8\text{ V} \leq \text{VCC} < 2.4\text{ V}$		-30	—					
		$1.6\text{ V} \leq \text{VCC} < 1.8\text{ V}$		-40	—					
	Slave				-10			—		
	Data rise and fall time	Master		$1.8\text{ V} \leq \text{VCC} \leq 5.5\text{ V}$	$t_{\text{Dr}}, t_{\text{Df}}$			—	20	ns
$1.6\text{ V} \leq \text{VCC} < 1.8\text{ V}$			—	30						
Slave		$1.8\text{ V} \leq \text{VCC} \leq 5.5\text{ V}$	—	20						
		$1.6\text{ V} \leq \text{VCC} < 1.8\text{ V}$	—	30						

Table 2.30 SCI timing (2) (2 of 2)

Conditions: VCC = 1.6 to 5.5 V

Parameter		Symbol	Min	Max	Unit*1	Test conditions	
Simple SPI	Slave access time	2.4 V ≤ VCC ≤ 5.5 V	—	6	t _{Pcyc}	Figure 2.24	
		1.8 V ≤ VCC < 2.4 V	24 MHz ≤ PCLKB ≤ 32 MHz	—			7
			PCLKB < 24 MHz	—			6
		1.6 V ≤ VCC < 1.8 V	—	6			
	Slave output release time	2.4 V ≤ VCC ≤ 5.5 V	t _{REL}	—	6		t _{Pcyc}
		1.8 V ≤ VCC < 2.4 V	24 MHz ≤ PCLKB ≤ 32 MHz	—	7		
			PCLKB < 24 MHz	—	6		
		1.6 V ≤ VCC < 1.8 V	—	6			

Note 1. t_{Pcyc}: PCLKB cycle.

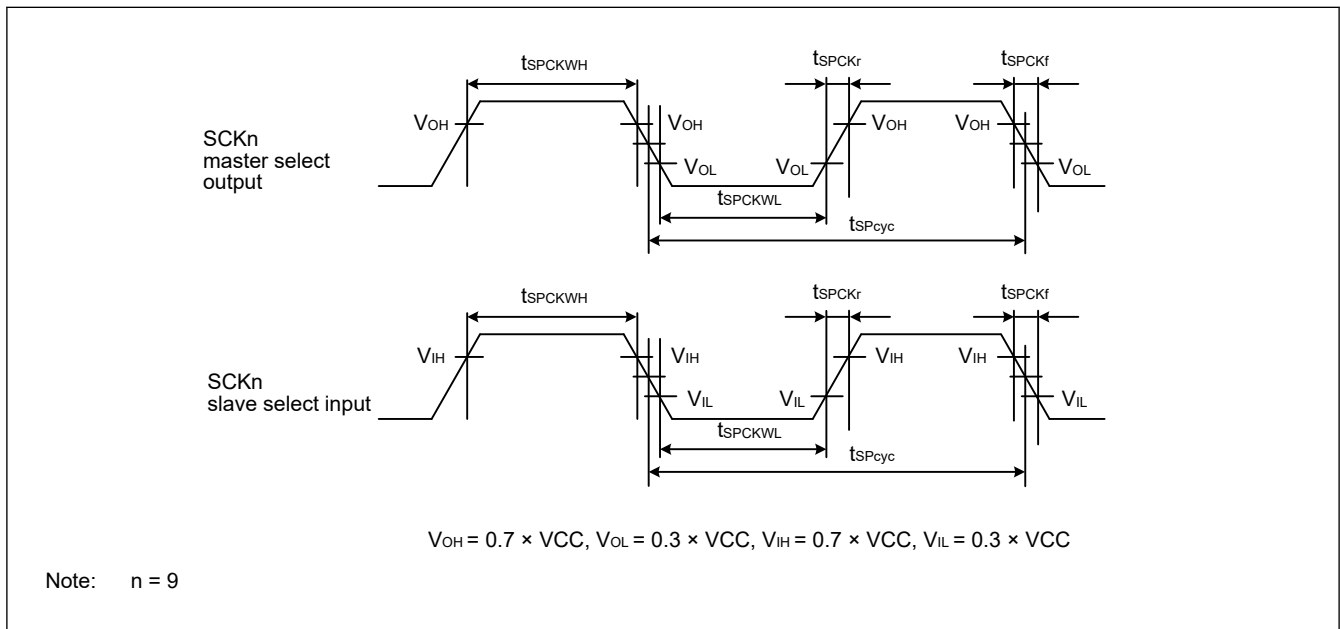

Figure 2.20 SCI simple SPI mode clock timing

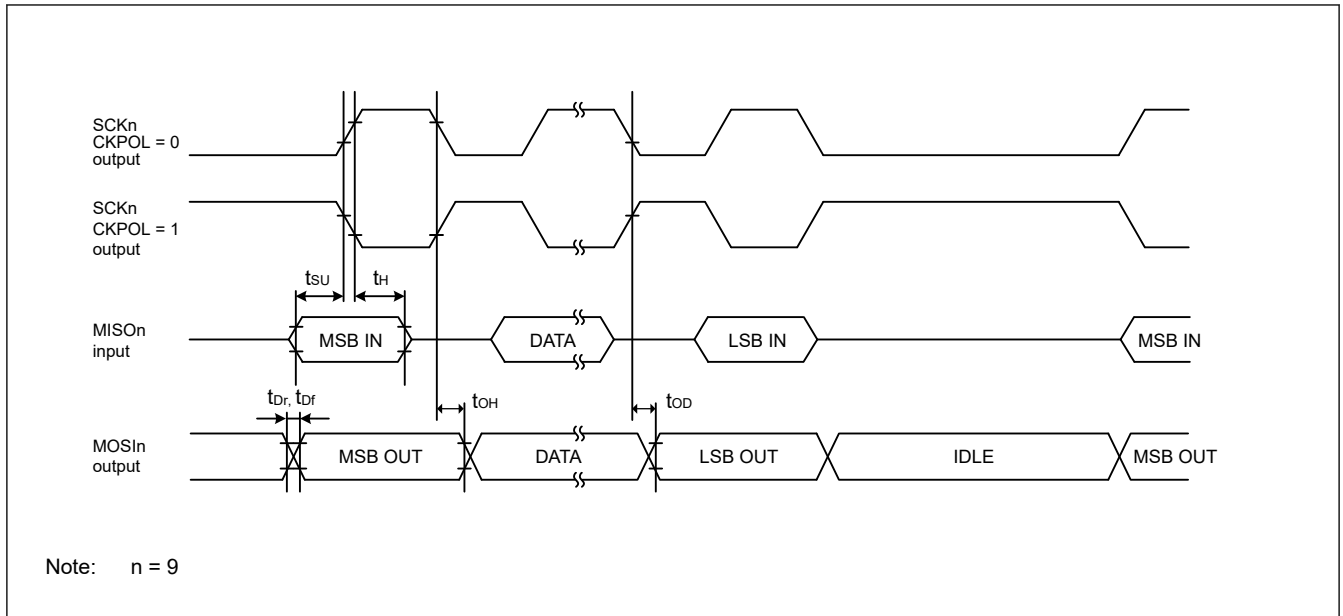

Figure 2.21 SCI simple SPI mode timing (master, CKPH = 1)

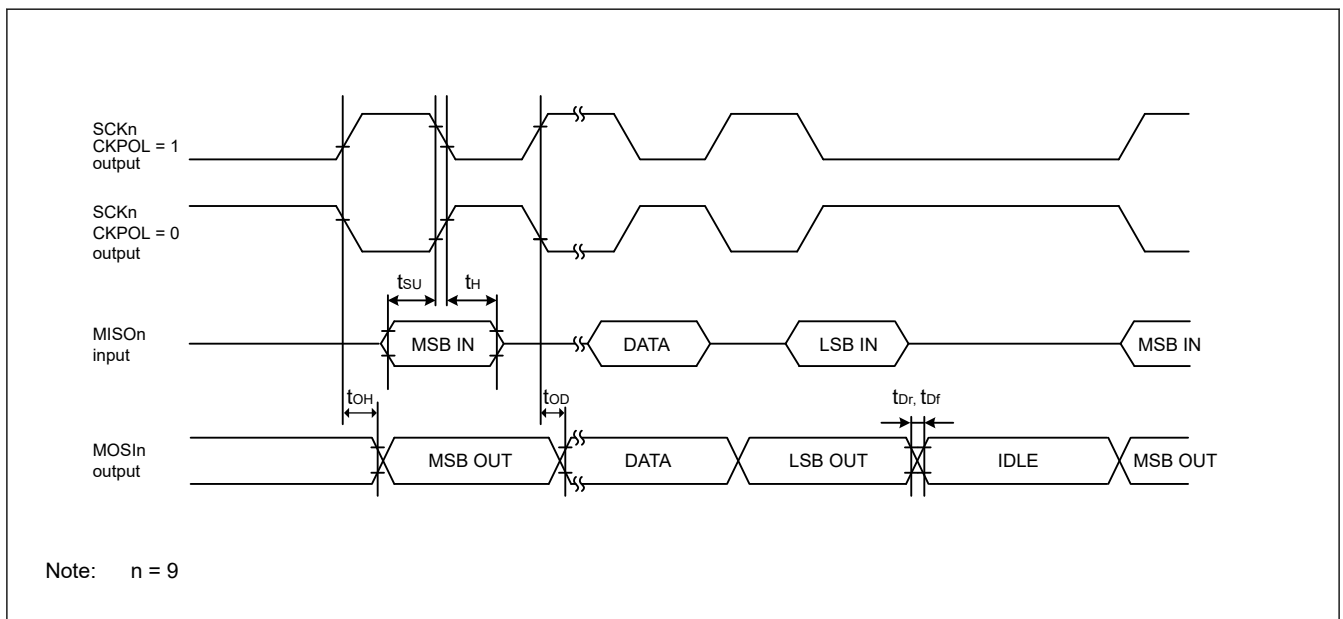

Figure 2.22 SCI simple SPI mode timing (master, CKPH = 0)

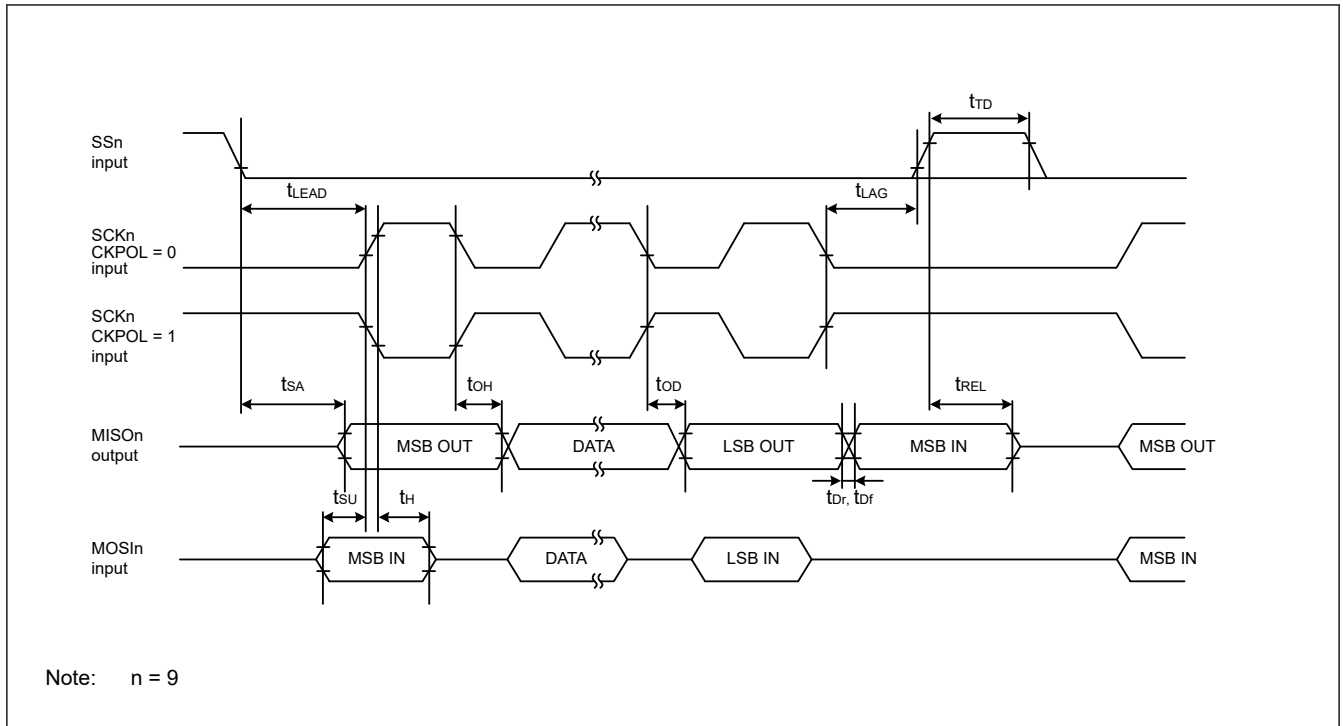

Figure 2.23 SCI simple SPI mode timing (slave, CKPH = 1)

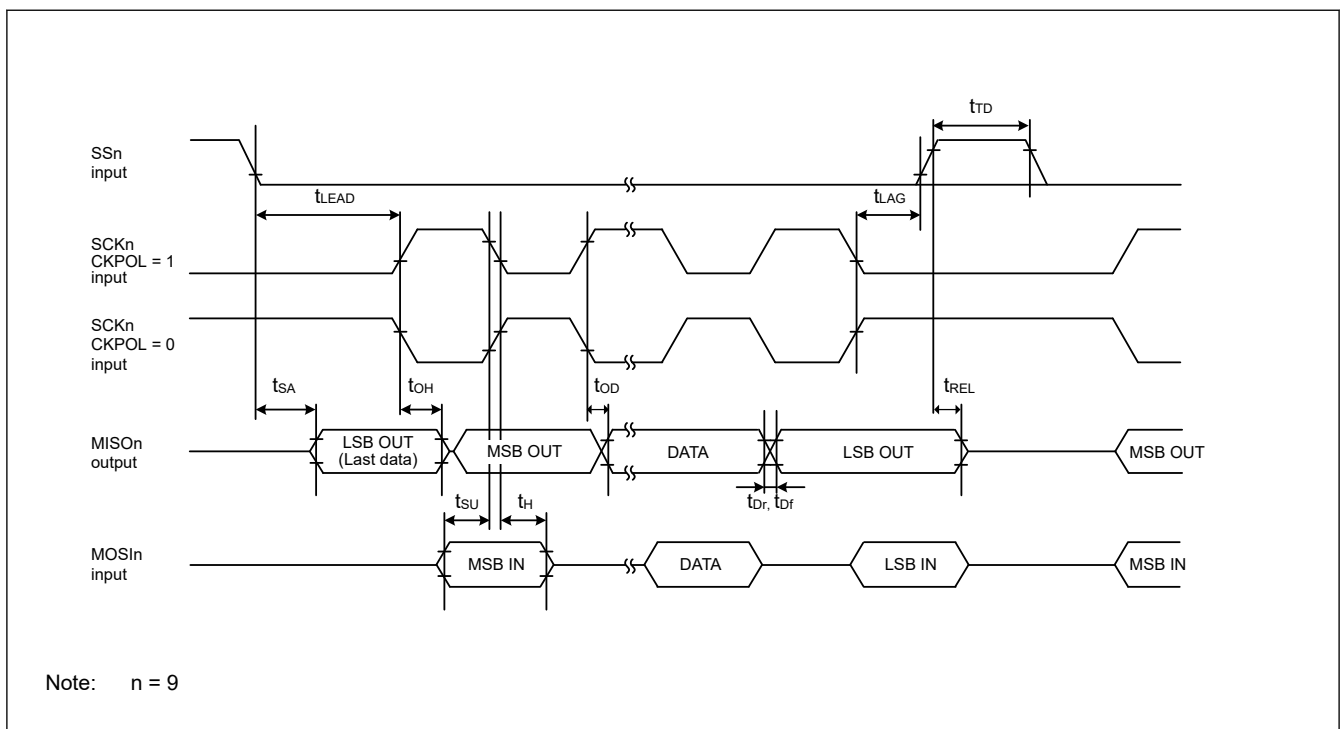

Figure 2.24 SCI simple SPI mode timing (slave, CKPH = 0)

Table 2.31 SCI timing (3)

Conditions: VCC = 2.7 to 5.5 V

Parameter	Symbol	Min	Max	Unit	Test conditions	
Simple IIC (Standard mode)	SDA input rise time	t_{Sr}	—	1000	ns	Figure 2.25
	SDA input fall time	t_{Sf}	—	300	ns	
	SDA input spike pulse removal time	t_{SP}	0	$4 \times t_{IICcyc}^{*1}$	ns	
	Data input setup time	t_{SDAS}	250	—	ns	
	Data input hold time	t_{SDAH}	0	—	ns	
	SCL, SDA capacitive load	C_b^{*2}	—	400	pF	
Simple IIC (Fast mode)	SDA input rise time	t_{Sr}	—	300	ns	Figure 2.25
	SDA input fall time	t_{Sf}	—	300	ns	
	SDA input spike pulse removal time	t_{SP}	0	$4 \times t_{IICcyc}^{*1}$	ns	
	Data input setup time	t_{SDAS}	100	—	ns	
	Data input hold time	t_{SDAH}	0	—	ns	
	SCL, SDA capacitive load	C_b^{*2}	—	400	pF	

Note 1. t_{IICcyc} : Clock cycle selected by the SMR.CKS[1:0] bits.

Note 2. C_b indicates the total capacity of the bus line.

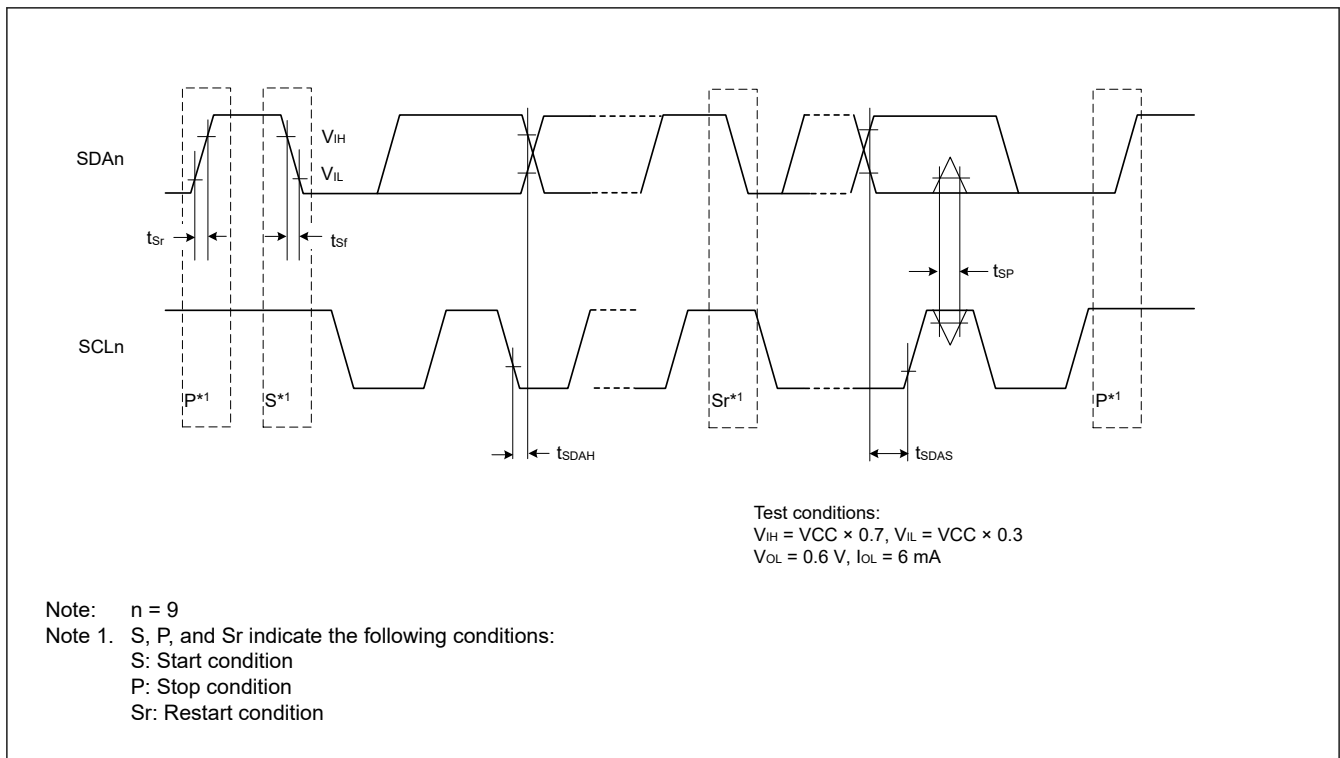

Figure 2.25 SCI simple IIC mode timing

2.3.9 SPI Timing

Table 2.32 SPI timing (1 of 3)

Parameter			Symbol	Min	Max	Unit ^{*1}	Test conditions	
SPI	RSPCK clock cycle	Master	$2.7\text{ V} \leq \text{VCC} \leq 5.5\text{ V}$	t_{SPcyc}	62.5	—	ns	Figure 2.26 C = 30 pF
			$2.4\text{ V} \leq \text{VCC} < 2.7\text{ V}$	125	—			
			$1.8\text{ V} \leq \text{VCC} < 2.4\text{ V}$	250	—			
			$1.6\text{ V} \leq \text{VCC} < 1.8\text{ V}$	500	—			
		Slave	$2.7\text{ V} \leq \text{VCC} \leq 5.5\text{ V}$	187.5	—			
			$2.4\text{ V} \leq \text{VCC} < 2.7\text{ V}$	375	—			
			$1.8\text{ V} \leq \text{VCC} < 2.4\text{ V}$	750	—			
			$1.6\text{ V} \leq \text{VCC} < 1.8\text{ V}$	1500	—			
	RSPCK clock high pulse width	Master		t_{SPCKWH}	$(t_{\text{SPcyc}} - t_{\text{SPCKr}} - t_{\text{SPCKf}}) / 2 - 3$	—	ns	
		Slave			$3 \times t_{\text{Pcyc}}$	—		
	RSPCK clock low pulse width	Master		t_{SPCKWL}	$(t_{\text{SPcyc}} - t_{\text{SPCKr}} - t_{\text{SPCKf}}) / 2 - 3$	—	ns	
		Slave			$3 \times t_{\text{Pcyc}}$	—		
RSPCK clock rise and fall time	Output	$2.7\text{ V} \leq \text{VCC} \leq 5.5\text{ V}$	t_{SPCKr}	—	10	ns		
		$2.4\text{ V} \leq \text{VCC} < 2.7\text{ V}$	t_{SPCKf}	—	15			
		$1.8\text{ V} \leq \text{VCC} \leq 2.4\text{ V}$	—	20				
		$1.6\text{ V} \leq \text{VCC} < 1.8\text{ V}$	—	30				
	Input			—	0.1	$\mu\text{s/V}$		

Table 2.32 SPI timing (2 of 3)

Parameter				Symbol	Min	Max	Unit*1	Test conditions	
SPI	Data input setup time	Master	2.7 V ≤ VCC ≤ 5.5 V		t _{SU}	10	—	ns	Figure 2.27 to Figure 2.32 C = 30 pF
			2.4 V ≤ VCC < 2.7 V	16 MHz < PCLKB ≤ 32 MHz		30	—		
				PCLKB ≤ 16 MHz		10	—		
			1.8 V ≤ VCC < 2.4 V	16 MHz < PCLKB ≤ 32 MHz		55	—		
				8 MHz < PCLKB ≤ 16 MHz		30	—		
				PCLKB ≤ 8 MHz		10	—		
		1.6 V ≤ VCC < 1.8 V		10		—			
		Slave	2.4 V ≤ VCC ≤ 5.5 V			10	—		
			1.8 V ≤ VCC < 2.4 V			15	—		
	1.6 V ≤ VCC < 1.8 V		20	—					
	Data input hold time	Master (RSPCK is PCLKB/2)		t _{HF}	0	—	ns		
		Master (RSPCK is not PCLKB/2)		t _H	t _{Pcyc}	—			
		Slave		t _H	20	—			
SPI	SSL setup time	Master	1.8 V ≤ VCC ≤ 5.5 V		t _{LEAD}	-30 + N × t _{SPcyc} ^{*2}	—	ns	
			1.6 V ≤ VCC < 1.8 V			-50 + N × t _{SPcyc} ^{*2}	—		
		Slave		6 × t _{Pcyc}		—	ns		
	SSL hold time	Master		t _{LAG}	-30 + N × t _{SPcyc} ^{*3}	—	ns		
		Slave		6 × t _{Pcyc}	—	ns			
	Data output delay time	Master	2.7 V ≤ VCC ≤ 5.5 V		t _{OD}	—	14	ns	
2.4 V ≤ VCC < 2.7 V			—	20					
1.8 V ≤ VCC < 2.4 V			—	25					
1.6 V ≤ VCC < 1.8 V			—	30					
Slave		2.7 V ≤ VCC ≤ 5.5 V		—		50			
		2.4 V ≤ VCC < 2.7 V		—		60			
		1.8 V ≤ VCC < 2.4 V		—		85			
		1.6 V ≤ VCC < 1.8 V		—		110			
Data output hold time	Master		t _{OH}	0	—	ns			
	Slave			0	—				
Successive transmission delay time	Master		t _{TD}	t _{SPcyc} + 2 × t _{Pcyc}	8 × t _{SPcyc} + 2 × t _{Pcyc}	ns			
	Slave			6 × t _{Pcyc}	—				

Table 2.32 SPI timing (3 of 3)

Parameter		Symbol	Min	Max	Unit*1	Test conditions			
SPI	MOSI and MISO rise and fall time	Output	$2.7\text{ V} \leq \text{VCC} \leq 5.5\text{ V}$	t_{Dr}, t_{Df}	—	10	ns Figure 2.27 to Figure 2.32 C = 30 pF		
			$2.4\text{ V} \leq \text{VCC} < 2.7\text{ V}$	—	15				
			$1.8\text{ V} \leq \text{VCC} < 2.4\text{ V}$	—	20				
			$1.6\text{ V} \leq \text{VCC} < 1.8\text{ V}$	—	30				
		Input		—	1	μs			
		SSL rise and fall time	Output	$2.7\text{ V} \leq \text{VCC} \leq 5.5\text{ V}$	t_{SSLr}, t_{SSLf}	—		10	ns
				$2.4\text{ V} \leq \text{VCC} < 2.7\text{ V}$	—	15			
				$1.8\text{ V} \leq \text{VCC} < 2.4\text{ V}$	—	20			
	$1.6\text{ V} \leq \text{VCC} < 1.8\text{ V}$			—	30				
	Input		—	1	μs				
	Slave access time		$2.4\text{ V} \leq \text{VCC} \leq 5.5\text{ V}$	t_{SA}	—	$2 \times t_{Pcyc} + 100$	ns Figure 2.31 and Figure 2.32 C = 30 pF		
			$1.8\text{ V} \leq \text{VCC} < 2.4\text{ V}$		—	$2 \times t_{Pcyc} + 140$			
$1.6\text{ V} \leq \text{VCC} < 1.8\text{ V}$			—		$2 \times t_{Pcyc} + 180$				
Slave output release time		$2.4\text{ V} \leq \text{VCC} \leq 5.5\text{ V}$	t_{REL}	—	$2 \times t_{Pcyc} + 100$	ns			
		$1.8\text{ V} \leq \text{VCC} < 2.4\text{ V}$		—	$2 \times t_{Pcyc} + 140$				
		$1.6\text{ V} \leq \text{VCC} < 1.8\text{ V}$		—	$2 \times t_{Pcyc} + 180$				

Note 1. t_{Pcyc} : PCLKB cycle.

Note 2. N is set as an integer from 1 to 8 by the SPCKD register.

Note 3. N is set as an integer from 1 to 8 by the SSLND register.



Figure 2.26 SPI clock timing



Figure 2.27 SPI timing (master, CPHA = 0) (bit rate: PCLKB division ratio is set to any value other than 1/2)

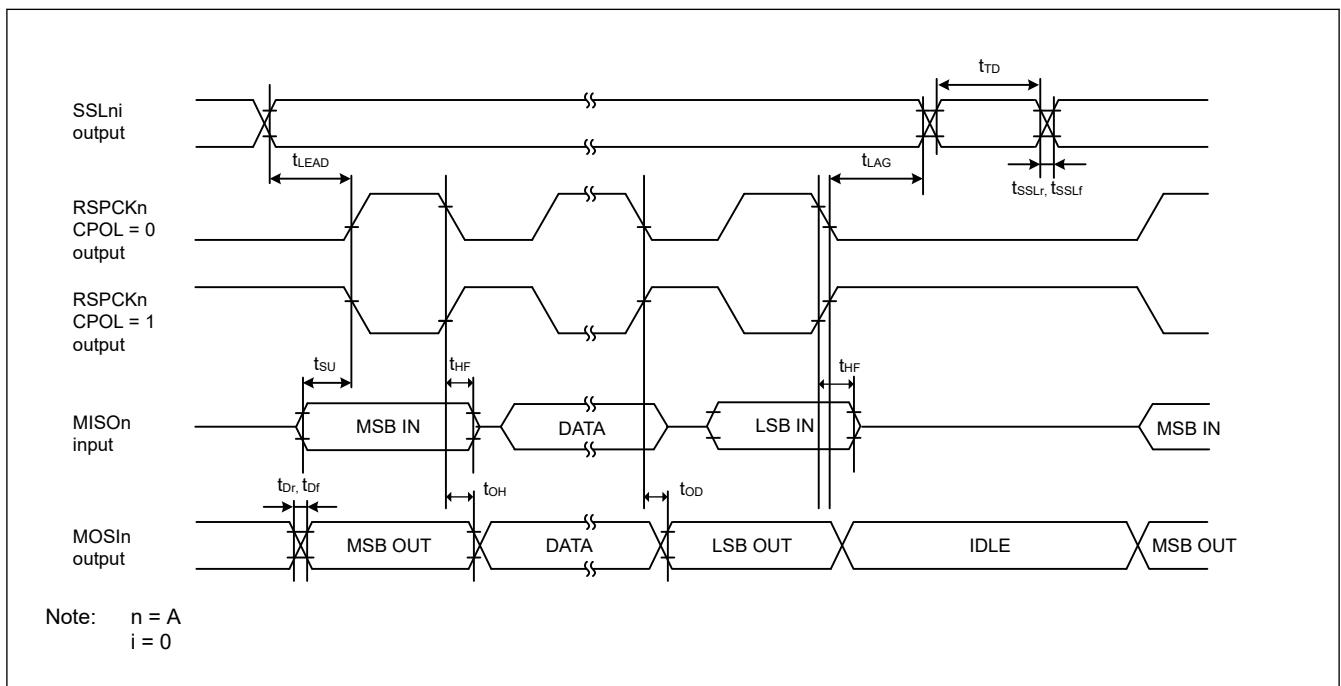

Figure 2.28 SPI timing (master, CPHA = 0) (bit rate: PCLKB division ratio is set to 1/2)



Figure 2.29 SPI timing (master, CPHA = 1) (bit rate: PCLKB division ratio is set to any value other than 1/2)



Figure 2.30 SPI timing (master, CPHA = 1) (bit rate: PCLKB division ratio is set to 1/2)

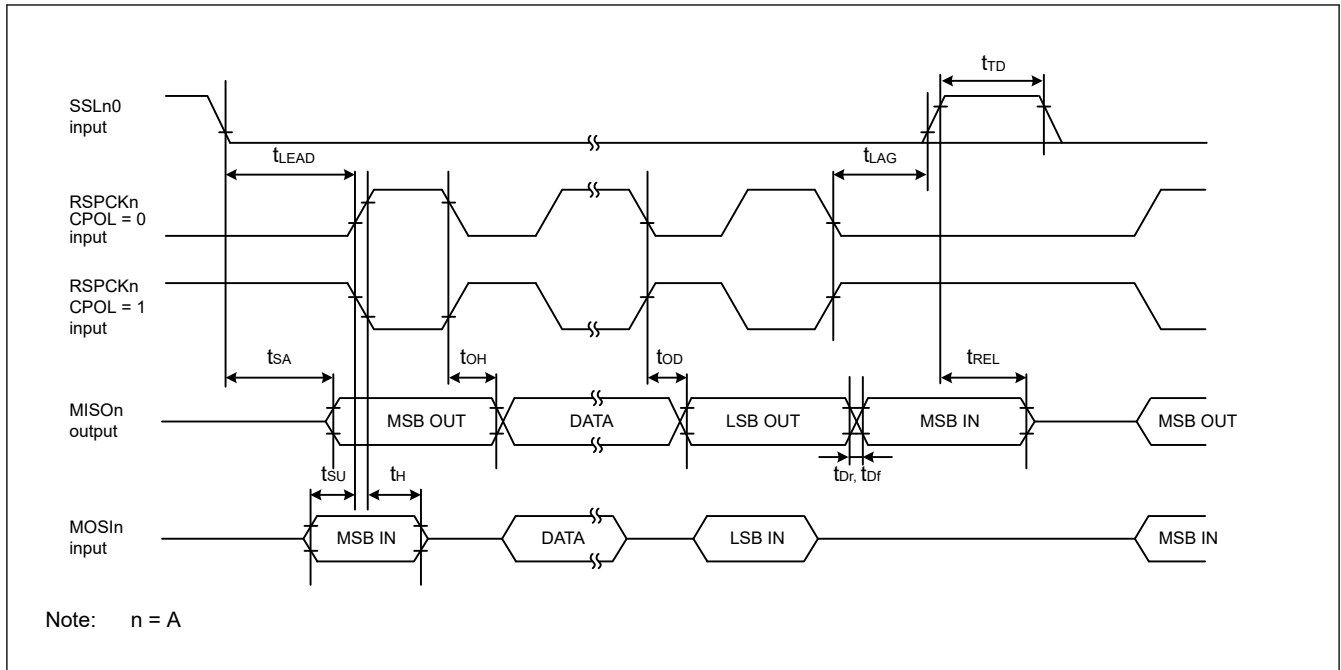

Figure 2.31 SPI timing (slave, CPHA = 0)

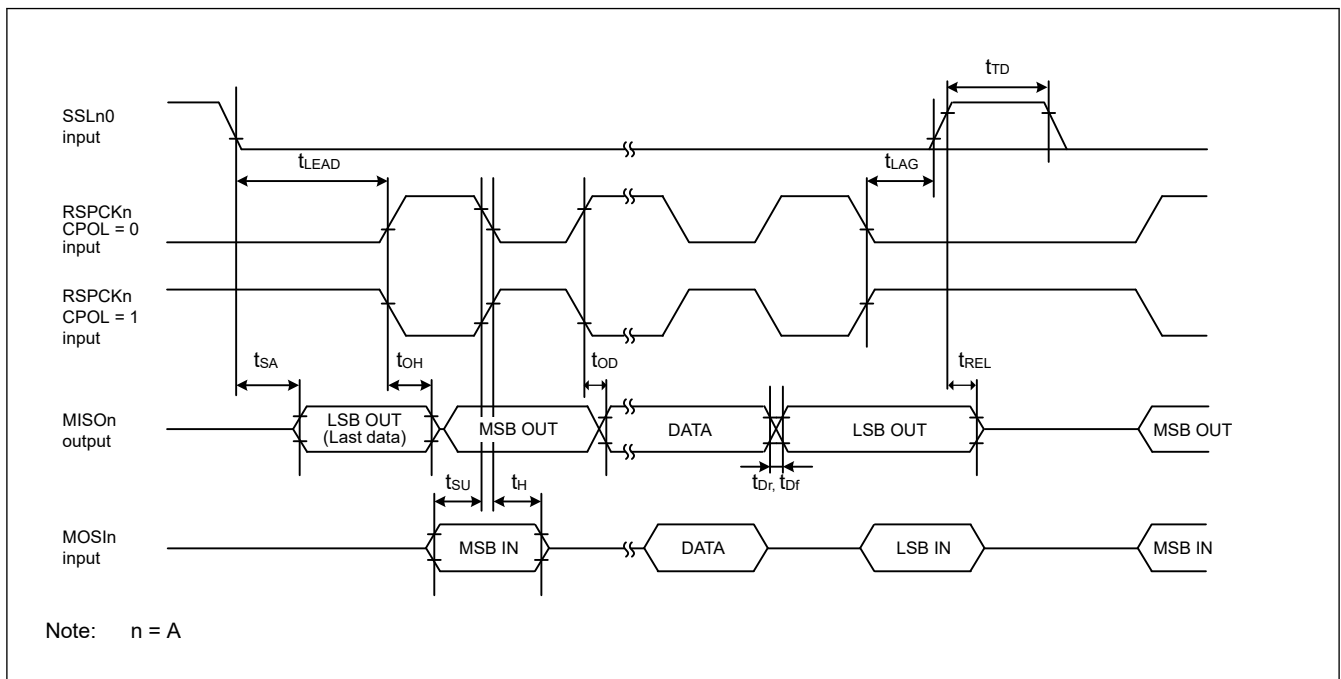

Figure 2.32 SPI timing (slave, CPHA = 1)

2.3.10 I3C Timing

Table 2.33 IIC timing

Conditions: VCC = 2.7 to 5.5 V

Parameter		Symbol	Min*1	Max	Unit	Test conditions
IIC (standard mode, SMBus)	SCL cycle time	t _{SCL}	6 (40) × t _{IICcyc} + 4 × t _{Pcyc} + 1300	—	ns	Figure 2.33
	SCL high pulse width	t _{SCLH}	3 (20) × t _{IICcyc} + 2 × t _{Pcyc} + 300	—	ns	
	SCL low pulse width	t _{SCLL}	3 (20) × t _{IICcyc} + 2 × t _{Pcyc} + 800	—	ns	
	SCL, SDA rise time	t _{Sr}	—	1000	ns	
	SCL, SDA fall time	t _{Sf}	—	300	ns	
	SCL, SDA spike pulse removal time	t _{SP}	0	1 (16) × t _{IICcyc}	ns	
	SDA bus free time	t _{BUF}	3 (20) × t _{IICcyc} + 300	—	ns	
	Hold time for START condition	t _{STAH}	t _{IICcyc} + 300	—	ns	
	Setup time for repeated START condition	t _{STAS}	1000	—	ns	
	Setup time for STOP condition	t _{STOS}	1000	—	ns	
	Data setup time	t _{SDAS}	t _{IICcyc} + 50	—	ns	
	Data hold time	t _{SDAH}	0	—	ns	
	SCL, SDA capacitive load	C _b	—	400	pF	
IIC (Fast mode)	SCL cycle time	t _{SCL}	6 (40) × t _{IICcyc} + 4 × t _{Pcyc} + 600	—	ns	Figure 2.33
	SCL high pulse width	t _{SCLH}	3 (20) × t _{IICcyc} + 2 × t _{Pcyc} + 300	—	ns	
	SCL low pulse width	t _{SCLL}	3 (20) × t _{IICcyc} + 2 × t _{Pcyc} + 300	—	ns	
	SCL, SDA rise time	t _{Sr}	—	300	ns	
	SCL, SDA fall time	t _{Sf}	—	300	ns	
	SCL, SDA spike pulse removal time	t _{SP}	0	1 (16) × t _{IICcyc}	ns	
	SDA bus free time	t _{BUF}	3 (20) × t _{IICcyc} + 300	—	ns	
	Hold time for START condition	t _{STAH}	t _{IICcyc} + 300	—	ns	
	Setup time for repeated START condition	t _{STAS}	300	—	ns	
	Setup time for STOP condition	t _{STOS}	300	—	ns	
	Data setup time	t _{SDAS}	t _{IICcyc} + 50	—	ns	
	Data hold time	t _{SDAH}	0	—	ns	
	SCL, SDA capacitive load	C _b	—	400	pF	

Note: t_{IICcyc}: IIC internal reference clock (IICφ) cycle, t_{Pcyc}: PCLKD cycle

Note 1. Values in parentheses apply when INCTL.DNFS[3:0] is set to 1111b while the digital filter is enabled with DNFE.DNFE set to 1.

Table 2.34 IIC timing (Fast-mode+)

Conditions: VCC = 2.7 to 5.5 V

Parameter	Symbol	Min*1	Max	Unit	Test conditions	
IIC (Fast-mode+)	SCL cycle time	t_{SCL}	$6 (40) \times t_{IICcyc} + 4 \times t_{Pcyc} + 240$	—	ns	Figure 2.33
	SCL high pulse width	t_{SCLH}	$3 (20) \times t_{IICcyc} + 2 \times t_{Pcyc} + 120$	—	ns	
	SCL low pulse width	t_{SCLL}	$3 (20) \times t_{IICcyc} + 2 \times t_{Pcyc} + 120$	—	ns	
	SCL, SDA rise time	t_{Sr}	—	120	ns	
	SCL, SDA fall time	t_{Sf}	—	120	ns	
	SCL, SDA spike pulse removal time	t_{SP}	—	$1 (16) \times t_{IICcyc}$	ns	
	SDA bus free time	t_{BUF}	$3 (20) \times t_{IICcyc} + 120$	—	ns	
	Hold time for START condition	t_{STAH}	$t_{IICcyc} + 135$	—	ns	
	Setup time for repeated START condition	t_{STAS}	260	—	ns	
	Setup time for STOP condition	t_{STOS}	260	—	ns	
	Data setup time	t_{SDAS}	50	—	ns	
	Data hold time	t_{SDAH}	0	—	ns	
	SCL, SDA capacitive load	C_b	—	550	pF	

Note: t_{IICcyc} : IIC internal reference clock (IIC ϕ) cycle, t_{Pcyc} : PCLKD cycle.

Note 1. Values in parentheses apply when INCTL.DNFS[3:0] is set to 1111b while the digital filter is enabled with INCTL.DNFE set to 1.

Table 2.35 IIC timing (HS mode)

Conditions: VCC = 2.7 to 5.5 V

Parameter		Symbol	Cb = 100 pF		Cb = 400 pF		Unit	Test conditions
			Min*1	Max	Min*1	Max		
IIC(HS mode)	SCL cycle time	t _{SCL}	330 (+ 10 × t _{IICcyc}) when PCLKD = 64 MHz 390 (+ 10 × t _{IICcyc}) when PCLKD = 48 MHz	—	500 (+ 10 × t _{IICcyc}) when PCLKD = 64 MHz *2 560 (+ 10 × t _{IICcyc}) when PCLKD = 48 MHz	—	ns	Figure 2.33
	SCL high pulse width	t _{SCLH}	125 (+ 5 × t _{IICcyc}) when PCLKD = 64 MHz 155 (+ 5 × t _{IICcyc}) when PCLKD = 48 MHz	—	140 (+ 5 × t _{IICcyc}) when PCLKD = 64 MHz 170 (+ 5 × t _{IICcyc}) when PCLKD = 48 MHz	—	ns	
	SCL low pulse width	t _{SCLL}	205 (+ 5 × t _{IICcyc}) when PCLKD = 64 MHz 230 (+ 5 × t _{IICcyc}) when PCLKD = 48 MHz	—	320 (+ 5 × t _{IICcyc}) when PCLKD = 64 MHz 350 (+ 5 × t _{IICcyc}) when PCLKD = 48 MHz	—	ns	
	SCL rise time	t _{Sr}	—	40	—	80	ns	
	SCL rise time after a repeated START condition and after an acknowledge bit	t _{Sr}	—	80	—	160	ns	
	SCL fall time	t _{Sf}	—	40	—	80	ns	
	SDA fall time	t _{Sf}	—	80	—	160	ns	
	SDA fall time	t _{Sf}	—	80	—	160	ns	
	SCL, SDA spike pulse removal time	t _{SP}	0	1 (4) × t _{IICcyc}	0	1 (4) × t _{IICcyc}	ns	
	Hold time for START condition	t _{STA H}	t _{IICcyc} + 135	—	t _{IICcyc} + 135	—	ns	
	Setup time for repeated START condition	t _{STA S}	160	—	160	—	ns	
	Setup time for STOP condition	t _{STO S}	160	—	160	—	ns	
	Data setup time	t _{SDA S}	10	—	10	—	ns	
	Data hold time	t _{SDA H}	0	80	0	150	ns	
SCL, SDA capacitive load	C _b	—	100	—	400	pF		

Note: t_{IICcyc}: IIC internal reference clock (IICφ) cycle, t_{Pcyc}: PCLKD cycle.

Note 1. Values in parentheses apply when INCTL.DNFS[3:0] is set to 1111b while the digital filter is enabled with INCTL.DNFE set to 1.

Note 2. The maximum SCL clock frequency is 1.7MHz.

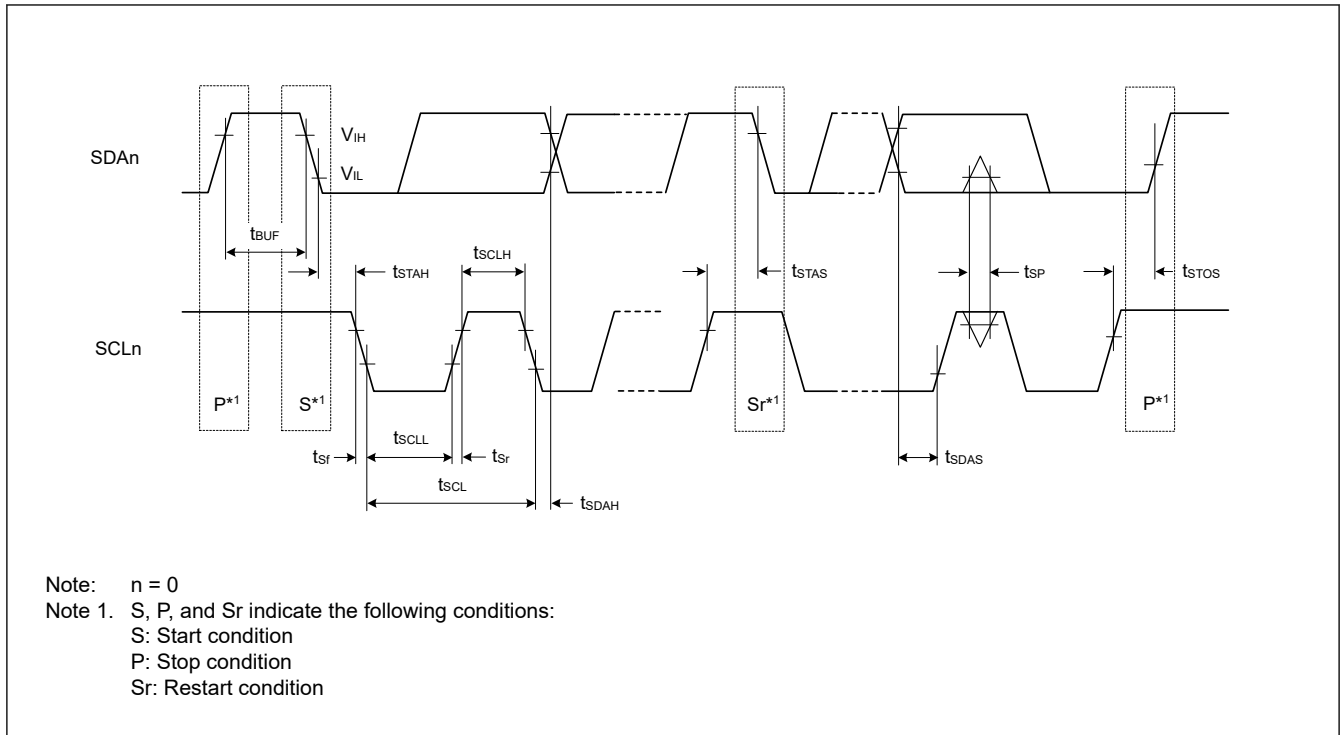

Figure 2.33 I²C bus interface input/output timing

Table 2.36 I³C timing (Open Drain Timing Parameters)

Conditions: VCC = 2.97 to 3.63 V

Parameter	Symbol	Timing Diagram	Min	Max	Units	Notes
SCL Clock Low Period	t _{LOW_OD}	Figure 2.36	200	—	ns	1, 2
	t _{DIG_OD_L}	Figure 2.36	t _{LOW_ODmin} + t _{fDA_ODmin}	—	ns	—
SDA Signal Fall Time	t _{fDA_OD}	Figure 2.36	t _{CF}	33	ns	—
SDA Data Setup Time Open Drain Mode	t _{SU_OD}	Figure 2.35	4	—	ns	1
		Figure 2.36				
Clock After START (S) Condition	t _{CAS}	Figure 2.36	38.4	For ENTAS0: 1 μ	seconds	5, 6
				For ENTAS1: 100 μ		
				For ENTAS2: 2 m		
				For ENTAS3: 50 m		
Clock Before STOP (P) Condition	t _{CBP}	Figure 2.37	t _{CASmin}	—	seconds	—
Current Master to Secondary Master Overlap time during handoff	t _{MMOVerlap}	Figure 2.42	t _{DIG_OD_Lmin}	—	ns	—
Bus Available Condition	t _{AVAL}	—	1	—	μs	7
Bus Idle Condition	t _{IDLE}	—	1	—	ms	—
Time Interval Where New Master Not Driving SDA Low	t _{MMLock}	Figure 2.42	t _{AVALmin}	—	μs	—

- Note:
1. This is approximately equal to t_{LOWmin} + t_{DS_ODmin} + t_{rDA_ODtyp} + t_{SU_ODmin}.
 2. The Master may use a shorter Low period if it knows that this is safe, i.e., that SDA is already above V_{IH}.
 3. On a Legacy Bus where I²C Devices need to see Start.
 4. Slaves that do not support the optional ENTASx CCCs shall use the t_{CAS} Max value shown for ENTAS3
 5. On a Mixed Bus with Fm Legacy I²C Devices, t_{AVAL} is 300 ns shorter than the Fm Bus Free Condition time (t_{BUF})

Table 2.37 I3C timing (Push-Pull Timing Parameters for SDR)

Parameter	Symbol	Timing Diagram	Min	Max	Units	Notes
SCL Clock Frequency	f_{SCL}	—	0.01	4.6 (when PCLKD = 64 M) 3.4 (when PCLKD = 48 M)	M Hz	1
SCL Clock Low Period	t_{LOW}	Figure 2.34	80 (when PCLKD = 64 M) 104 (when PCLKD = 48 M)	—	ns	—
	t_{DIG_L}	Figure 2.34	88 (when PCLKD = 64 M) 112 (when PCLKD = 48 M)	—	ns	2,4
SCL Clock High Period	t_{HIGH}	Figure 2.34	112 (when PCLKD = 64 M) 148 (when PCLKD = 48 M)	—	ns	—
	t_{DIG_H}	Figure 2.34	120 (when PCLKD = 64 M) 156 (when PCLKD = 48 M)	—	ns	2
Clock in to Data Out for Slave	t_{SCO}	Figure 2.39	—	42	ns	—
SCL Clock Rise Time	t_{CR}	Figure 2.34	—	$150 * 1 / f_{SCL}$ (capped at 60)	ns	—
SCL Clock Fall Time	t_{CF}	Figure 2.34	—	$150 * 1 / f_{SCL}$ (capped at 60)	ns	—
SDA Signal Data Hold in Push-Pull Mode	Master t_{HD_PP}	Figure 2.38	$t_{CR} + 3$ and $t_{CF} + 3$	—	—	4
	Slave t_{HD_PP}	Figure 2.40	0	—	—	—
SDA Signal Data Setup in Push-Pull Mode	t_{SU_PP}	Figure 2.38	4	N/A	ns	—
		Figure 2.39				
Clock After Repeated START (Sr)	t_{CASr}	Figure 2.41	t_{CASmin}	N/A	ns	—
Clock Before Repeated START (Sr)	t_{CBSr}	Figure 2.41	t_{CASmin}	N/A	ns	—
Capacitive Load per Bus Line (SDA/SCL)	C_b	—	—	50	pF	—

- Note:
- $f_{SCL} = 1 / (t_{DIG_L} + t_{DIG_H})$
 - t_{DIG_L} and t_{DIG_H} are the clock Low and High periods as seen at the receiver end of the I3C Bus using VIL and VIH (see Figure 2.34)
 - As both edges are used, the hold time must be satisfied for the respective edges, for example, $t_{CF} + 3$ for falling edge clocks, and $t_{CR} + 3$ for rising edge clocks.

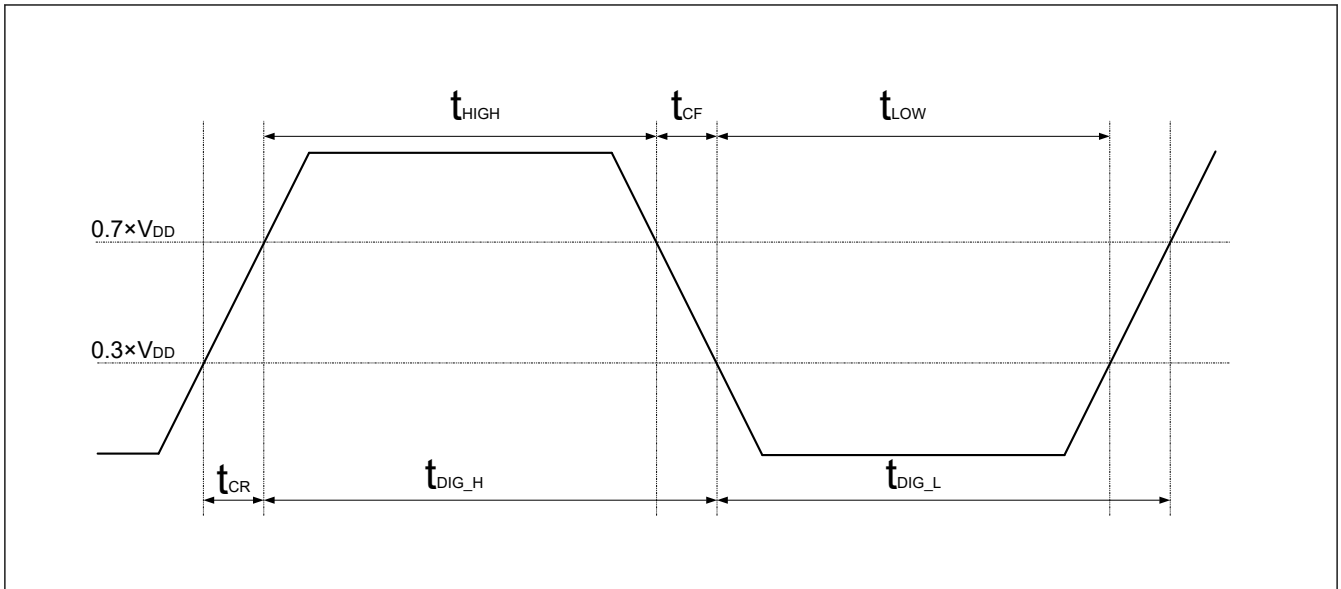

Figure 2.34 t_{DIG_H} and t_{DIG_L}

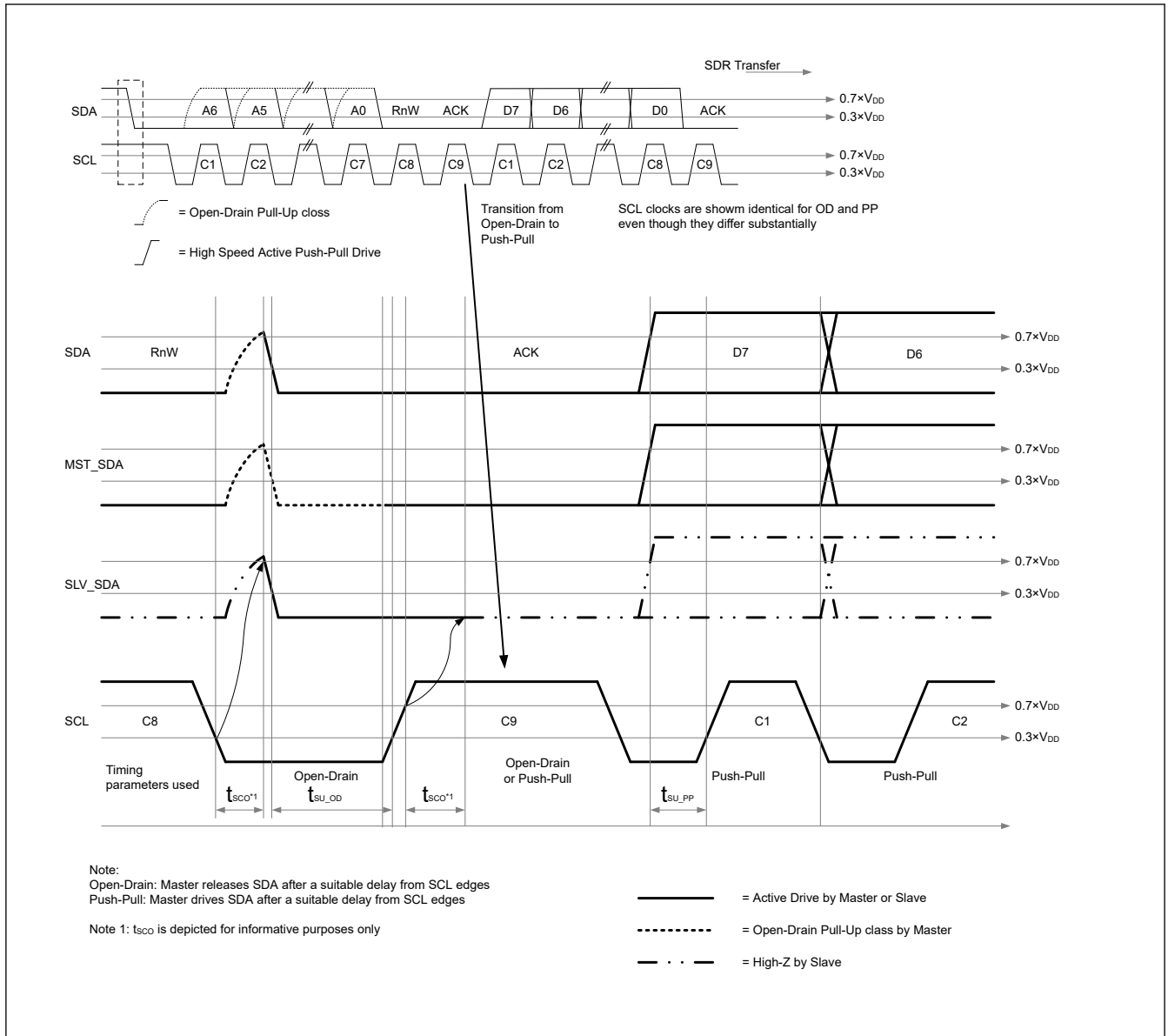

Figure 2.35 I3C Data Transfer – ACK by Slave

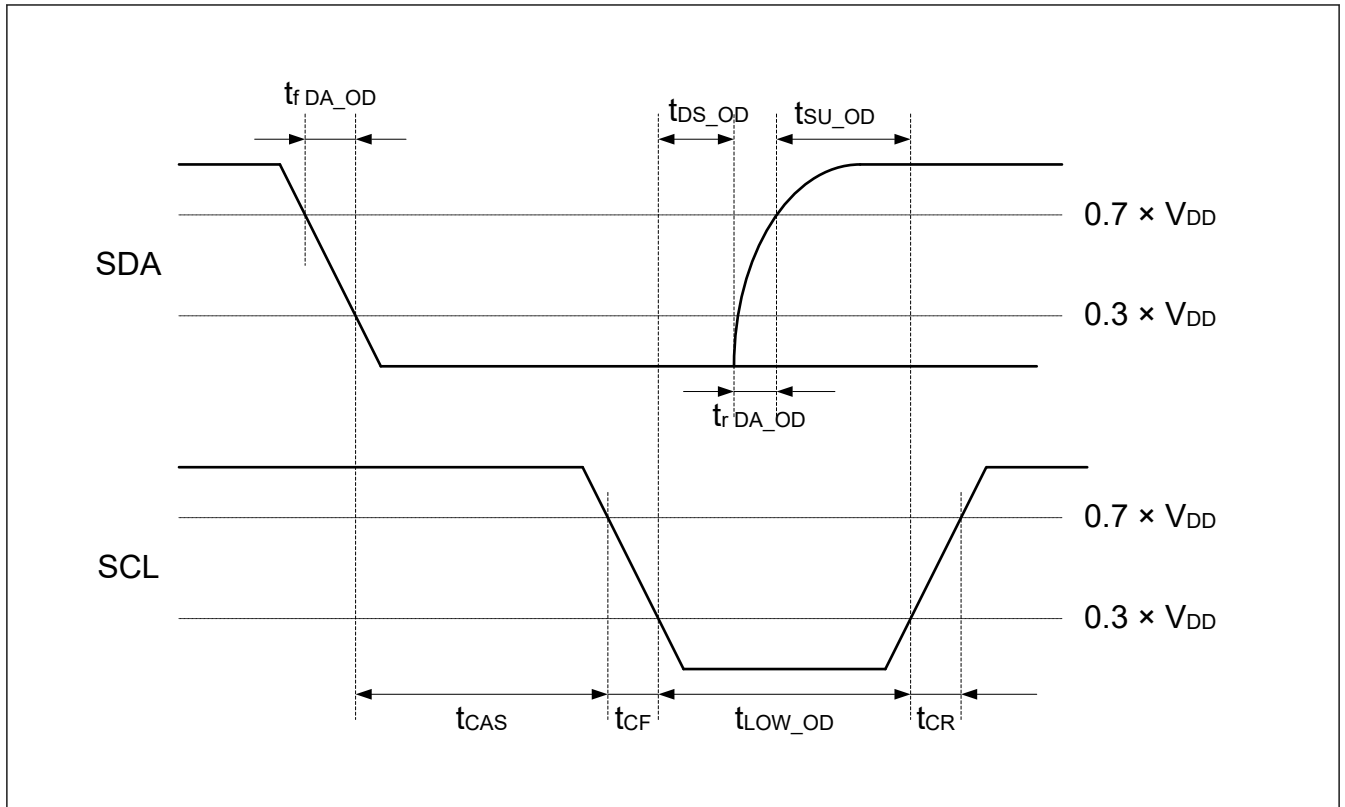

Figure 2.36 I3C START condition Timing

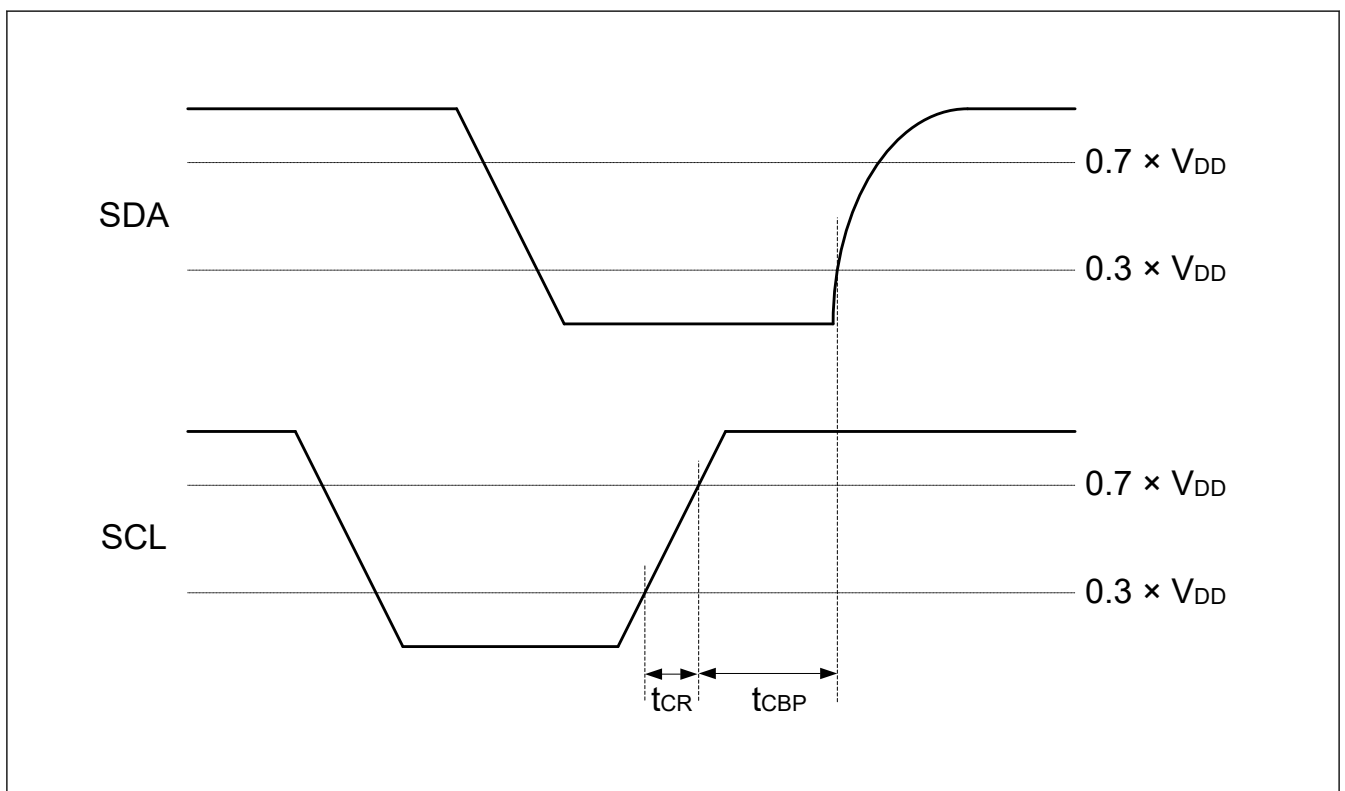

Figure 2.37 I3C STOP condition Timing

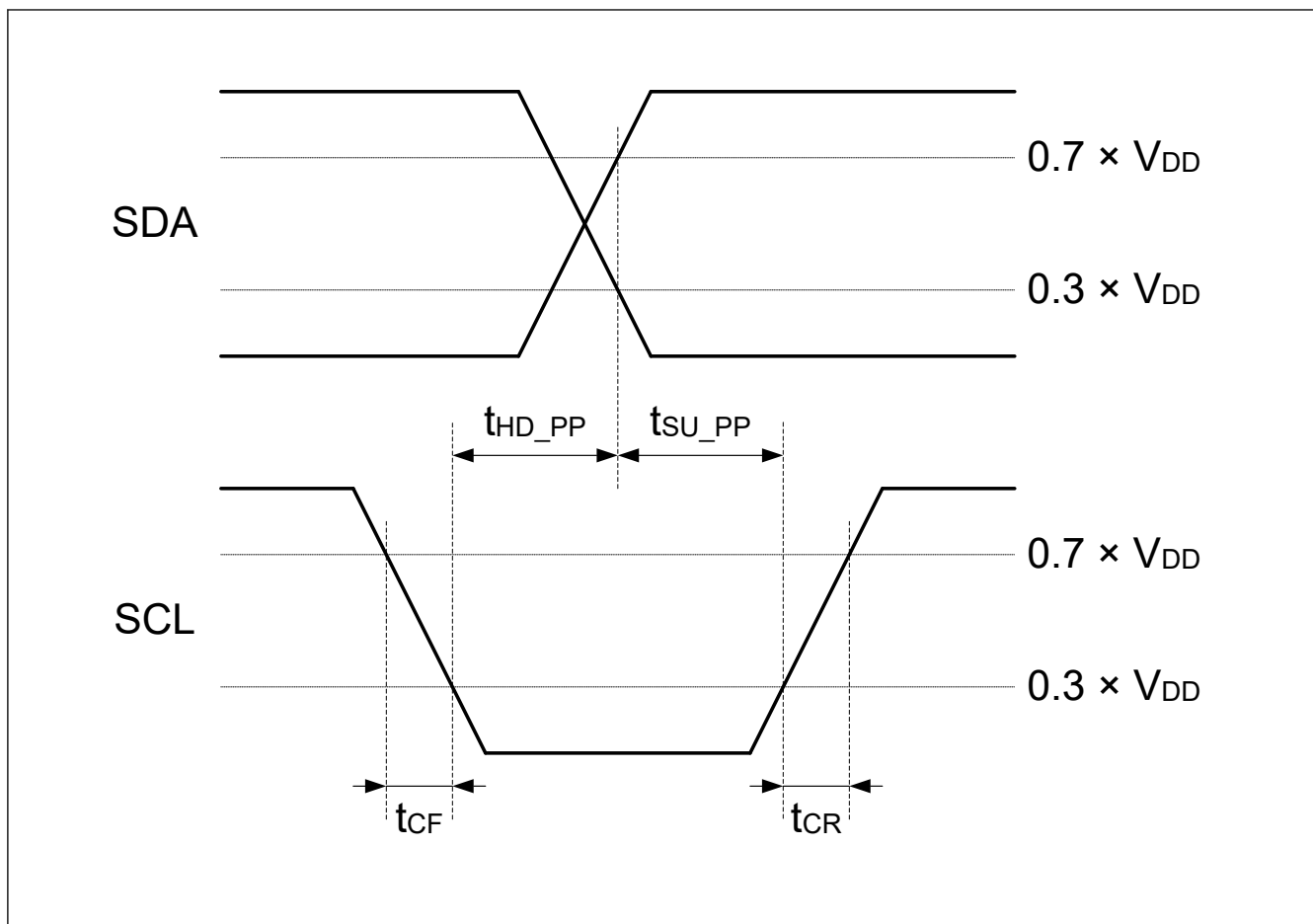

Figure 2.38 I3C Master Out Timing

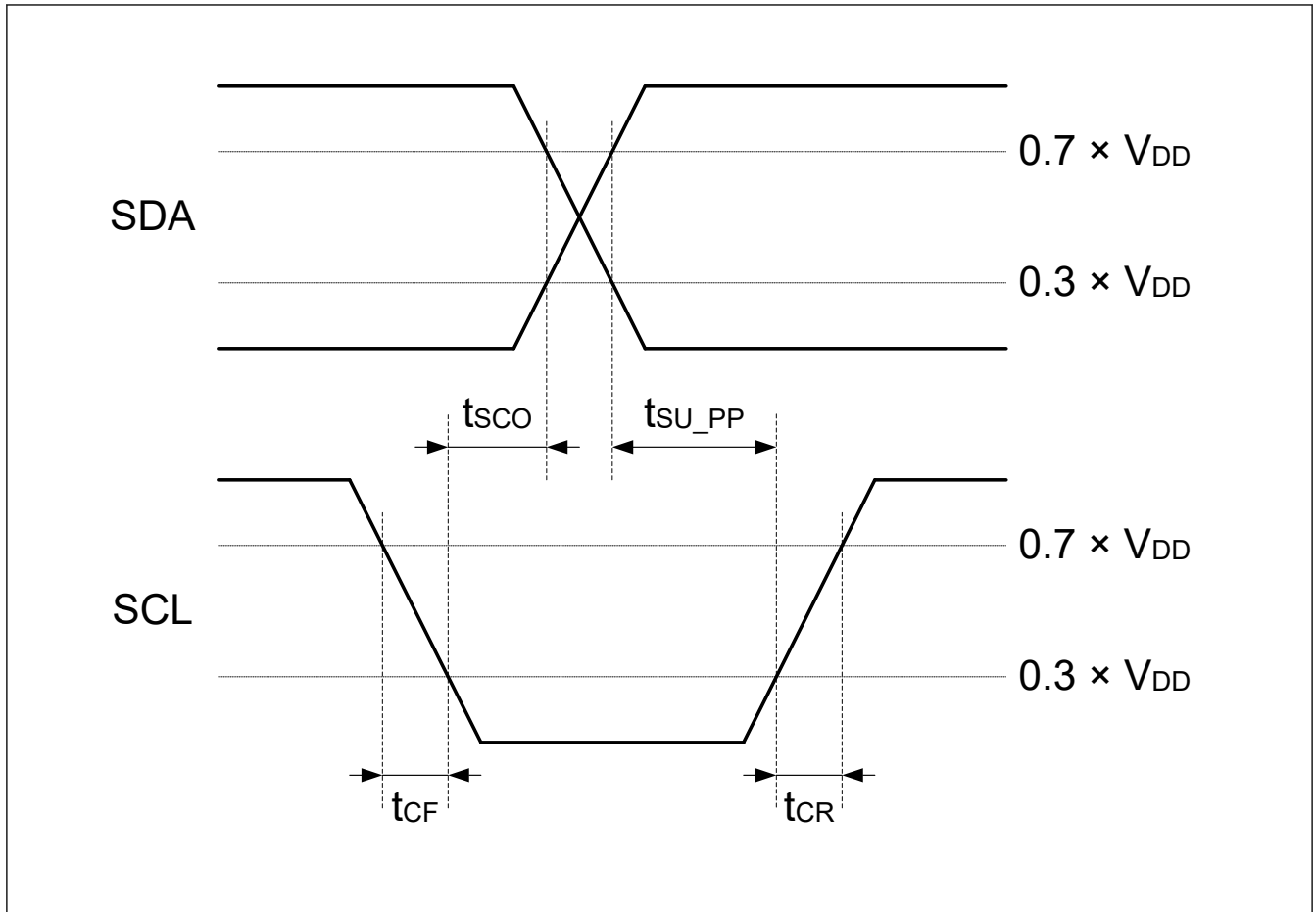

Figure 2.39 I3C Slave Out Timing

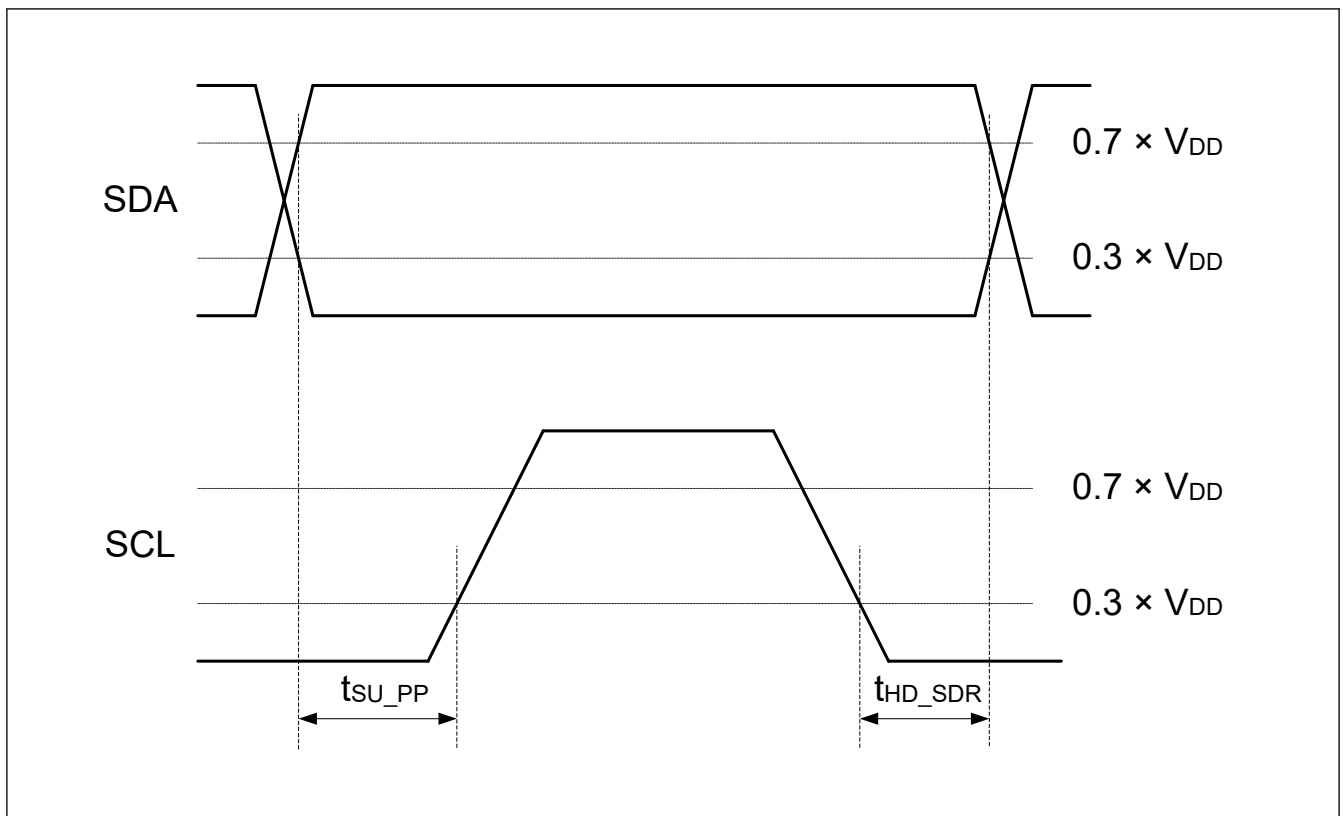

Figure 2.40 Master SDR Timing

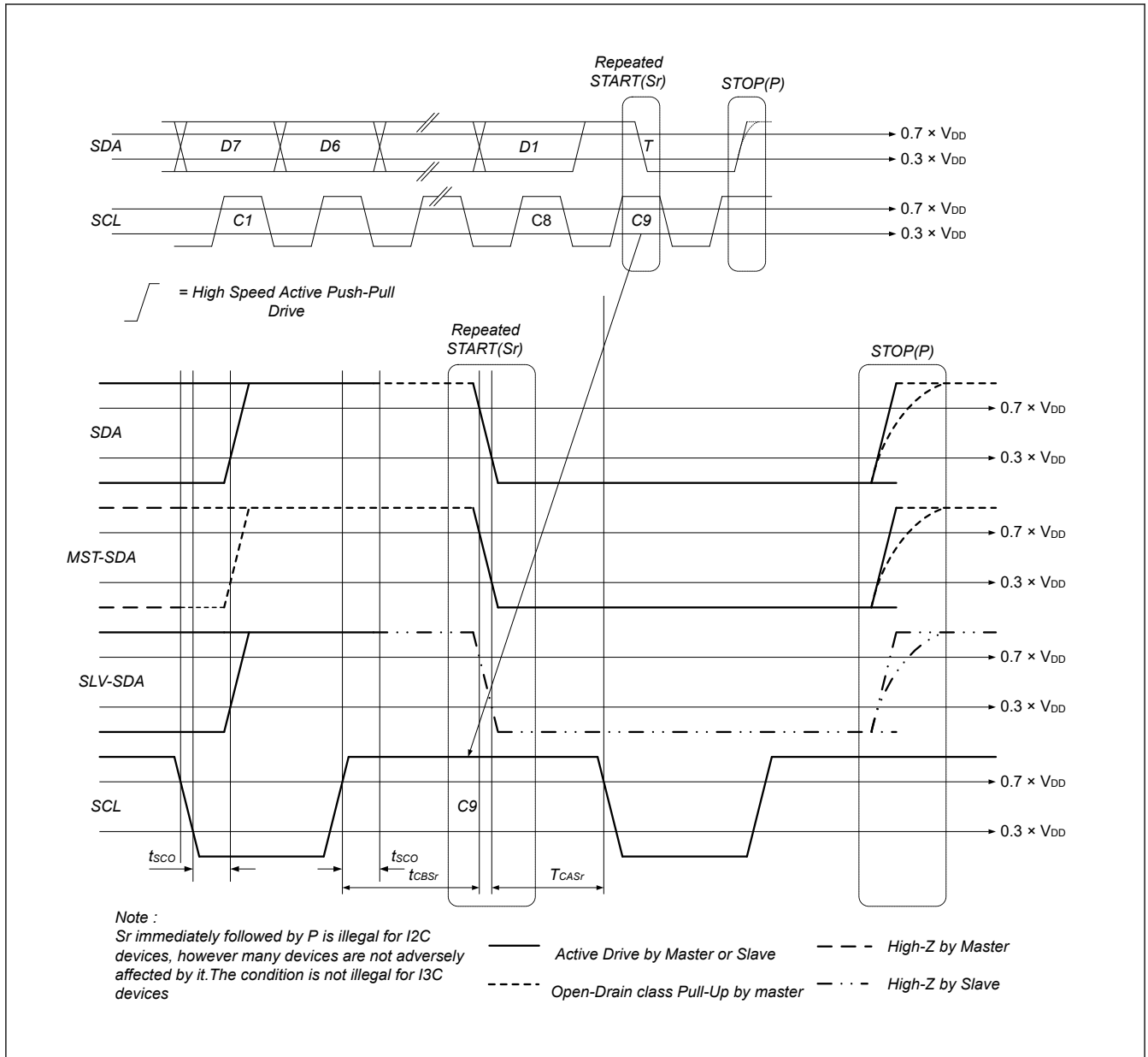

Figure 2.41 T-Bit When Master Ends Read with Repeated START and STOP

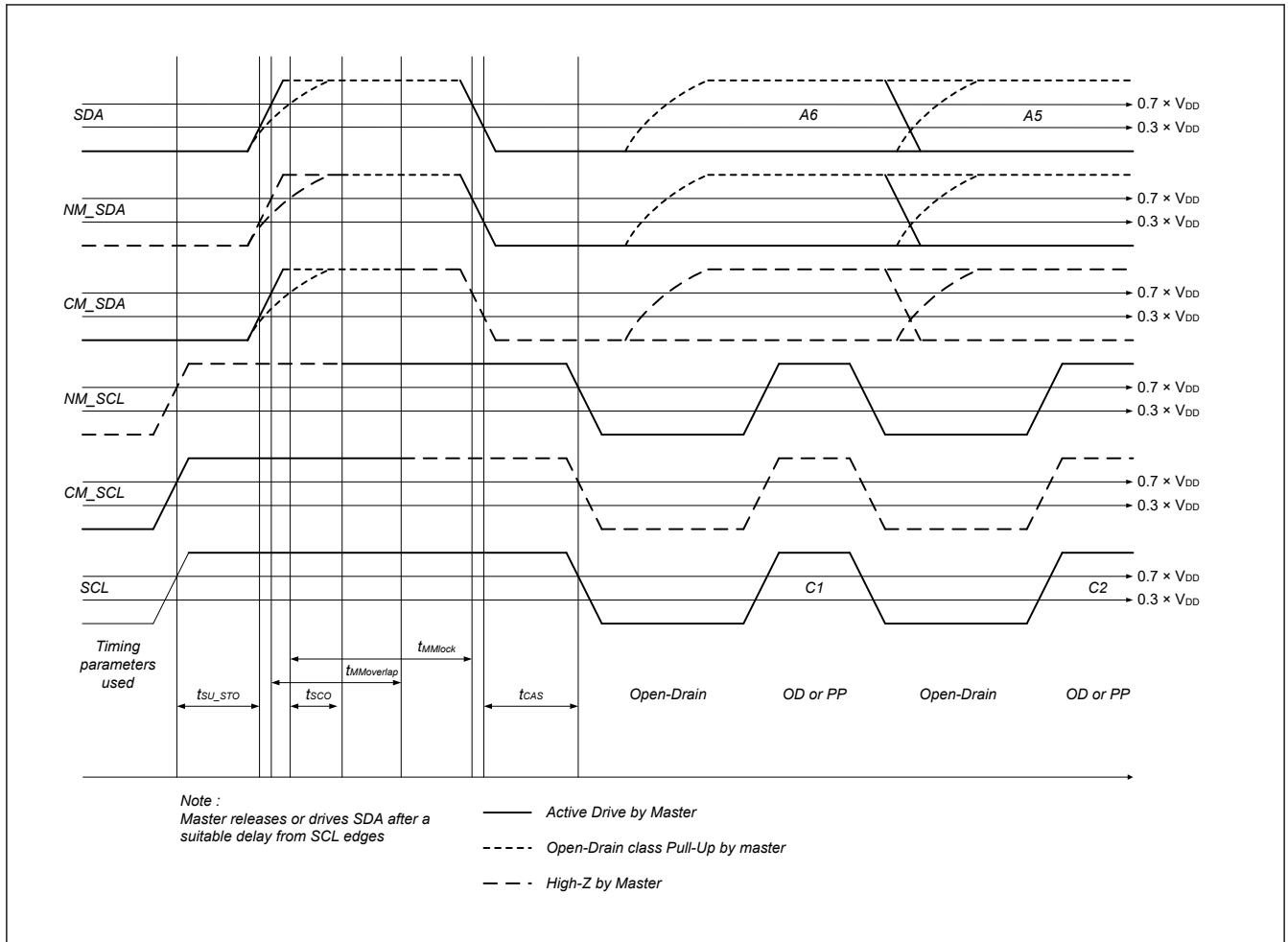

Figure 2.42 I3C Timing

2.3.11 CLKOUT Timing

Table 2.38 CLKOUT timing

Parameter	Symbol	Min	Max	Unit	Test conditions	
CLKOUT pin output cycle	t_{Cyc}	$2.7\text{ V} \leq V_{CC} \leq 5.5\text{ V}$	62.5	—	ns	Figure 2.43
		$1.8\text{ V} \leq V_{CC} < 2.7\text{ V}$	125	—		
		$1.6\text{ V} \leq V_{CC} < 1.8\text{ V}$	250	—		
CLKOUT pin high pulse width*1	t_{CH}	$2.7\text{ V} \leq V_{CC} \leq 5.5\text{ V}$	15	—	ns	
		$1.8\text{ V} \leq V_{CC} < 2.7\text{ V}$	30	—		
		$1.6\text{ V} \leq V_{CC} < 1.8\text{ V}$	150	—		
CLKOUT pin low pulse width*1	t_{CL}	$2.7\text{ V} \leq V_{CC} \leq 5.5\text{ V}$	15	—	ns	
		$1.8\text{ V} \leq V_{CC} < 2.7\text{ V}$	30	—		
		$1.6\text{ V} \leq V_{CC} < 1.8\text{ V}$	150	—		
CLKOUT pin output rise time	t_{Cr}	$2.7\text{ V} \leq V_{CC} \leq 5.5\text{ V}$	—	12	ns	
		$1.8\text{ V} \leq V_{CC} < 2.7\text{ V}$	—	25		
		$1.6\text{ V} \leq V_{CC} < 1.8\text{ V}$	—	50		
CLKOUT pin output fall time	t_{Cf}	$2.7\text{ V} \leq V_{CC} \leq 5.5\text{ V}$	—	12	ns	
		$1.8\text{ V} \leq V_{CC} < 2.7\text{ V}$	—	25		
		$1.6\text{ V} \leq V_{CC} < 1.8\text{ V}$	—	50		

Note 1. When MOCO is selected as the clock output source (the CKOCR.CKOSSEL[2:0] bits are 001b), set the clock output division ratio to be divided by 2 (the CKOCR.CKODIV[2:0] bits are 001b).

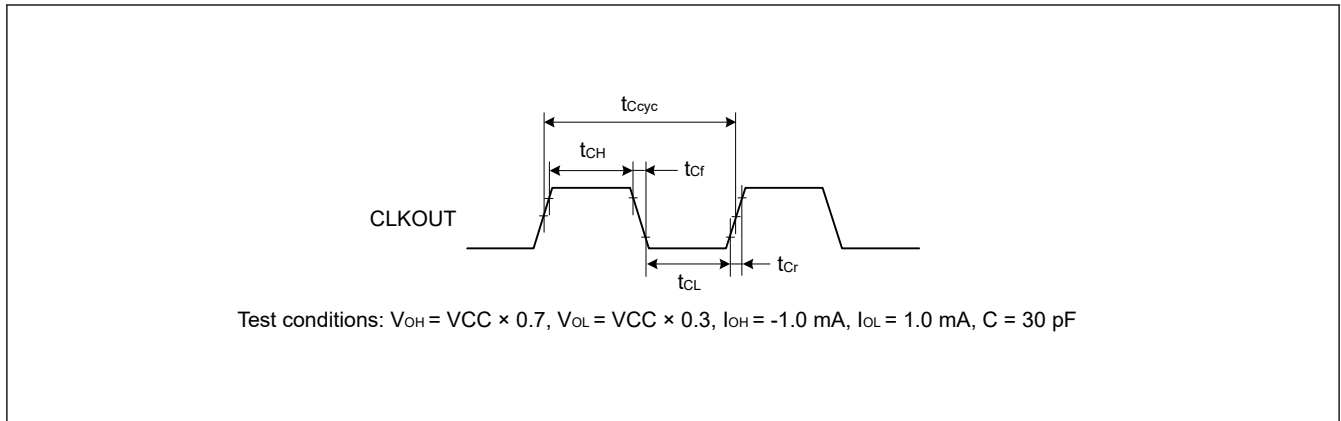

Figure 2.43 CLKOUT output timing

2.4 ADC12 Characteristics

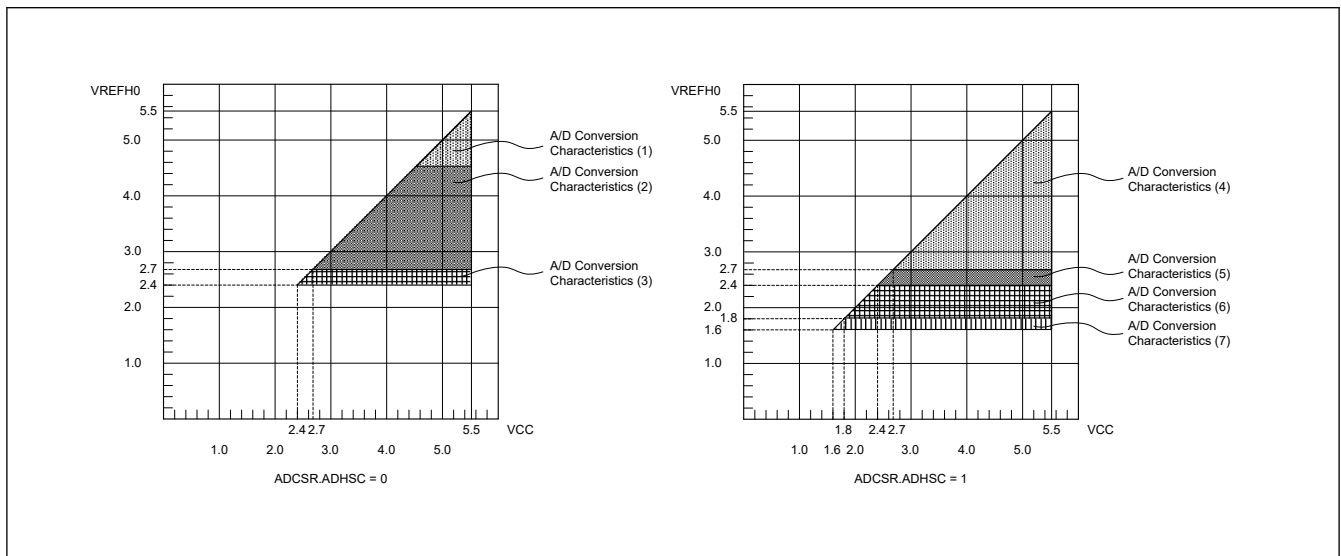

Figure 2.44 AVCC0 to VREFH0 voltage range

Table 2.39 A/D conversion characteristics (1) in high-speed A/D conversion mode (1 of 2)

Conditions: $V_{CC} = V_{REFH0} = 4.5 \text{ to } 5.5 \text{ V}^5$, $V_{SS} = V_{REFL0} = 0 \text{ V}$
 Reference voltage range applied to the VREFH0 and VREFL0.

Parameter	Min	Typ	Max	Unit	Test conditions
PCLKD (ADCLK) frequency	1	—	64	MHz	ADACSR.ADSAC = 0
			48	MHz	ADACSR.ADSAC = 1
Analog input capacitance*2	Cs	—	9^{*3}	pF	High-precision channel
			10^{*3}	pF	Normal-precision channel
Analog input resistance	Rs	—	1.3^{*3}	kΩ	High-precision channel
			5.0^{*3}	kΩ	Normal-precision channel
Analog input voltage range	Ain	0	VREFH0	V	—
Resolution	—	—	12	Bit	—

Table 2.39 A/D conversion characteristics (1) in high-speed A/D conversion mode (2 of 2)

Conditions: VCC = VREFH0 = 4.5 to 5.5 V^{*5}, VSS = VREFL0 = 0 V
Reference voltage range applied to the VREFH0 and VREFL0.

Parameter		Min	Typ	Max	Unit	Test conditions
Conversion time ^{*1} (Operation at PCLKD = 64 MHz)	Permissible signal source impedance Max. = 0.3 kΩ	0.70 (0.211) ^{*4}	—	—	μs	High-precision channel ADCSR.ADHSC = 0 ADSSTRn.SST[7:0] = 0x0D ADACSR.ADSAC = 0
		1.34 (0.852) ^{*4}	—	—	μs	Normal-precision channel ADCSR.ADHSC = 0 ADSSTRn.SST[7:0] = 0x36 ADACSR.ADSAC = 0
Conversion time ^{*1} (Operation at PCLKD = 48 MHz)	Permissible signal source impedance Max. = 0.3 kΩ	0.67 (0.219) ^{*4}	—	—	μs	High-precision channel ADCSR.ADHSC = 0 ADSSTRn.SST[7:0] = 0x0A ADACSR.ADSAC = 1
		1.29 (0.844) ^{*4}	—	—	μs	Normal-precision channel ADCSR.ADHSC = 0 ADSSTRn.SST[7:0] = 0x28 ADACSR.ADSAC = 1
Offset error		—	±1.0	±5	LSB	High-precision channel
				±6	LSB	Other than specified
Full-scale error		—	±1.0	±5	LSB	High-precision channel
				±6	LSB	Other than specified
Quantization error		—	±0.5	—	LSB	—
Absolute accuracy		—	±2.5	±5.5	LSB	High-precision channel
				±8.5	LSB	Other than specified
DNL differential nonlinearity error		—	±1.0	—	LSB	—
INL integral nonlinearity error		—	±1.5	±3.0	LSB	—

Note: The characteristics apply when no pin functions other than 12-bit A/D converter input are used. Absolute accuracy does not include quantization errors. Offset error, full-scale error, DNL differential nonlinearity error, and INL integral nonlinearity error do not include quantization errors.

Note 1. The conversion time is the sum of the sampling time and the comparison time. The number of sampling states is indicated for the test conditions.

Note 2. Except for I/O input capacitance (C_{in}), see [section 2.2.4. I/O VOH, VOL, and Other Characteristics](#).

Note 3. Reference data.

Note 4. () lists sampling time.

Note 5. When VREFH0 < AVCC0, the MAX. values are as follows.

Absolute accuracy/Offset error/Full-scale error:

For voltage difference between AVCC0 and VREFH0, it should be added ±0.75 LSB/V to the Max spec.

INL integral non-linearity error:

For voltage difference between AVCC0 and VREFH0, it should be added ±0.2 LSB/V to the Max spec.

Table 2.40 A/D conversion characteristics (2) in high-speed A/D conversion mode (1 of 2)

Conditions: VCC = VREFH0 = 2.7 to 5.5 V^{*5}, VSS = VREFL0 = 0 V
Reference voltage range applied to the VREFH0 and VREFL0.

Parameter		Min	Typ	Max	Unit	Test conditions
PCLKD (ADCLK) frequency		1	—	48	MHz	—
Analog input capacitance ^{*2}	Cs	—	—	9 ^{*3}	pF	High-precision channel
		—	—	10 ^{*3}	pF	Normal-precision channel
Analog input resistance	Rs	—	—	1.9 ^{*3}	kΩ	High-precision channel
		—	—	6.0 ^{*3}	kΩ	Normal-precision channel
Analog input voltage range	A _{in}	0	—	VREFH0	V	—
Resolution		—	—	12	Bit	—

Table 2.40 A/D conversion characteristics (2) in high-speed A/D conversion mode (2 of 2)

Conditions: VCC = VREFH0 = 2.7 to 5.5 V^{*5}, VSS = VREFL0 = 0 V
Reference voltage range applied to the VREFH0 and VREFL0.

Parameter		Min	Typ	Max	Unit	Test conditions
Conversion time ^{*1} (Operation at PCLKD = 48 MHz)	Permissible signal source impedance Max. = 0.3 kΩ	0.67 (0.219) ^{*4}	—	—	μs	High-precision channel ADCSR.ADHSC = 0 ADSSTRn.SST[7:0] = 0x0A ADACSR.ADSAC = 1
		1.29 (0.844) ^{*4}	—	—	μs	Normal-precision channel ADCSR.ADHSC = 0 ADSSTRn.SST[7:0] = 0x28 ADACSR.ADSAC = 1
Offset error		—	±1.0	±6.5	LSB	High-precision channel
				±8	LSB	Other than specified
Full-scale error		—	±1.0	±6.5	LSB	High-precision channel
				±8	LSB	Other than specified
Quantization error		—	±0.5	—	LSB	—
Absolute accuracy		—	±2.5	±7	LSB	High-precision channel
				±10	LSB	Other than specified
DNL differential nonlinearity error		—	±1.0	—	LSB	—
INL integral nonlinearity error		—	±1.5	±3.0	LSB	—

Note: The characteristics apply when no pin functions other than 12-bit A/D converter input are used. Absolute accuracy does not include quantization errors. Offset error, full-scale error, DNL differential nonlinearity error, and INL integral nonlinearity error do not include quantization errors.

Note 1. The conversion time is the sum of the sampling time and the comparison time. The number of sampling states is indicated for the test conditions.

Note 2. Except for I/O input capacitance (C_{in}), see [section 2.2.4. I/O VOH, VOL, and Other Characteristics](#).

Note 3. Reference data.

Note 4. () lists sampling time.

Note 5. When VREFH0 < AVCC0, the MAX. values are as follows.

Absolute accuracy/Offset error/Full-scale error:

For voltage difference between AVCC0 and VREFH0, it should be added ±0.75 LSB/V to the Max spec.

INL integral non-linearity error:

For voltage difference between AVCC0 and VREFH0, it should be added ±0.2 LSB/V to the Max spec.

Table 2.41 A/D conversion characteristics (3) in high-speed A/D conversion mode (1 of 2)

Conditions: VCC = VREFH0 = 2.4 to 5.5 V^{*5}, VSS = VREFL0 = 0 V
Reference voltage range applied to the VREFH0 and VREFL0.

Parameter		Min	Typ	Max	Unit	Test conditions
PCLKD (ADCLK) frequency		1	—	32	MHz	—
Analog input capacitance ^{*2}	Cs	—	—	9 ^{*3}	pF	High-precision channel
		—	—	10 ^{*3}	pF	Normal-precision channel
Analog input resistance	Rs	—	—	2.2 ^{*3}	kΩ	High-precision channel
		—	—	7.0 ^{*3}	kΩ	Normal-precision channel
Analog input voltage range	A _{in}	0	—	VREFH0	V	—
Resolution		—	—	12	Bit	—
Conversion time ^{*1} (Operation at PCLKD = 32 MHz)	Permissible signal source impedance Max. = 1.3 kΩ	1.00 (0.328) ^{*4}	—	—	μs	High-precision channel ADCSR.ADHSC = 0 ADSSTRn.SST[7:0] = 0x0A ADACSR.ADSAC = 1
		1.94 (1.266) ^{*4}	—	—	μs	Normal-precision channel ADCSR.ADHSC = 0 ADSSTRn.SST[7:0] = 0x28 ADACSR.ADSAC = 1

Table 2.41 A/D conversion characteristics (3) in high-speed A/D conversion mode (2 of 2)

Conditions: $V_{CC} = V_{REFH0} = 2.4$ to $5.5 V^{*5}$, $V_{SS} = V_{REFL0} = 0 V$
Reference voltage range applied to the V_{REFH0} and V_{REFL0} .

Parameter	Min		Max	Unit	Test conditions
Offset error	—	± 1.0	± 6.5	LSB	High-precision channel
			± 8	LSB	Other than specified
Full-scale error	—	± 1.0	± 6.5	LSB	High-precision channel
			± 8	LSB	Other than specified
Quantization error	—	± 0.5	—	LSB	—
Absolute accuracy	—	± 2.50	± 7	LSB	High-precision channel
			± 10	LSB	Other than specified
DNL differential nonlinearity error	—	± 1.0	—	LSB	—
INL integral nonlinearity error	—	± 1.5	± 3.0	LSB	—

Note: The characteristics apply when no pin functions other than 12-bit A/D converter input are used. Absolute accuracy does not include quantization errors. Offset error, full-scale error, DNL differential nonlinearity error, and INL integral nonlinearity error do not include quantization errors.

Note 1. The conversion time is the sum of the sampling time and the comparison time. The number of sampling states is indicated for the test conditions.

Note 2. Except for I/O input capacitance (C_{in}), see [section 2.2.4. I/O VOH, VOL, and Other Characteristics](#).

Note 3. Reference data.

Note 4. () lists sampling time.

Note 5. When $V_{REFH0} < AV_{CC0}$, the MAX. values are as follows.

Absolute accuracy/Offset error/Full-scale error:

For voltage difference between AV_{CC0} and V_{REFH0} , it should be added ± 0.75 LSB/V to the Max spec.

INL integral non-linearity error:

For voltage difference between AV_{CC0} and V_{REFH0} , it should be added ± 0.2 LSB/V to the Max spec.

Table 2.42 A/D conversion characteristics (4) in low-power A/D conversion mode (1 of 2)

Conditions: $V_{CC} = V_{REFH0} = 2.7$ to $5.5 V^{*5}$, $V_{SS} = V_{REFL0} = 0 V$
Reference voltage range applied to the V_{REFH0} and V_{REFL0} .

Parameter	Min	Typ	Max	Unit	Test conditions	
PCLKD (ADCLK) frequency	1	—	24	MHz	—	
Analog input capacitance ^{*2}	Cs	—	9^{*3}	pF	High-precision channel	
			10^{*3}	pF	Normal-precision channel	
Analog input resistance	Rs	—	1.9^{*3}	k Ω	High-precision channel	
			6^{*3}	k Ω	Normal-precision channel	
Analog input voltage range	Ain	0	V_{REFH0}	V	—	
Resolution	—	—	12	Bit	—	
Conversion time ^{*1} (Operation at PCLKD = 24 MHz)	Permissible signal source impedance Max. = 1.1 k Ω	1.58 (0.438) ^{*4}	—	—	μs	High-precision channel ADCSR.ADHSC = 1 ADSSTRn.SST[7:0] = 0x0A ADACSR.ADSAC = 1
		2.0 (0.854) ^{*4}	—	—	μs	Normal-precision channel ADCSR.ADHSC = 1 ADSSTRn.SST[7:0] = 0x14 ADACSR.ADSAC = 1
Offset error	—	± 1.25	± 7	LSB	High-precision channel	
			± 8.5	LSB	Other than specified	
Full-scale error	—	± 1.25	± 7	LSB	High-precision channel	
			± 8.5	LSB	Other than specified	
Quantization error	—	± 0.5	—	LSB	—	

Table 2.42 A/D conversion characteristics (4) in low-power A/D conversion mode (2 of 2)

Conditions: VCC = VREFH0 = 2.7 to 5.5 V⁵, VSS = VREFL0 = 0 V
Reference voltage range applied to the VREFH0 and VREFL0.

Parameter	Min	Typ	Max	Unit	Test conditions
Absolute accuracy	—	±3.25	±8	LSB	High-precision channel
			±11	LSB	Other than specified
DNL differential nonlinearity error	—	±1.5	—	LSB	—
INL integral nonlinearity error	—	±1.75	±4.0	LSB	—

Note: The characteristics apply when no pin functions other than 12-bit A/D converter input are used. Absolute accuracy does not include quantization errors. Offset error, full-scale error, DNL differential nonlinearity error, and INL integral nonlinearity error do not include quantization errors.

Note 1. The conversion time is the sum of the sampling time and the comparison time. The number of sampling states is indicated for the test conditions.

Note 2. Except for I/O input capacitance (C_{in}), see [section 2.2.4. I/O VOH, VOL, and Other Characteristics](#).

Note 3. Reference data.

Note 4. () lists sampling time.

Note 5. When VREFH0 < AVCC0, the MAX. values are as follows.

Absolute accuracy/Offset error/Full-scale error:

For voltage difference between AVCC0 and VREFH0, it should be added ±0.75 LSB/V to the Max spec.

INL integral non-linearity error:

For voltage difference between AVCC0 and VREFH0, it should be added ±0.2 LSB/V to the Max spec.

Table 2.43 A/D conversion characteristics (5) in low-power A/D conversion mode

Conditions: VCC = VREFH0 = 2.4 to 5.5 V⁵, VSS = VREFL0 = 0 V
Reference voltage range applied to the VREFH0 and VREFL0.

Parameter	Min	Typ	Max	Unit	Test conditions	
PCLKD (ADCLK) frequency	1	—	16	MHz	—	
Analog input capacitance*2	Cs	—	9*3	pF	High-precision channel	
			10*3	pF	Normal-precision channel	
Analog input resistance	Rs	—	2.2*3	kΩ	High-precision channel	
			7*3	kΩ	Normal-precision channel	
Analog input voltage range	Ain	0	VREFH0	V	—	
Resolution	—	—	12	Bit	—	
Conversion time*1 (Operation at PCLKD = 16 MHz)	Permissible signal source impedance Max. = 2.2 kΩ	2.38 (0.656)*4	—	—	μs	High-precision channel ADCSR.ADHSC = 1 ADSSTRn.SST[7:0] = 0x0A ADACSR.ADSAC = 1
		3.0 (1.281)*4	—	—	μs	Normal-precision channel ADCSR.ADHSC = 1 ADSSTRn.SST[7:0] = 0x14 ADACSR.ADSAC = 1
Offset error	—	±1.25	±7	LSB	High-precision channel	
			±8.5	LSB	Other than specified	
Full-scale error	—	±1.25	±7	LSB	High-precision channel	
			±8.5	LSB	Other than specified	
Quantization error	—	±0.5	—	LSB	—	
Absolute accuracy	—	±3.25	±8	LSB	High-precision channel	
			±11	LSB	Other than specified	
DNL differential nonlinearity error	—	±1.5	—	LSB	—	
INL integral nonlinearity error	—	±1.75	±4.0	LSB	—	

Note: The characteristics apply when no pin functions other than 12-bit A/D converter input are used. Absolute accuracy does not include quantization errors. Offset error, full-scale error, DNL differential nonlinearity error, and INL integral nonlinearity error do not include quantization errors.

- Note 1. The conversion time is the sum of the sampling time and the comparison time. The number of sampling states is indicated for the test conditions.
- Note 2. Except for I/O input capacitance (C_{in}), see [section 2.2.4. I/O VOH, VOL, and Other Characteristics](#).
- Note 3. Reference data.
- Note 4. () lists sampling time.
- Note 5. When VREFH0 < AVCC0, the MAX. values are as follows.
 Absolute accuracy/Offset error/Full-scale error:
 For voltage difference between AVCC0 and VREFH0, it should be added ±0.75 LSB/V to the Max spec.
 INL integral non-linearity error:
 For voltage difference between AVCC0 and VREFH0, it should be added ±0.2 LSB/V to the Max spec.

Table 2.44 A/D conversion characteristics (6) in low-power A/D conversion mode

Conditions: VCC = VREFH0 = 1.8 to 5.5 V⁵, VSS = VREFL0 = 0 V
 Reference voltage range applied to the VREFH0 and VREFL0.

Parameter		Min	Typ	Max	Unit	Test conditions
PCLKD (ADCLK) frequency		1	—	8	MHz	—
Analog input capacitance ^{*2}	Cs	—	—	9 ^{*3}	pF	High-precision channel
		—	—	10 ^{*3}	pF	Normal-precision channel
Analog input resistance	Rs	—	—	6 ^{*3}	kΩ	High-precision channel
		—	—	14 ^{*3}	kΩ	Normal-precision channel
Analog input voltage range	Ain	0	—	VREFH0	V	—
Resolution		—	—	12	Bit	—
Conversion time ^{*1} (Operation at PCLKD = 8 MHz)	Permissible signal source impedance Max. = 5 kΩ	4.75 (1.313) ^{*4}	—	—	μs	High-precision channel ADCSR.ADHSC = 1 ADSSTRn.SST[7:0] = 0x0A ADACSR.ADSAC = 1
		6.0 (2.563) ^{*4}	—	—	μs	Normal-precision channel ADCSR.ADHSC = 1 ADSSTRn.SST[7:0] = 0x14 ADACSR.ADSAC = 1
Offset error		—	±1.25	±8.5	LSB	High-precision channel
				±11	LSB	Other than specified
Full-scale error		—	±1.5	±8.5	LSB	High-precision channel
				±11	LSB	Other than specified
Quantization error		—	±0.5	—	LSB	—
Absolute accuracy		—	±3.75	±10.5	LSB	High-precision channel
				±14.5	LSB	Other than specified
DNL differential nonlinearity error		—	±2.0	—	LSB	—
INL integral nonlinearity error		—	±2.25	±4.5	LSB	—

Note: The characteristics apply when no pin functions other than 12-bit A/D converter input are used. Absolute accuracy does not include quantization errors. Offset error, full-scale error, DNL differential nonlinearity error, and INL integral nonlinearity error do not include quantization errors.

- Note 1. The conversion time is the sum of the sampling time and the comparison time. The number of sampling states is indicated for the test conditions.
- Note 2. Except for I/O input capacitance (C_{in}), see [section 2.2.4. I/O VOH, VOL, and Other Characteristics](#).
- Note 3. Reference data.
- Note 4. () lists sampling time.
- Note 5. When VREFH0 < AVCC0, the MAX. values are as follows.
 Absolute accuracy/Offset error/Full-scale error:
 For voltage difference between AVCC0 and VREFH0, it should be added ±0.75 LSB/V to the Max spec.
 INL integral non-linearity error:
 For voltage difference between AVCC0 and VREFH0, it should be added ±0.2 LSB/V to the Max spec.

Table 2.45 A/D conversion characteristics (7) in low-power A/D conversion mode

Conditions: VCC = VREFH0 = 1.6 to 5.5 V^{*5}, VSS = VREFL0 = 0 V
Reference voltage range applied to the VREFH0 and VREFL0.

Parameter		Min	Typ	Max	Unit	Test conditions
PCLKD (ADCLK) frequency		1	—	4	MHz	—
Analog input capacitance ^{*2}	Cs	—	—	9 ^{*3}	pF	High-precision channel
		—	—	10 ^{*3}	pF	Normal-precision channel
Analog input resistance	Rs	—	—	12 ^{*3}	kΩ	High-precision channel
		—	—	28 ^{*3}	kΩ	Normal-precision channel
Analog input voltage range	Ain	0	—	VREFH0	V	—
Resolution		—	—	12	Bit	—
Conversion time ^{*1} (Operation at PCLKD = 4 MHz)	Permissible signal source impedance Max. = 9.9 kΩ	9.5 (2.625) ^{*4}	—	—	μs	High-precision channel ADCSR.ADHSC = 1 ADSSTRn.SST[7:0] = 0x0A ADACSR.ADSAC = 1
		12.0 (5.125) ^{*4}	—	—	μs	Normal-precision channel ADCSR.ADHSC = 1 ADSSTRn.SST[7:0] = 0x14 ADACSR.ADSAC = 1
Offset error		—	±1.25	±8.5	LSB	High-precision channel
				±11	LSB	Other than specified
Full-scale error		—	±1.5	±8.5	LSB	High-precision channel
				±11	LSB	Other than specified
Quantization error		—	±0.5	—	LSB	—
Absolute accuracy		—	±3.75	±10.5	LSB	High-precision channel
				±14.5	LSB	Other than specified
DNL differential nonlinearity error		—	±2.0	—	LSB	—
INL integral nonlinearity error		—	±2.25	±4.5	LSB	—

Note: The characteristics apply when no pin functions other than 12-bit A/D converter input are used. Absolute accuracy does not include quantization errors. Offset error, full-scale error, DNL differential nonlinearity error, and INL integral nonlinearity error do not include quantization errors.

Note 1. The conversion time is the sum of the sampling time and the comparison time. The number of sampling states is indicated for the test conditions.

Note 2. Except for I/O input capacitance (Cin), see [section 2.2.4. I/O VOH, VOL, and Other Characteristics](#).

Note 3. Reference data.

Note 4. () lists sampling time.

Note 5. When VREFH0 < AVCC0, the MAX. values are as follows.

Absolute accuracy/Offset error/Full-scale error:

For voltage difference between AVCC0 and VREFH0, it should be added ±0.75 LSB/V to the Max spec.

INL integral non-linearity error:

For voltage difference between AVCC0 and VREFH0, it should be added ±0.2 LSB/V to the Max spec.

Figure 2.45 shows the equivalent circuit for analog input.

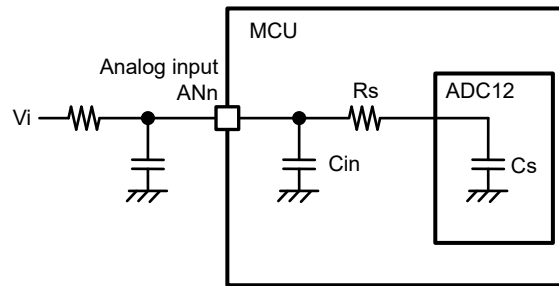

Note: Terminal leakage current is not shown in this figure.

Figure 2.45 Equivalent circuit for analog input

Table 2.46 12-bit A/D converter channel classification

Classification	Channel	Conditions	Remarks
High-precision channel	AN005, AN006, AN009, AN010	AVCC0 = 1.6 to 5.5 V	Pins AN005, AN006, AN009, AN010 cannot be used as general I/O, TS transmission, when the A/D converter is in use.
Normal-precision channel	AN019 to AN022		
Internal reference voltage input channel	Internal reference voltage	AVCC0 = 1.8 to 5.5 V	—
Temperature sensor input channel	Temperature sensor output	AVCC0 = 1.8 to 5.5 V	—

Table 2.47 A/D internal reference voltage characteristics

Conditions: VCC = VREFH0 = 1.8 to 5.5 V*1

Parameter	Min	Typ	Max	Unit	Test conditions
Internal reference voltage input channel*2	1.42	1.48	1.54	V	—
PCLKD (ADCLK) frequency*3	1	—	2	MHz	—
Sampling time*4	5.0	—	—	μs	—

Note 1. The internal reference voltage cannot be selected for input channels when AVCC0 < 1.8 V.

Note 2. The 12-bit A/D internal reference voltage indicates the voltage when the internal reference voltage is input to the 12-bit A/D converter.

Note 3. When the internal reference voltage is selected as the high-potential reference voltage.

Note 4. When the internal reference voltage is converted.

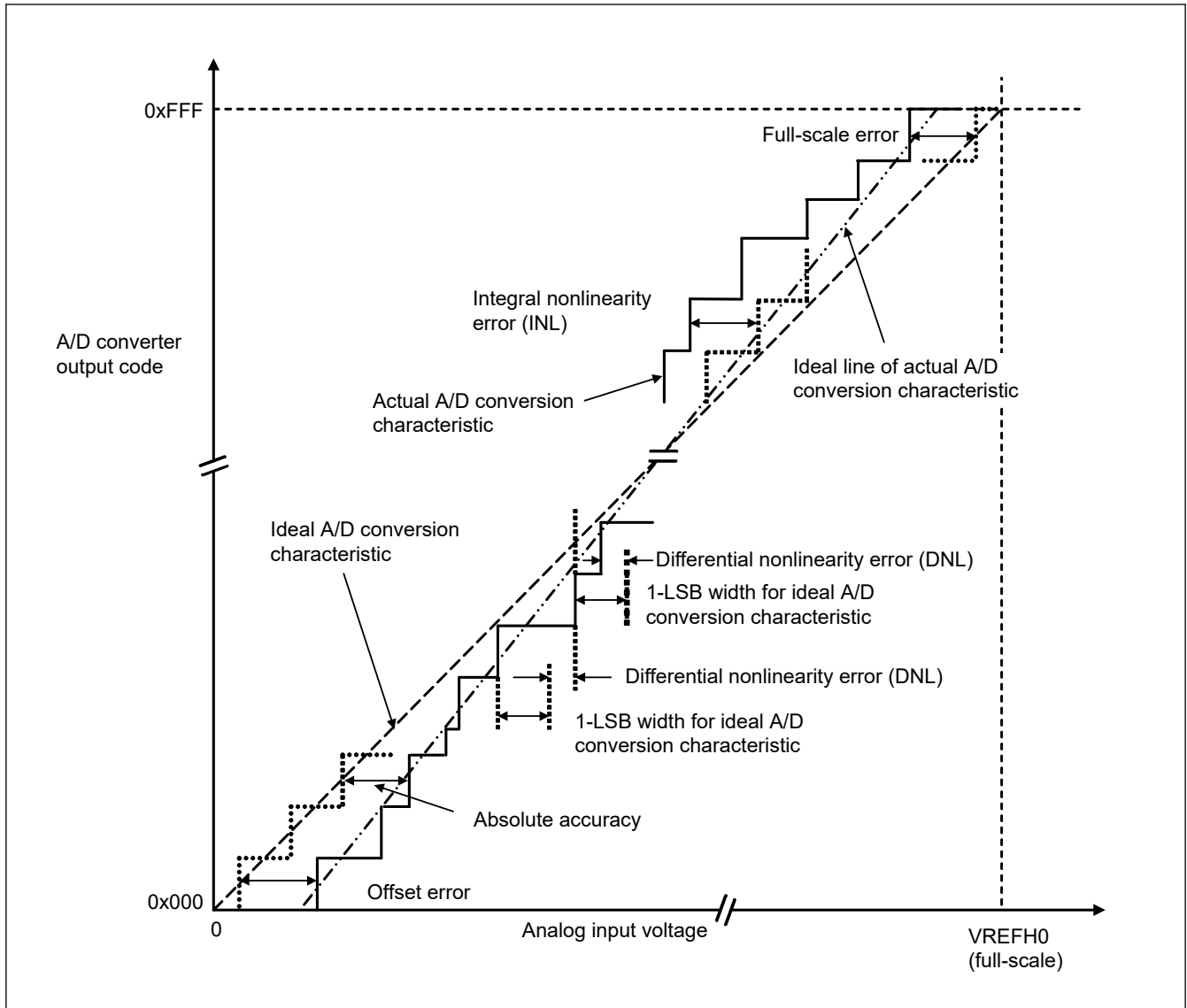

Figure 2.46 Illustration of 12-bit A/D converter characteristic terms

Absolute accuracy

Absolute accuracy is the difference between output code based on the theoretical A/D conversion characteristics, and the actual A/D conversion result. When measuring absolute accuracy, the voltage at the midpoint of the width of the analog input voltage (1-LSB width), which can meet the expectation of outputting an equal code based on the theoretical A/D conversion characteristics, is used as the analog input voltage. For example, if 12-bit resolution is used and the reference voltage $V_{REFH0} = 3.072$ V, then 1-LSB width becomes 0.75 mV, and 0 mV, 0.75 mV, and 1.5 mV are used as the analog input voltages. If analog input voltage is 6 mV, an absolute accuracy of ± 5 LSB means that the actual A/D conversion result is in the range of 0x003 to 0x00D, though an output code of 0x008 can be expected from the theoretical A/D conversion characteristics.

Integral nonlinearity error (INL)

Integral nonlinearity error is the maximum deviation between the ideal line when the measured offset and full-scale errors are zeroed, and the actual output code.

Differential nonlinearity error (DNL)

Differential nonlinearity error is the difference between 1-LSB width based on the ideal A/D conversion characteristics and the width of the actual output code.

Offset error

Offset error is the difference between the transition point of the ideal first output code and the actual first output code.

Full-scale error

Full-scale error is the difference between the transition point of the ideal last output code and the actual last output code.

2.5 TSN Characteristics

Table 2.48 TSN characteristics

Conditions: VCC = 1.8 to 5.5 V

Parameter	Symbol	Min	Typ	Max	Unit	Test conditions
Relative accuracy	—	—	± 1.5	—	°C	2.4 V or above
		—	± 2.0	—	°C	Below 2.4 V
Temperature slope	—	—	-3.3	—	mV/°C	—
Output voltage (at 25°C)	—	—	1.05	—	V	VCC = 3.3 V
Temperature sensor start time	t _{START}	—	—	5	μs	—
Sampling time	—	5	—	—	μs	

2.6 POR and LVD Characteristics

Table 2.49 Power-on reset circuit and voltage detection circuit characteristics (1) (1 of 2)

Parameter			Symbol	Min	Typ	Max	Unit	Test Conditions	
Voltage detection level*1	Power-on reset (POR)	When power supply rise	V _{POR}	1.47	1.51	1.55	V	Figure 2.47	
		When power supply fall	V _{PDR}	1.46	1.50	1.54		Figure 2.48	
	Voltage detection circuit (LVD0)*2	When power supply rise	When power supply rise	V _{det0_0}	3.74	3.91	4.06	V	Figure 2.49 At falling edge VCC
					3.68	3.85	4.00		
		When power supply fall	When power supply rise	V _{det0_1}	2.73	2.9	3.01		
					2.68	2.85	2.96		
		When power supply rise	When power supply fall	V _{det0_2}	2.44	2.59	2.70		
					2.38	2.53	2.64		
		When power supply rise	When power supply fall	V _{det0_3}	1.83	1.95	2.07		
					1.78	1.90	2.02		
		When power supply rise	When power supply fall	V _{det0_4}	1.66	1.75	1.88		
					1.60	1.69	1.82		

Table 2.49 Power-on reset circuit and voltage detection circuit characteristics (1) (2 of 2)

Parameter	Symbol	Min	Typ	Max	Unit	Test Conditions		
Voltage detection level*1	Voltage detection circuit (LVD1)*3	When power supply rise	V _{det1_0}	4.23	4.39	4.55	V	Figure 2.50 At falling edge VCC
		When power supply fall		4.13	4.29	4.45		
		When power supply rise	V _{det1_1}	4.07	4.25	4.39		
		When power supply fall		3.98	4.16	4.30		
		When power supply rise	V _{det1_2}	3.97	4.14	4.29		
		When power supply fall		3.86	4.03	4.18		
		When power supply rise	V _{det1_3}	3.74	3.92	4.06		
		When power supply fall		3.68	3.86	4.00		
		When power supply rise	V _{det1_4}	3.05	3.17	3.29		
		When power supply fall		2.98	3.10	3.22		
		When power supply rise	V _{det1_5}	2.95	3.06	3.17		
		When power supply fall		2.89	3.00	3.11		
		When power supply rise	V _{det1_6}	2.86	2.97	3.08		
		When power supply fall		2.79	2.90	3.01		
		When power supply rise	V _{det1_7}	2.74	2.85	2.96		
		When power supply fall		2.68	2.79	2.90		
Voltage detection level*1	Voltage detection circuit (LVD1)*3	When power supply rise	V _{det1_8}	2.63	2.75	2.85	V	Figure 2.50 At falling edge VCC
		When power supply fall		2.58	2.68	2.78		
		When power supply rise	V _{det1_9}	2.54	2.64	2.75		
		When power supply fall		2.48	2.58	2.68		
		When power supply rise	V _{det1_A}	2.43	2.53	2.63		
		When power supply fall		2.38	2.48	2.58		
		When power supply rise	V _{det1_B}	2.16	2.26	2.36		
		When power supply fall		2.10	2.20	2.30		
		When power supply rise	V _{det1_C}	1.88	2	2.09		
		When power supply fall		1.84	1.96	2.05		
		When power supply rise	V _{det1_D}	1.78	1.9	1.99		
		When power supply fall		1.74	1.86	1.95		
		When power supply rise	V _{det1_E}	1.67	1.79	1.88		
		When power supply fall		1.63	1.75	1.84		
		When power supply rise	V _{det1_F}	1.65	1.7	1.78		
		When power supply fall		1.60	1.65	1.73		
Voltage detection level*1	Voltage detection circuit (LVD2)*4	When power supply rise	V _{det2_0}	4.20	4.40	4.57	V	Figure 2.51 At falling edge VCC
		When power supply fall		4.11	4.31	4.48		
		When power supply rise	V _{det2_1}	4.05	4.25	4.42		
		When power supply fall		3.97	4.17	4.34		
		When power supply rise	V _{det2_2}	3.91	4.11	4.28		
		When power supply fall		3.83	4.03	4.20		
		When power supply rise	V _{det2_3}	3.71	3.91	4.08		
		When power supply fall		3.64	3.84	4.01		

Note 1. These characteristics apply when noise is not superimposed on the power supply. When a setting causes this voltage detection level to overlap with that of the voltage detection circuit, it cannot be specified whether LVD1 or LVD2 is used for voltage detection.

Note 2. # in the symbol V_{det0_#} denotes the value of the OFS1.VDSEL0[2:0] bits.

Note 3. # in the symbol $V_{det1_#}$ denotes the value of the LVDLVLRLVD1LVL[4:0] bits.

Note 4. # in the symbol $V_{det2_#}$ denotes the value of the LVDLVLRLVD2LVL[2:0] bits.

Table 2.50 Power-on reset circuit and voltage detection circuit characteristics (2)

Parameter	Symbol	Min	Typ	Max	Unit	Test Conditions	
Wait time after power-on reset cancellation	LVD0: enable	t_{POR}	—	4.3	—	ms	—
	LVD0: disable	t_{POR}	—	3.7	—	ms	—
Wait time after voltage monitor 0, 1, 2 reset cancellation	LVD0: enable* ¹	$t_{LVD0,1,2}$	—	1.4	—	ms	—
	LVD0: disable* ²	$t_{LVD1,2}$	—	0.7	—	ms	—
Power-on reset response delay time* ³	t_{det}	—	—	500	—	μ s	Figure 2.47, Figure 2.48
LVD0 response delay time* ³	t_{det}	—	—	500	—	μ s	Figure 2.49
LVD1 response delay time* ³	t_{det}	—	—	350	—	μ s	Figure 2.50
LVD2 response delay time* ³	t_{det}	—	—	600	—	μ s	Figure 2.51
Minimum VCC down time	$t_{V_{OFF}}$	500	—	—	—	μ s	Figure 2.47, VCC = 1.0 V or above
Power-on reset enable time	t_W (POR)	1	—	—	—	ms	Figure 2.48, VCC = below 1.0 V
LVD1 operation stabilization time (after LVD1 is enabled)	T_d (E-A)	—	—	300	—	μ s	Figure 2.50
LVD2 operation stabilization time (after LVD2 is enabled)	T_d (E-A)	—	—	1200	—	μ s	Figure 2.51
Hysteresis width (POR)	V_{PORH}	—	10	—	—	mV	—
Hysteresis width (LVD0, LVD1 and LVD2)	V_{LVH}	—	60	—	mV	LVD0 selected	
		—	110	—		V_{det1_0} to V_{det1_2} selected	
		—	70	—		V_{det1_3} to V_{det1_g} selected	
		—	60	—		V_{det1_A} to V_{det1_B} selected	
		—	50	—		V_{det1_C} to V_{det1_F} selected	
		—	90	—		LVD2 selected	

Note 1. When OFS1.LVDAS = 0.

Note 2. When OFS1.LVDAS = 1.

Note 3. The minimum VCC down time indicates the time when VCC is below the minimum value of voltage detection levels V_{POR} , V_{det0} , V_{det1} , and V_{det2} for the POR/LVD.

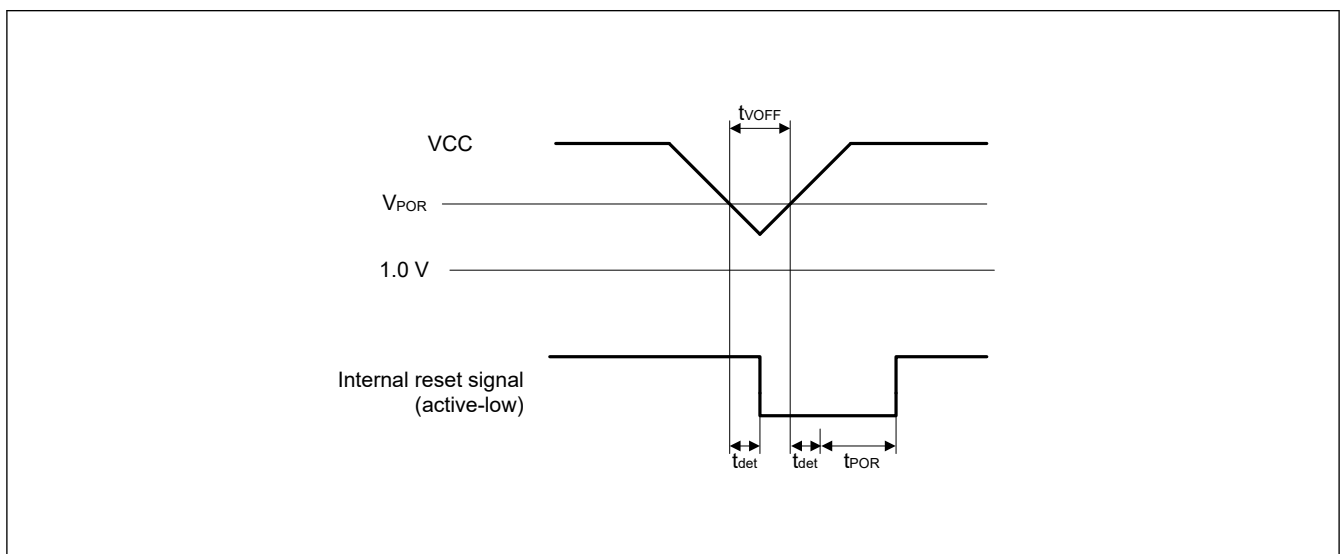

Figure 2.47 Voltage detection reset timing

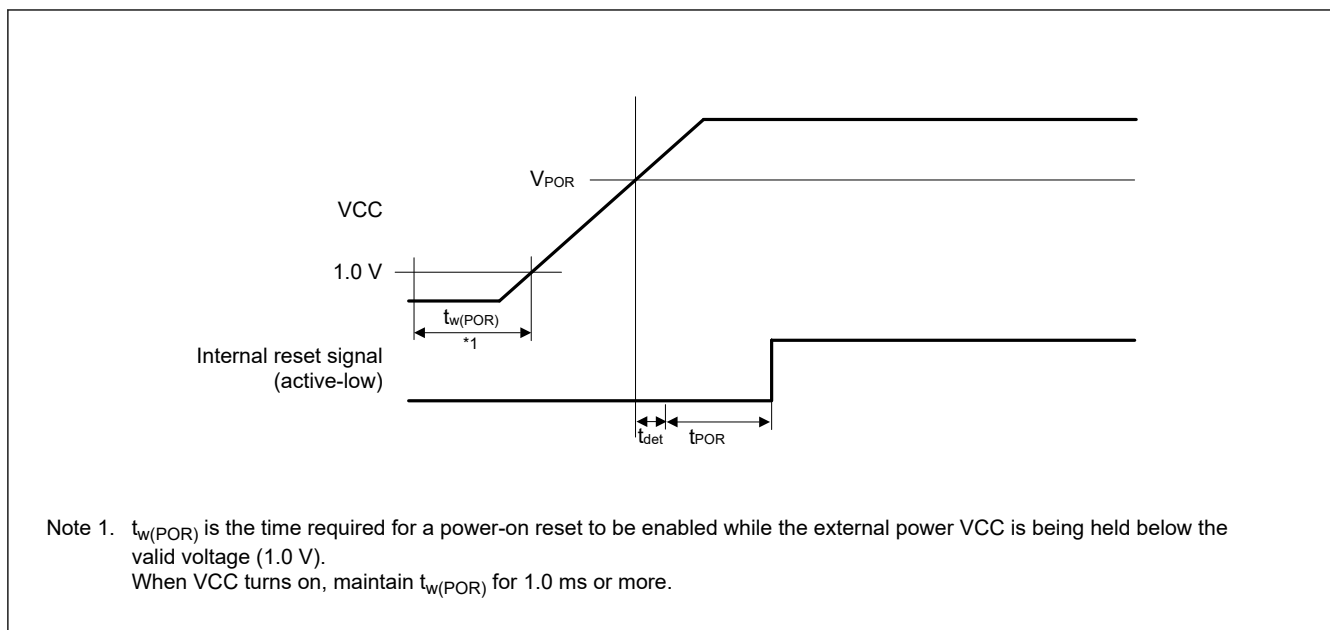

Figure 2.48 Power-on reset timing

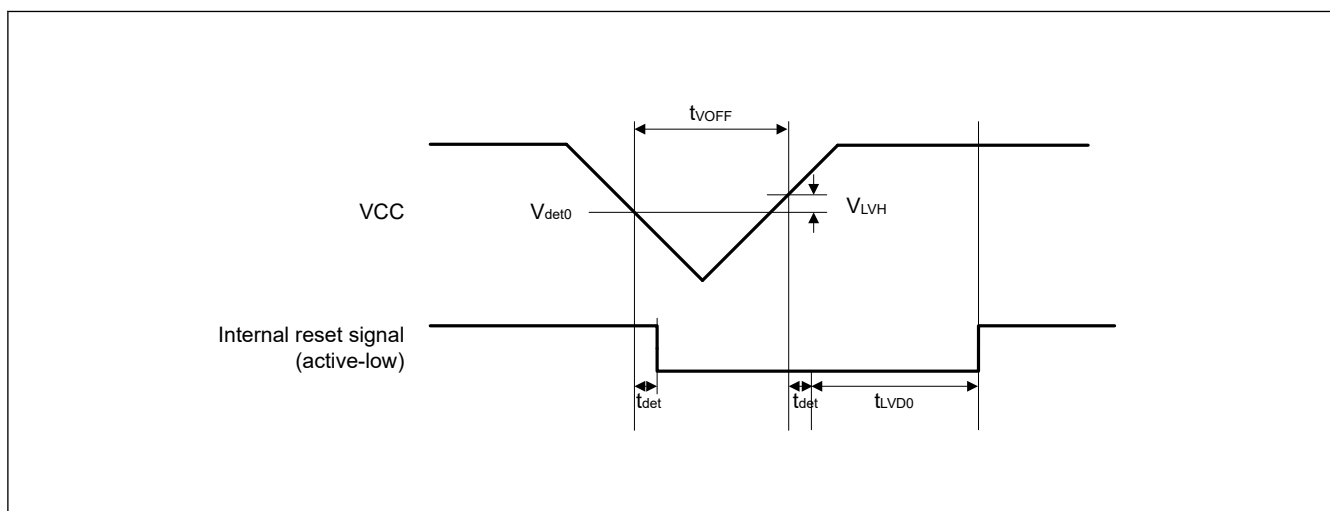

Figure 2.49 Voltage detection circuit timing (V_{det0})

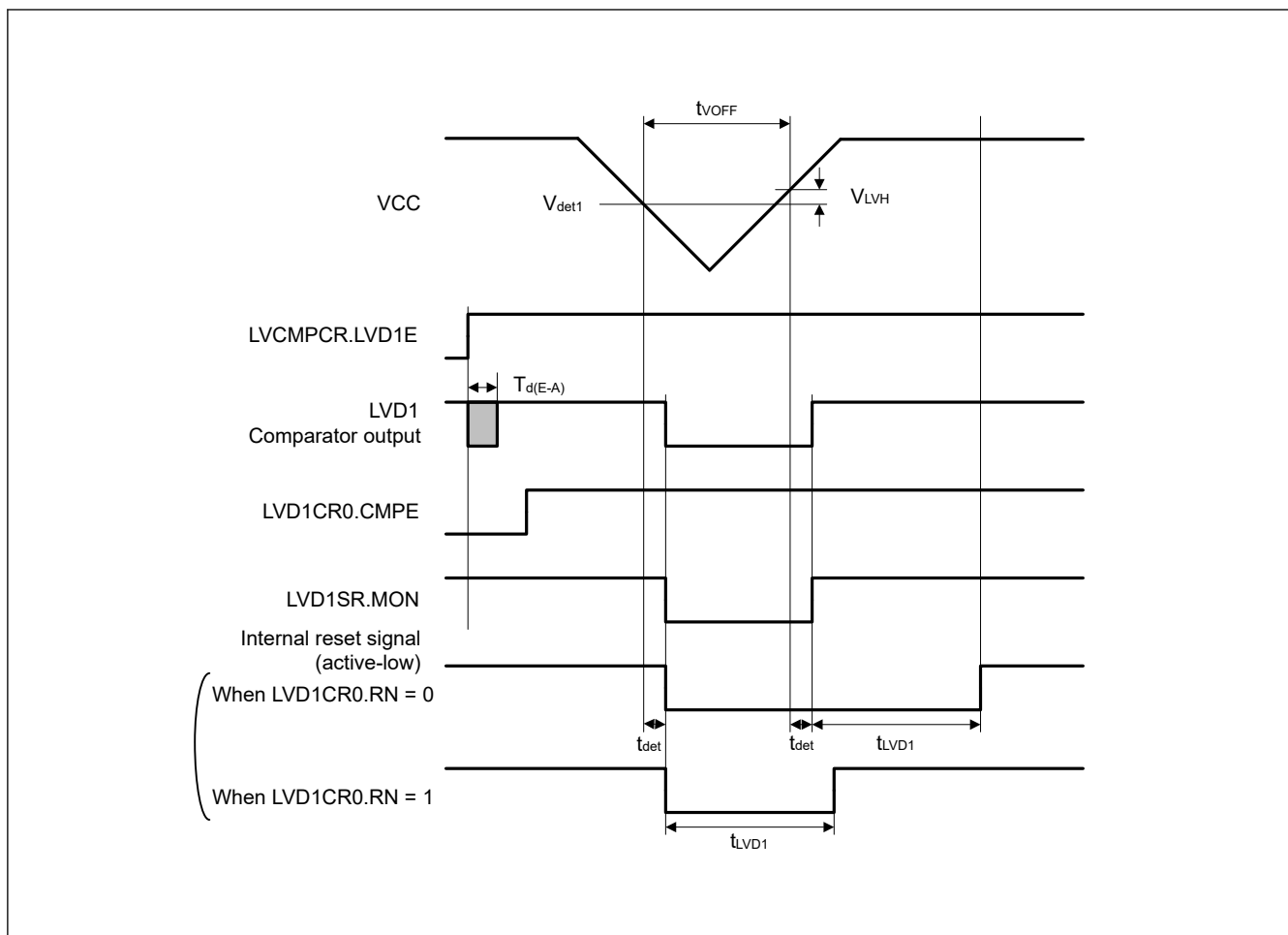

Figure 2.50 Voltage detection circuit timing (V_{det1})

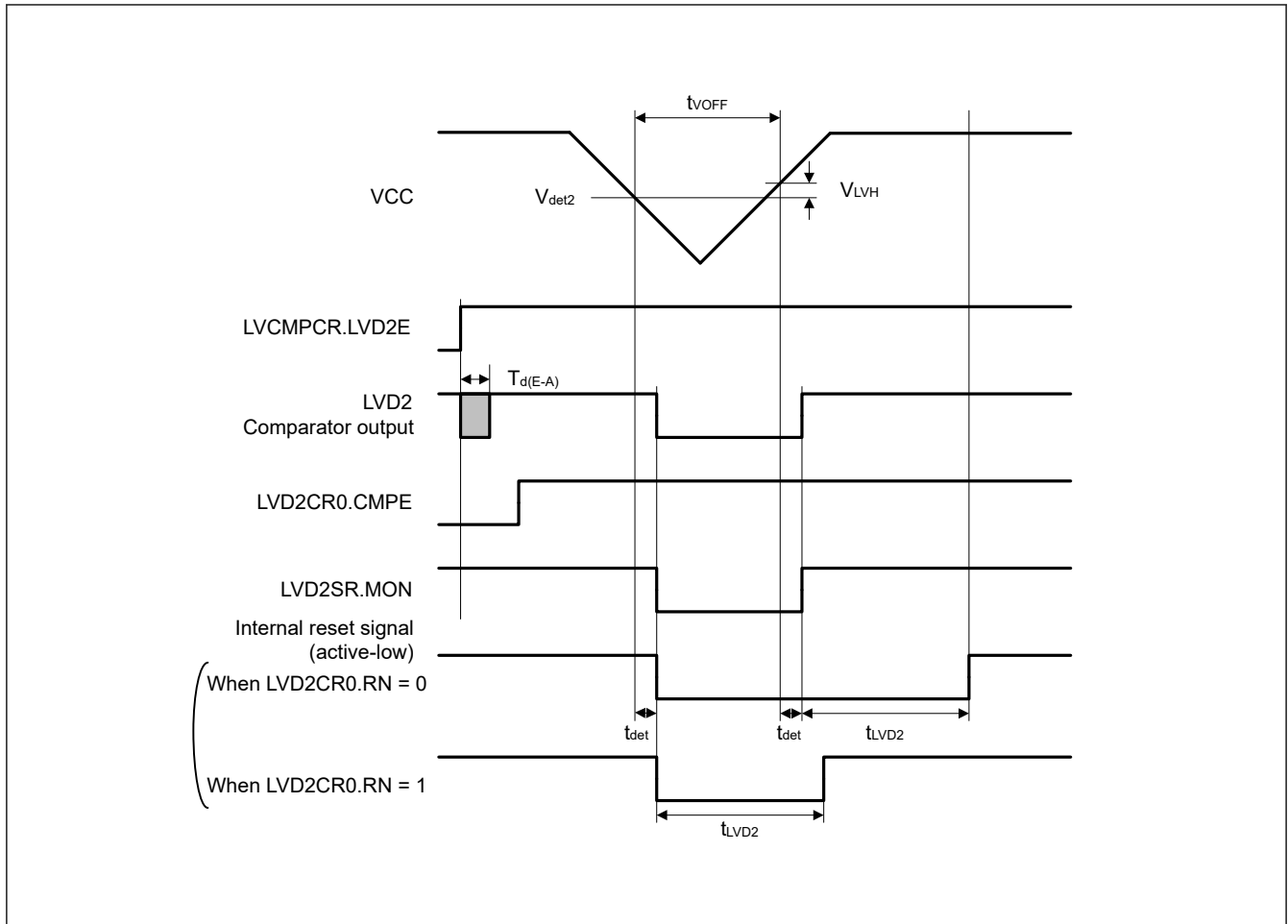

Figure 2.51 Voltage detection circuit timing (V_{det2})

2.7 Flash Memory Characteristics

2.7.1 Code Flash Memory Characteristics

Table 2.51 Code flash characteristics (1)

Parameter	Symbol	Min	Typ	Max	Unit	Conditions
Reprogramming/erasure cycle*1	N_{PEC}	1000	—	—	Times	—
Data hold time	After 1000 times N_{PEC}	t_{DRP}	20^{*2} *3	—	Year	$T_a = +105^{\circ}C$
			10	—		$T_a = +125^{\circ}C$

Note 1. The reprogram/erase cycle is the number of erasures for each block. When the reprogram/erase cycle is n times ($n = 1,000$), erasing can be performed n times for each block. For instance, when 4-byte programming is performed 512 times for different addresses in 2-KB blocks, and then the entire block is erased, the reprogram/erase cycle is counted as one. However, programming the same address for several times as one erasure is not enabled (overwriting is prohibited).

Note 2. Characteristic when using the flash memory programmer and the self-programming library provided by Renesas Electronics.

Note 3. This result is target spec, may be changed after reliability testing.

Table 2.52 Code flash characteristics (2) (1 of 2)

High-speed operating mode
Conditions: $V_{CC} = 1.8$ to 5.5 V

Parameter	Symbol	ICLK = 1 MHz			ICLK = 48 MHz			Unit	
		Min	Typ	Max	Min	Typ	Max		
Programming time	4-byte	t_{P4}	—	86	732	—	34	321	μs
Erasure time	2-KB	t_{E2K}	—	12.5	355	—	5.6	215	ms

Table 2.52 Code flash characteristics (2) (2 of 2)

High-speed operating mode
Conditions: VCC = 1.8 to 5.5 V

Parameter		Symbol	ICLK = 1 MHz			ICLK = 48 MHz			Unit
			Min	Typ	Max	Min	Typ	Max	
Blank check time	4-byte	t _{BC4}	—	—	46.5	—	—	8.3	μs
	2-KB	t _{BC2K}	—	—	3681	—	—	240	μs
Erase suspended time		t _{SED}	—	—	22.3	—	—	10.5	μs
Access window information program Start-up area selection and security setting time		t _{AWSSAS}	—	21.2	570	—	11.4	423	ms
OCD/serial programmer ID setting time*1		t _{OSIS}	—	84.7	2280	—	45.3	1690	ms
Flash memory mode transition wait time 1		t _{DIS}	2	—	—	2	—	—	μs
Flash memory mode transition wait time 2		t _{MS}	15	—	—	15	—	—	μs

Note: Does not include the time until each operation of the flash memory is started after instructions are executed by software.

Note: The lower-limit frequency of ICLK is 1 MHz during programming or erasing the flash memory. When using ICLK at below 4 MHz, the frequency can be set to 1 MHz, 2 MHz, or 3 MHz. A non-integer frequency such as 1.5 MHz cannot be set.

Note: The frequency accuracy of ICLK must be ± 1.0% during programming or erasing the flash memory. Confirm the frequency accuracy of the clock source.

Note 1. Total time of four commands.

Table 2.53 Code flash characteristics (3)

Middle-speed operating mode
Conditions: VCC = to 5.5 V

Parameter		Symbol	ICLK = 1 MHz			ICLK = MHz*2			Unit
			Min	Typ	Max	Min	Typ	Max	
Programming time	4-byte	t _{P4}	—	86	732	—	39	356	μs
Erasure time	2-KB	t _{E2K}	—	12.5	355	—	6.2	227	ms
Blank check time	4-byte	t _{BC4}	—	—	46.5	—	—	11.3	μs
	2-KB	t _{BC2K}	—	—	3681	—	—	534	μs
Erase suspended time		t _{SED}	—	—	22.3	—	—	11.7	μs
Access window information program Start-up area selection and security setting time		t _{AWSSAS}	—	21.2	570	—	12.2	435	ms
OCD/serial programmer ID setting time*1		t _{OSIS}	—	84.7	2280	—	48.7	1740	ms
Flash memory mode transition wait time 1		t _{DIS}	2	—	—	2	—	—	μs
Flash memory mode transition wait time 2		t _{MS}	15	—	—	15	—	—	μs

Note: Does not include the time until each operation of the flash memory is started after instructions are executed by software.

Note: The lower-limit frequency of ICLK is 1 MHz during programming or erasing the flash memory. When using ICLK at below 4 MHz, the frequency can be set to 1 MHz, 2 MHz, or 3 MHz. A non-integer frequency such as 1.5 MHz cannot be set.

Note: The frequency accuracy of ICLK must be ± 1.0% during programming or erasing the flash memory. Confirm the frequency accuracy of the clock source.

Note 1. Total time of four commands.

Note 2. When 1.8 V ≤ VCC ≤ 5.5 V

Table 2.54 Code flash characteristics (4)

Low-speed operating mode
Conditions: VCC = 1.6 to 5.5 V

Parameter		Symbol	ICLK = 1 MHz			ICLK = 2 MHz			Unit
			Min	Typ	Max	Min	Typ	Max	
Programming time	4-byte	t _{P4}	—	86	732	—	57	502	μs
Erase time	2-KB	t _{E2K}	—	12.5	355	—	8.8	280	ms
Blank check time	4-byte	t _{BC4}	—	—	46.5	—	—	23.3	μs
	2-KB	t _{BC2K}	—	—	3681	—	—	1841	μs
Erase suspended time		t _{SED}	—	—	22.3	—	—	16.2	μs
Access window information program Start-up area selection and security setting time		t _{AWSSAS}	—	21.2	570	—	15.9	491	ms
OCD/serial programmer ID setting time*1		t _{OSIS}	—	84.7	2280	—	63.5	1964	ms
Flash memory mode transition wait time 1		t _{DIS}	2	—	—	2	—	—	μs
Flash memory mode transition wait time 2		t _{MS}	15	—	—	15	—	—	μs

Note: Does not include the time until each operation of the flash memory is started after instructions are executed by software.

Note: The lower-limit frequency of ICLK is 1 MHz during programming or erasing the flash memory. When using ICLK at below 4 MHz, the frequency can be set to 1 MHz or 2 MHz. A non-integer frequency such as 1.5 MHz cannot be set.

Note: The frequency accuracy of ICLK must be ± 1.0% during programming or erasing the flash memory. Confirm the frequency accuracy of the clock source.

Note 1. Total time of four commands.

2.7.2 Data Flash Memory Characteristics

Table 2.55 Data flash characteristics (1)

Parameter		Symbol	Min	Typ	Max	Unit	Conditions
Reprogramming/erase cycle*1		N _{DPEC}	100000	1000000	—	Times	—
Data hold time	After 10000 times of N _{DPEC}	t _{DDRP}	20*2 *3	—	—	Year	Ta = +105°C
			10	—	—		Ta = +125°C
	After 100000 times of N _{DPEC}		5*2 *3	—	—		Ta = +105°C
			—	1*2 *3	—		Ta = +25°C

Note 1. The reprogram/erase cycle is the number of erasure for each block. When the reprogram/erase cycle is n times (n = 100,000), erasing can be performed n times for each block. For instance, when 1-byte programming is performed 1,024 times for different addresses in 1-KB blocks, and then the entire block is erased, the reprogram/erase cycle is counted as one. However, programming the same address for several times as one erasure is not enabled. (overwriting is prohibited.)

Note 2. Characteristics when using the flash memory programmer and the self-programming library provided by Renesas Electronics.

Note 3. These results are target spec, may changed after reliability testing.

Table 2.56 Data flash characteristics (2) (1 of 2)

High-speed operating mode
Conditions: VCC = 1.8 to 5.5 V

Parameter		Symbol	ICLK = MHz			ICLK = 48 MHz			Unit
			Min	Typ	Max	Min	Typ	Max	
Programming time	1-byte	t _{DP1}	—	45	404	—	34	321	μs
Erase time	1-KB	t _{DE1K}	—	8.8	280	—	6.1	224	ms
Blank check time	1-byte	t _{DBC1}	—	—	15.2	—	—	8.3	μs
	1-KB	t _{DBC1K}	—	—	1832	—	—	466	μs
Suspended time during erasing		t _{DSSED}	—	—	13.2	—	—	10.5	μs

Table 2.56 Data flash characteristics (2) (2 of 2)

High-speed operating mode
Conditions: VCC = 1.8 to 5.5 V

Parameter	Symbol	ICLK = MHz			ICLK = 48 MHz			Unit
		Min	Typ	Max	Min	Typ	Max	
Data flash STOP recovery time	t _{DSTOP}	250	—	—	250	—	—	ns

Note: Does not include the time until each operation of the flash memory is started after instructions are executed by software.

Note: The lower-limit frequency of ICLK is 1 MHz during programming or erasing the flash memory. When using ICLK at below 4 MHz, the frequency can be set to 1 MHz, 2 MHz, or 3 MHz. A non-integer frequency such as 1.5 MHz cannot be set.

Note: The frequency accuracy of ICLK must be $\pm 1.0\%$ during programming or erasing the flash memory. Confirm the frequency accuracy of the clock source.

Table 2.57 Data flash characteristics (3)

Middle-speed operating mode
Conditions: VCC = 1.8 to 5.5 V

Parameter	Symbol	ICLK = MHz			ICLK = MHz* ¹			Unit
		Min	Typ	Max	Min	Typ	Max	
Programming time	1-byte t _{DP1}	—	45	404	—	39	356	μ s
Erase time	1-KB t _{DE1K}	—	8.8	280	—	7.3	248	ms
Blank check time	1-byte t _{DBC1}	—	—	15.2	—	—	11.3	μ s
	1-KB t _{DBC1K}	—	—	1.84	—	—	1.06	ms
Suspended time during erasing	t _{DSED}	—	—	13.2	—	—	11.7	μ s
Data flash STOP recovery time	t _{DSTOP}	250	—	—	250	—	—	ns

Note: Does not include the time until each operation of the flash memory is started after instructions are executed by software.

Note: The lower-limit frequency of ICLK is 1 MHz during programming or erasing the flash memory. When using ICLK at below 4 MHz, the frequency can be set to 1 MHz, 2 MHz, or 3 MHz. A non-integer frequency such as 1.5 MHz cannot be set.

Note: The frequency accuracy of ICLK must be $\pm 1.0\%$ during programming or erasing the flash memory. Confirm the frequency accuracy of the clock source.

Note 1. When $1.8\text{ V} \leq \text{VCC} \leq 5.5\text{ V}$

Table 2.58 Data flash characteristics (4)

Low-speed operating mode
Conditions: VCC = 1.6 to 5.5 V

Parameter	Symbol	ICLK = 1 MHz			ICLK = 2 MHz			Unit
		Min	Typ	Max	Min	Typ	Max	
Programming time	1-byte t _{DP1}	—	86	732	—	57	502	μ s
Erase time	1-KB t _{DE1K}	—	19.7	504	—	12.4	354	ms
Blank check time	1-byte t _{DBC1}	—	—	46.5	—	—	23.3	μ s
	1-KB t _{DBC1K}	—	—	7.3	—	—	3.66	ms
Suspended time during erasing	t _{DSED}	—	—	22.3	—	—	16.2	μ s
Data flash STOP recovery time	t _{DSTOP}	250	—	—	250	—	—	ns

Note: Does not include the time until each operation of the flash memory is started after instructions are executed by software.

Note: The lower-limit frequency of ICLK is 1 MHz during programming or erasing the flash memory. When using ICLK at below 2 MHz, the frequency can be set to 1 MHz or 2 MHz. A non-integer frequency such as 1.5 MHz cannot be set.

Note: The frequency accuracy of ICLK must be $\pm 1.0\%$ during programming or erasing the flash memory. Confirm the frequency accuracy of the clock source.

2.8 Serial Wire Debug (SWD)

Table 2.59 SWD characteristics (1)

Conditions: VCC = 2.4 to 5.5 V

Parameter	Symbol	Min	Typ	Max	Unit	Test conditions
SWCLK clock cycle time	$t_{SWCKcyc}$	80	—	—	ns	Figure 2.52
SWCLK clock high pulse width	t_{SWCKH}	35	—	—	ns	
SWCLK clock low pulse width	t_{SWCKL}	35	—	—	ns	
SWCLK clock rise time	t_{SWCKr}	—	—	5	ns	
SWCLK clock fall time	t_{SWCKf}	—	—	5	ns	
SWDIO setup time	t_{SWDS}	16	—	—	ns	Figure 2.53
SWDIO hold time	t_{SWDH}	16	—	—	ns	
SWDIO data delay time	t_{SWDD}	2	—	70	ns	

Table 2.60 SWD characteristics (2)

Conditions: VCC = 1.6 to 2.4 V

Parameter	Symbol	Min	Typ	Max	Unit	Test conditions
SWCLK clock cycle time	$t_{SWCKcyc}$	250	—	—	ns	Figure 2.52
SWCLK clock high pulse width	t_{SWCKH}	120	—	—	ns	
SWCLK clock low pulse width	t_{SWCKL}	120	—	—	ns	
SWCLK clock rise time	t_{SWCKr}	—	—	5	ns	
SWCLK clock fall time	t_{SWCKf}	—	—	5	ns	
SWDIO setup time	t_{SWDS}	50	—	—	ns	Figure 2.53
SWDIO hold time	t_{SWDH}	50	—	—	ns	
SWDIO data delay time	t_{SWDD}	2	—	170	ns	

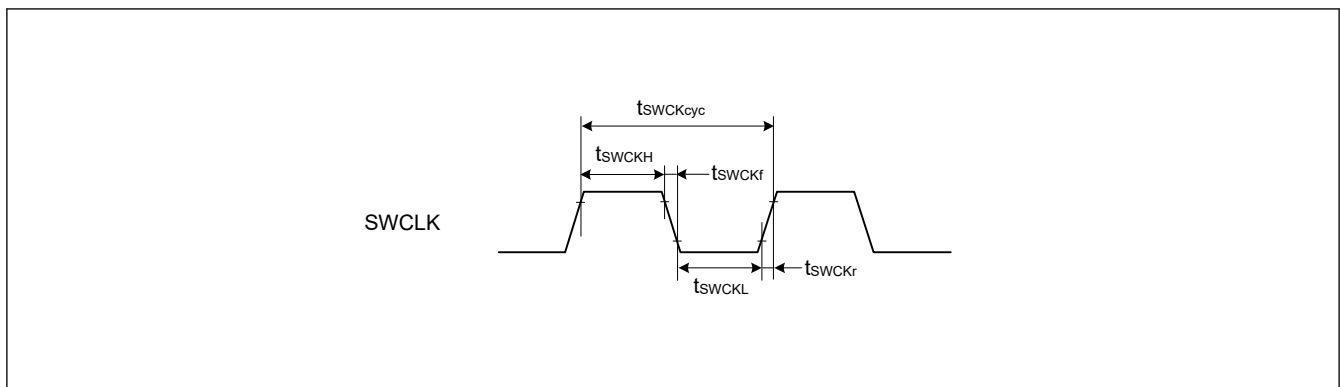

Figure 2.52 SWD SWCLK timing

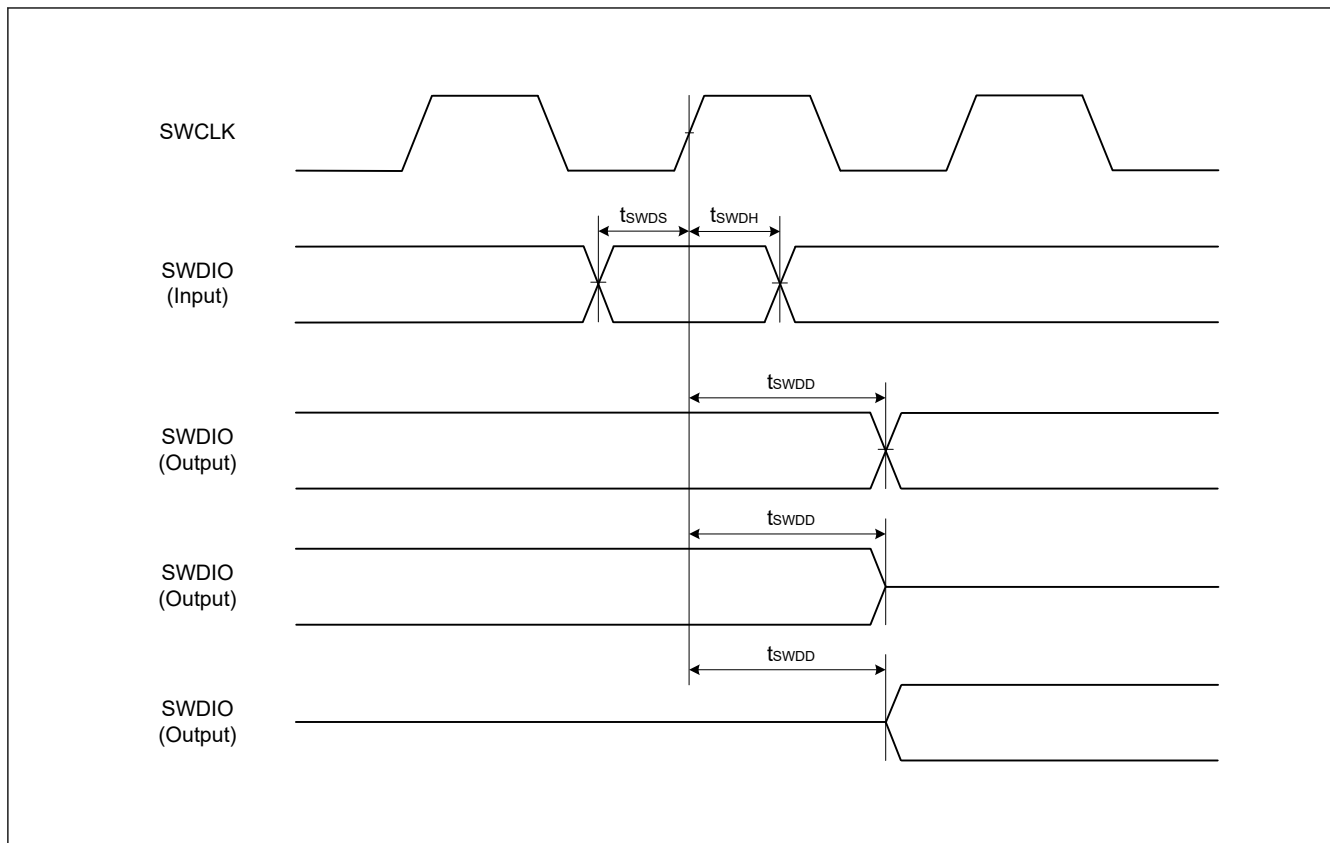

Figure 2.53 SWD input/output timing

Appendix 1. Port States in each Processing Mode

Table 1.1 Port states in each processing mode (1 of 2)

Port name	Reset	Software Standby Mode
P010/AN005	Hi-Z	Keep-O
P011/AN006	Hi-Z	Keep-O
P014/AN009	Hi-Z	Keep-O
P015/AN010/IRQ7_A	Hi-Z	Keep-O ^{*1}
P100/AN022/AGTIO0_A/GTETRGA_A/ GTIOC8B_A/RXD9_E/MISO9_E/SCL9_E/ SCK9_E/MISOA_A/KRM00/IRQ2_A	Hi-Z	[AGTIO0_A output selected] AGTIO0_A output ^{*2} [Other than the above] Keep-O ^{*1}
P101/AN021/AGTEE0/GTETRGA_A/ GTIOC8A_A/TXD9_E/MOSI9_E/SDA9_E/ CTS9_RTS9_G/SS9_G/MOSIA_A/KRM01/ IRQ1_A	Hi-Z	Keep-O ^{*1}
P102/AN020/ADTRG0_A/AGTO0/ GTOWLO_A/GTIOC5B_A/SCK9_C/ TXD9_G/MOSI9_G/SDA9_G/RSPCKA_A/ KRM02/IRQ4_C	Hi-Z	[AGTO0 selected] AGTO0 output ^{*2} [Other than the above] Keep-O ^{*1}
P103/AN019/AGTOB0_B/GTOWUP_A/ GTIOC5A_A/CTS9_RTS9_E/SS9_E/ RXD9_I/MISO9_I/SCL9_I/SSLA0_A/KRM03/ IRQ6_C	Hi-Z	Keep-O ^{*1}
P108/SWDIO/AGTOA1_B/GTOULO_C/ GTIOC7B_C/TXD9_H/MOSI9_H/SDA9_H/ CTS9_RTS9_B/SS9_B/MOSIA_C/IRA5_C	Pull-up	Keep-O
P109/AGTO1_A/GTOVUP_C/GTIOC4A_A/ SCK9_F/TXD9_B/MOSI9_B/SDA9_B/ MISOA_C/KRM01_B/IRQ7_C/CLKOUT_B	Hi-Z	[CLKOUT selected] CLKOUT output [Other than the above] Keep-O
P110/AGTOA0_A/GTOVLO_A/GTIOC4B_A/ CTS9_RTS9_H/SS9_H/RXD9_B/MISO9_B/ SCL9_B/SSLA0_C/KRM00_B/IRQ3_A	Hi-Z	Keep-O ^{*1}
P111/AGTOA0/GTIOC6A_A/RXD9_G/ MISO9_G/SCL9_G/SCK9_B/KRM03_B/ IRQ4_A	Hi-Z	[AGTOA0 selected] AGTOA0 output ^{*2} [Other than the above] Keep-O ^{*1}
P112/AGTOB0/GTIOC6B_A/TXD9_J/ MOSI9_J/SDA9_J/CTS9_RTS9_I/SS9_I/ KRM02_B/IRQ1_C	Hi-Z	[AGTOB0 selected] AGTOB0 output ^{*2} [Other than the above] Keep-O
P200/NMI	Hi-Z	Hi-Z
P201/MD	Pull-up	Keep-O
P205/AGTO1/TXD9_I/MOSI9_I/SDA9_I/ CTS9_RTS9_A/SS9_A/KRM01_A/IRQ1/ CLKOUT_A	Hi-Z	[AGTO1 selected] AGTO1 output ^{*2} [CLKOUT selected] CLKOUT output [Other than the above] Keep-O ^{*1}
P300/SWCLK/AGTOB1_A/GTOUUP_C/ GTIOC7A_C/RXD9_H/MOSI9_H/SCL9_H/ SCK9_G/RSPCKA_C/IRQ0_C	Pull-up	Keep-O
P400/CACREF_C/AGTIO1_C/GTIOC9A_A/ SCK9_D/TXD9_F/MOSI9_F/SDA9_F/ SCL0_A/KRM02_A/IRQ0_A	Hi-Z	[AGTIO1_C output selected] AGTIO1_C output ^{*2} [Other than the above] Keep-O ^{*1}

Table 1.1 Port states in each processing mode (2 of 2)

Port name	Reset	Software Standby Mode
P401/AGTEE1_A/GTETRGA_B/ GTIOC9B_A/CTS9_RTS9_F/SS9_F/ RXD9_F/MISO9_F/SCL9_F/SDA0_A/IRQ5/ KRM03_A	Hi-Z	Keep-O ^{*1}
P914/AGTOA1_A/GTETRGA_F/RXD9_J/ MISO9_J/SCL9_J/SCK9_H/KRM00_A/ IRQ2_C	Hi-Z	[AGTOA1 selected] AGTOA1 output ^{*2} [Other than the above] Keep-O ^{*1}

Note: Hi-Z: High-impedance

Keep-O: Output pins retain their previous values. Input pins become high-impedance.

Note 1. Input is enabled if the pin is specified as the software standby canceling source while it is used as an external interrupt pin.

Note 2. AGTIO output is enabled while LOCO is selected as a count source.

Appendix 2. Package Dimensions

Information on the latest version of the package dimensions or mountings is displayed in packages on the Renesas Electronics Corporation website.

JEITA Package Code	RENESAS Code	MASS (Typ.) [g]
P-HWQFN24-4 × 4-0.50	PWQNO024KG-A	0.04

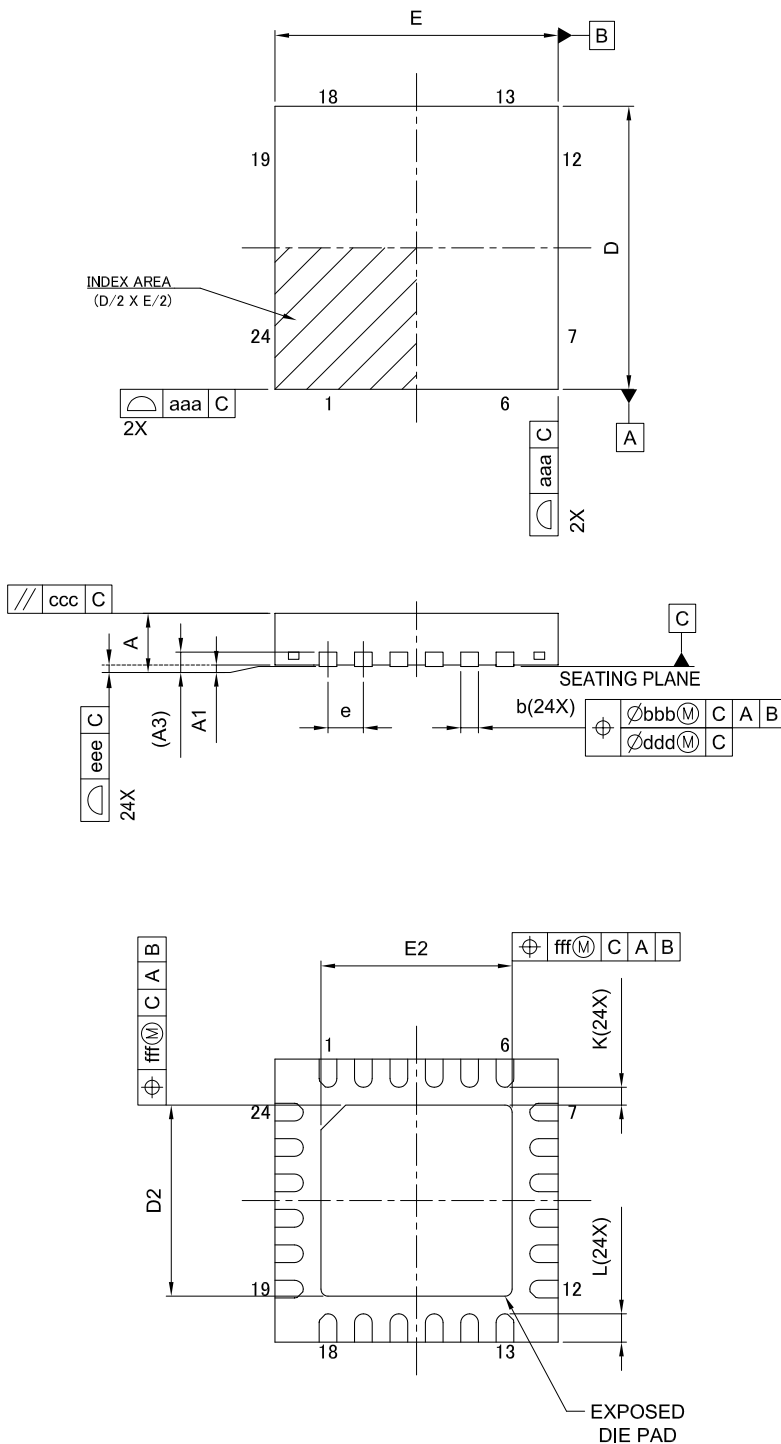

Reference Symbol	Dimension in Millimeters		
	Min.	Nom.	Max.
A	—	—	0.80
A ₁	0.00	0.02	0.05
A ₃	0.203 REF.		
b	0.18	0.25	0.30
D	4.00 BSC		
E	4.00 BSC		
e	0.50 BSC		
L	0.35	0.40	0.45
K	0.20	—	—
D ₂	2.65	2.70	2.75
E ₂	2.65	2.70	2.75
aaa	0.15		
bbb	0.10		
ccc	0.10		
ddd	0.05		
eee	0.08		
fff	0.10		

Figure 2.1 HWQFN 24-pin

JEITA Package Code	RENESAS Code	MASS (Typ.) [g]
P-HWQFN20-4 × 4-0.50	PWQN0020KC-A	0.04

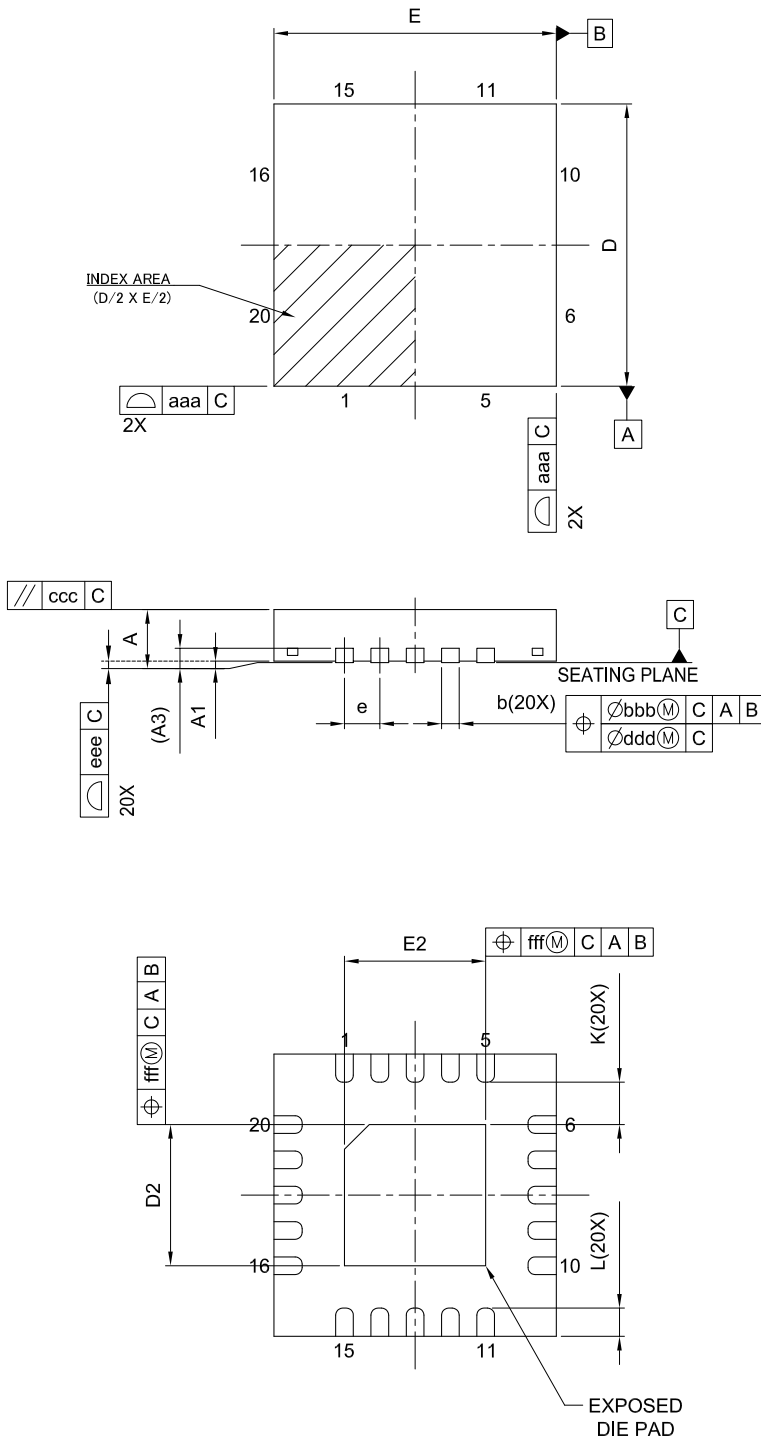

Reference Symbol	Dimension in Millimeters		
	Min.	Nom.	Max.
A	—	—	0.80
A ₁	0.00	0.02	0.05
A ₃	0.203 REF.		
b	0.20	0.25	0.30
D	4.00 BSC		
E	4.00 BSC		
e	0.50 BSC		
L	0.30	0.40	0.50
K	0.20	—	—
D ₂	1.95	2.00	2.05
E ₂	1.95	2.00	2.05
aaa	0.15		
bbb	0.10		
ccc	0.10		
ddd	0.05		
eee	0.08		
fff	0.10		

Figure 2.2 HWQFN 20-pin

JEITA Package code	RENESAS code	MASS(TYP.)[g]
S-UFBGA16-1.84x1.87-0.40	SUBG0016LB-A	0.01

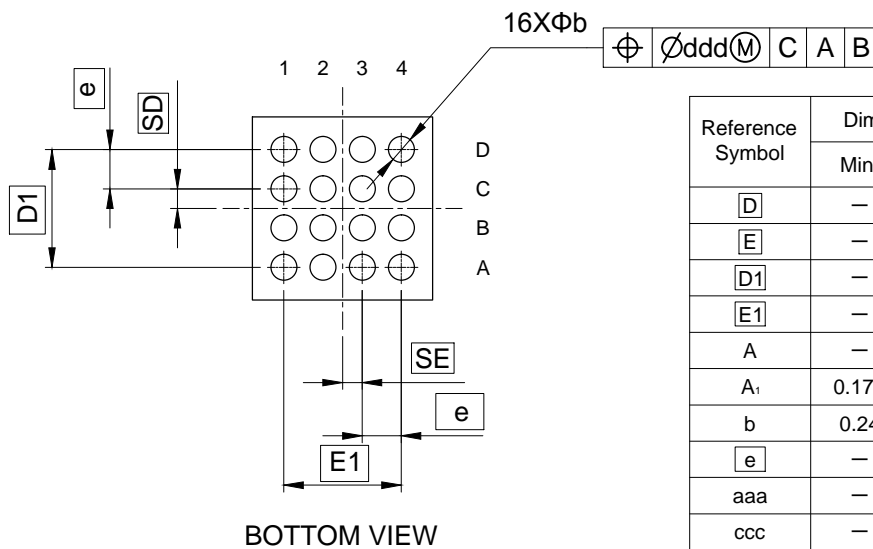
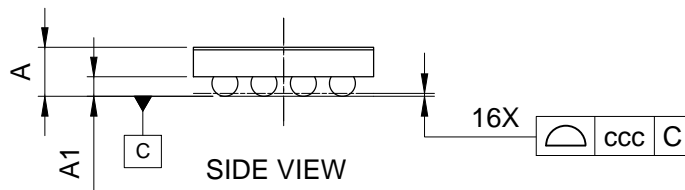
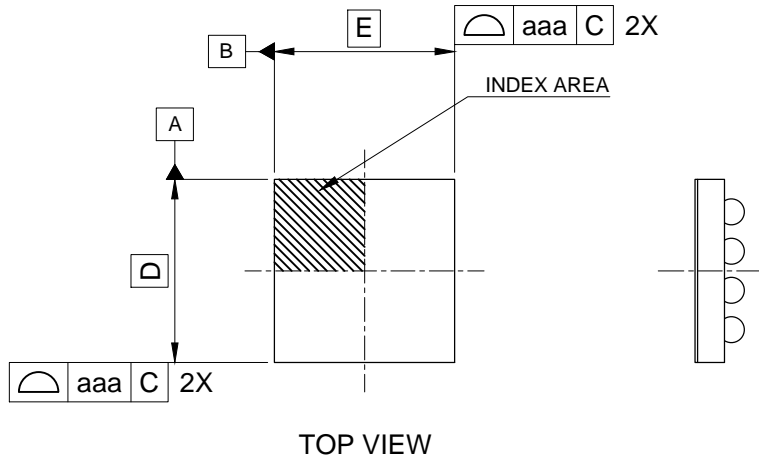

Reference Symbol	Dimension in Millimeters		
	Min.	Nom.	Max.
D	—	1.87	—
E	—	1.84	—
D1	—	1.20	—
E1	—	1.20	—
A	—	—	0.55
A ₁	0.175	0.20	0.225
b	0.24	0.265	0.29
e	—	0.40	—
aaa	—	—	0.05
ccc	—	—	0.05
ddd	—	—	0.05
SD	—	0.200	—
SE	—	0.200	—

Figure 2.3 WLCSP 16-pin

Appendix 3. I/O Registers

This appendix describes I/O register addresses, access cycles, and reset values by function.

3.1 Peripheral Base Addresses

This section provides the base addresses for peripherals described in this manual.

Table 3.1 shows the name, description, and the base address of each peripheral.

Table 3.1 Peripheral base address (1 of 2)

Name	Description	Base address
MPU	Memory Protection Unit	0x4000_0000
SRAM	SRAM Control	0x4000_2000
BUS	BUS Control	0x4000_3000
DTC	Data Transfer Controller	0x4000_5400
ICU	Interrupt Controller	0x4000_6000
CPU_DBG	Debug Function	0x4001_B000
SYSC	System Control	0x4001_E000
PORT0	Port 0 Control Registers	0x4004_0000
PORT1	Port 1 Control Registers	0x4004_0020
PORT2	Port 2 Control Registers	0x4004_0040
PORT3	Port 3 Control Registers	0x4004_0060
PORT4	Port 4 Control Registers	0x4004_0080
PORT9	Port 9 Control Registers	0x4004_0120
PFS	Pmn Pin Function Control Register	0x4004_0800
ELC	Event Link Controller	0x4004_1000
POEG	Port Output Enable Module for GPT	0x4004_2000
WDT	Watchdog Timer	0x4004_4200
IWDT	Independent Watchdog Timer	0x4004_4400
CAC	Clock Frequency Accuracy Measurement Circuit	0x4004_4600
MSTP	Module Stop Control B, C, D	0x4004_7000
I3C	I3C Bus Interface	0x4008_3000
DOC	Data Operation Circuit	0x4005_4100
ADC12	12-bit A/D Converter	0x4005_C000
SCI9	Serial Communication Interface 9	0x4007_0120
SPI0	Serial Peripheral Interface 0	0x4007_2000
CRC	CRC Calculator	0x4007_4000
GPT164	General PWM Timer 4 (16-bit)	0x4007_8400
GPT165	General PWM Timer 5 (16-bit)	0x4007_8500
GPT166	General PWM Timer 6 (16-bit)	0x4007_8600
GPT167	General PWM Timer 7 (16-bit)	0x4007_8700
GPT168	General PWM Timer 8 (16-bit)	0x4007_8800
GPT169	General PWM Timer 9 (16-bit)	0x4007_8900
GPT_OPS	Output Phase Switching Controller	0x4007_8FF0
KINT	Key Interrupt Function	0x4008_0000
AGTW0	Low Power Asynchronous General Purpose Timer W0	0x4008_4000

Table 3.1 Peripheral base address (2 of 2)

Name	Description	Base address
AGTW1	Low Power Asynchronous General Purpose Timer W1	0x4008_4100
FLCN	Flash I/O Registers	0x407E_C000

Note: Name = Peripheral name
Description = Peripheral functionality
Base address = Lowest reserved address or address used by the peripheral

3.2 Access Cycles

This section provides access cycle information for the I/O registers described in this manual.

The following information applies to [Table 3.2](#):

- Registers are grouped by associated module.
- The number of access cycles indicates the number of cycles based on the specified reference clock.
- In the internal I/O area, reserved addresses that are not allocated to registers must not be accessed, otherwise operations cannot be guaranteed.
- The number of I/O access cycles depends on bus cycles of the internal peripheral bus, divided clock synchronization cycles, and wait cycles of each module. Divided clock synchronization cycles differ depending on the frequency ratio between ICLK and PCLK.
- When the frequency of ICLK is equal to that of PCLK, the number of divided clock synchronization cycles is always constant.
- When the frequency of ICLK is greater than that of PCLK, at least 1 PCLK cycle is added to the number of divided clock synchronization cycles.

Note: This applies to the number of cycles when access from the CPU does not conflict with the instruction fetching to the external memory or bus access from other bus master such as DTC.

[Table 3.2](#) shows the register access cycles for non-GPT modules.

Table 3.2 Access cycles for non-GPT modules (1 of 2)

Peripherals	Address		Number of access cycles				Cycle unit	Related function
			ICLK = PCLK		ICLK > PCLK*1			
			From	To	Read	Write		
MPU, SRAM, BUS, DTC, ICU, CPU_DBG	0x4000_2000	0x4001_BFFF	3				ICLK	Memory Protection Unit, SRAM, Buses, Data Transfer Controller, Interrupt Controller, CPU, Flash Memory
SYSC	0x4001_E000	0x4001_E6FF	4				ICLK	Low Power Modes, Resets, Low Voltage Detection, Clock Generation Circuit, Register Write Protection
PORTn, PFS, ELC, POEG, WDT, IWDT, CAC, MSTP	0x4004_0000	0x4004_7FFF	3		2 to 3		PCLKB	I/O Ports, Event Link Controller, Port Output Enable for GPT, Watchdog Timer, Independent Watchdog Timer, Clock Frequency Accuracy Measurement Circuit, Module Stop Control
DOC, ADC12	0x4005_4100	0x4005_EFFF	3		2 to 3		PCLKB	Data Operation Circuit, 12-bit A/D Converter
SCIn (n = 9)	0x4007_0000	0x4007_0EFF	5		2 to 3		PCLKB	Serial Communications Interface
SPIIn (n = 0)*2	0x4007_2000	0x4007_2FFF	5		2 to 3		PCLKB	Serial Peripheral Interface
CRC	0x4007_4000	0x4007_4FFF	3		2 to 3		PCLKB	CRC Calculator

Table 3.2 Access cycles for non-GPT modules (2 of 2)

Peripherals	Address		Number of access cycles				Cycle unit	Related function
			ICLK = PCLK		ICLK > PCLK*1			
	From	To	Read	Write	Read	Write		
GPT16n (n = 4 to 9), GPT_OPS	0x4007_8000	0x4007_BFFF	See Table 3.3.				PCLKB	General PWM Timer
KINT	0x4008_0000	0x4008_2FFF	3		2 to 3		PCLKB	Key interrupt Function, Capacitive Sensing Unit 2
AGTWn	0x4008_4000	0x4008_4FFF	3		2 to 3		PCLKB	Low Power Asynchronous General Purpose Timer
FLCN	0x407E_C000	0x407E_FFFF	7		7		ICLK	Data Flash, Temperature Sensor, Capacitive Sensing Unit 2, Flash Control
I3C	0x4008_3000	0x4008_33D0	3		2 to 3		PCLKB	I3C Bus Interface

Note 1. If the number of PCLK cycles is non-integer (for example 1.5), the minimum value is without the decimal point, and the maximum value is rounded up to the decimal point. For example, 1.5 to 2.5 is 1 to 3.

Note 2. When accessing the 32-bit register (SPDR), access is 2 cycles more than the value in Table 3.2. When accessing an 8-bit or 16-bit register (SPDR_HA), the access cycles are as shown in Table 3.2.

Table 3.3 shows register access cycles for GPT modules.

Table 3.3 Access cycles for GPT modules

Frequency ratio between ICLK and PCLK	Number of access cycles		Cycle unit
	Read	Write	
ICLK > PCLKD = PCLKB	5 to 6	3 to 4	PCLKB
ICLK > PCLKD > PCLKB	3 to 4	2 to 3	PCLKB
PCLKD = ICLK = PCLKB	6	4	PCLKB
PCLKD = ICLK > PCLKB	2 to 3	1 to 2	PCLKB
PCLKD > ICLK = PCLKB	4	3	PCLKB
PCLKD > ICLK > PCLKB	2 to 3	1 to 2	PCLKB

3.3 Register Descriptions

This section provides information associated with registers described in this manual.

Table 3.4 shows a list of registers including address offsets, address sizes, access rights, and reset values.

Table 3.4 Register description (1 of 11)

Peripheral name	Dim	Dim inc.	Dim index	Register name	Description	Address offset	Size	R/W	Reset value	Reset mask
MPU	-	-	-	MMPUCTLA	Bus Master MPU Control Register	0x000	16	R/W	0x0000	0xFFFF
MPU	-	-	-	MMPUPTA	Group A Protection of Register	0x102	16	R/W	0x0000	0xFFFF
MPU	4	0x010	0-3	MMPUACA%s	Group A Region %s access control register	0x200	16	R/W	0x0000	0xFFFF
MPU	4	0x010	0-3	MMPUSA%s	Group A Region %s Start Address Register	0x204	32	R/W	0x00000000	0x00000003
MPU	4	0x010	0-3	MMPUEA%s	Group A Region %s End Address Register	0x208	32	R/W	0x00000003	0x00000003
MPU	-	-	-	SMPUCTL	Slave MPU Control Register	0xC00	16	R/W	0x0000	0xFFFF
MPU	-	-	-	SMPUMBIU	Access Control Register for Memory Bus 1	0xC10	16	R/W	0x0000	0xFFFF
MPU	-	-	-	SMPUFBIU	Access Control Register for Internal Peripheral Bus 9	0xC14	16	R/W	0x0000	0xFFFF
MPU	-	-	-	SMPUSRAM0	Access Control Register for Memory Bus 4	0xC18	16	R/W	0x0000	0xFFFF
MPU	-	-	-	SMPUP0BIU	Access Control Register for Internal Peripheral Bus 1	0xC20	16	R/W	0x0000	0xFFFF

Table 3.4 Register description (2 of 11)

Peripheral name	Dim	Dim inc.	Dim index	Register name	Description	Address offset	Size	R/W	Reset value	Reset mask
MPU	-	-	-	SMPUP2BIU	Access Control Register for Internal Peripheral Bus 3	0xC24	16	R/W	0x0000	0xFFFF
MPU	-	-	-	SMPUP6BIU	Access Control Register for Internal Peripheral Bus 7	0xC28	16	R/W	0x0000	0xFFFF
MPU	-	-	-	MSPMPUOAD	Stack Pointer Monitor Operation After Detection Register	0xD00	16	R/W	0x0000	0xFFFF
MPU	-	-	-	MSPMPUCTL	Stack Pointer Monitor Access Control Register	0xD04	16	R/W	0x0000	0xFEFF
MPU	-	-	-	MSPMPUPT	Stack Pointer Monitor Protection Register	0xD06	16	R/W	0x0000	0xFFFF
MPU	-	-	-	MSPMPUSA	Main Stack Pointer (MSP) Monitor Start Address Register	0xD08	32	R/W	0x00000000	0x00000000
MPU	-	-	-	MSPMPUEA	Main Stack Pointer (MSP) Monitor End Address Register	0xD0C	32	R/W	0x00000000	0x00000000
MPU	-	-	-	PSPMPUOAD	Stack Pointer Monitor Operation After Detection Register	0xD10	16	R/W	0x0000	0xFFFF
MPU	-	-	-	PSPMPUCTL	Stack Pointer Monitor Access Control Register	0xD14	16	R/W	0x0000	0xFEFF
MPU	-	-	-	PSPMPUPT	Stack Pointer Monitor Protection Register	0xD16	16	R/W	0x0000	0xFFFF
MPU	-	-	-	PSPMPUSA	Process Stack Pointer (PSP) Monitor Start Address Register	0xD18	32	R/W	0x00000000	0x00000000
MPU	-	-	-	PSPMPUEA	Process Stack Pointer (PSP) Monitor End Address Register	0xD1C	32	R/W	0x00000000	0x00000000
SRAM	-	-	-	PARIOAD	SRAM Parity Error Operation After Detection Register	0x00	8	R/W	0x00	0xFF
SRAM	-	-	-	SRAMPCR	SRAM Protection Register	0x04	8	R/W	0x00	0xFF
BUS	-	-	-	BUSMCNTSYS	Master Bus Control Register SYS	0x1008	16	R/W	0x0000	0xFFFF
BUS	-	-	-	BUSMCNTDMA	Master Bus Control Register DMA	0x100C	16	R/W	0x0000	0xFFFF
BUS	-	-	-	BUS3ERRADD	Bus Error Address Register 3	0x1820	32	R	0x00000000	0x00000000
BUS	-	-	-	BUS3ERRSTAT	BUS Error Status Register 3	0x1824	8	R	0x00	0xFE
BUS	-	-	-	BUS4ERRADD	Bus Error Address Register 4	0x1830	32	R	0x00000000	0x00000000
BUS	-	-	-	BUS4ERRSTAT	BUS Error Status Register 4	0x1834	8	R	0x00	0xFE
DTC	-	-	-	DTCCR	DTC Control Register	0x00	8	R/W	0x08	0xFF
DTC	-	-	-	DTCVBR	DTC Vector Base Register	0x04	32	R/W	0x00000000	0xFFFFFFFF
DTC	-	-	-	DTCST	DTC Module Start Register	0x0C	8	R/W	0x00	0xFF
DTC	-	-	-	DTCSTS	DTC Status Register	0x0E	16	R	0x0000	0xFFFF
ICU	8	0x1	0-7	IRQCR%s	IRQ Control Register	0x000	8	R/W	0x00	0xFF
ICU	-	-	-	NMICR	NMI Pin Interrupt Control Register	0x100	8	R/W	0x00	0xFF
ICU	-	-	-	NMIER	Non-Maskable Interrupt Enable Register	0x120	16	R/W	0x0000	0xFFFF
ICU	-	-	-	NMICLR	Non-Maskable Interrupt Status Clear Register	0x130	16	R/W	0x0000	0xFFFF
ICU	-	-	-	NMISR	Non-Maskable Interrupt Status Register	0x140	16	R	0x0000	0xFFFF
ICU	-	-	-	WUPEN	Wake Up Interrupt Enable Register	0x1A0	32	R/W	0x00000000	0xFFFFFFFF
ICU	-	-	-	IELEN	ICU event Enable Register	0x1C0	8	R/W	0x00	0xFF
ICU	-	-	-	SELSR0	SYS Event Link Setting Register	0x200	16	R/W	0x0000	0xFFFF
ICU	32	0x4	0-31	IELSR%s	ICU Event Link Setting Register %s	0x300	32	R/W	0x00000000	0xFFFFFFFF
CPU_DBG	-	-	-	DBGSTR	Debug Status Register	0x00	32	R	0x00000000	0xFFFFFFFF
CPU_DBG	-	-	-	DBGSTOPCR	Debug Stop Control Register	0x10	32	R/W	0x00000003	0xFFFFFFFF
SYSC	-	-	-	SBYCR	Standby Control Register	0x00C	16	R/W	0x0000	0xFFFF
SYSC	-	-	-	MSTPCRA	Module Stop Control Register A	0x01C	32	R/W	0xFFBFFFFFFF	0xFFFFFFFF
SYSC	-	-	-	SCKDIVCR	System Clock Division Control Register	0x020	32	R/W	0x04000404	0xFFFFFFFF
SYSC	-	-	-	SCKSCR	System Clock Source Control Register	0x026	8	R/W	0x01	0xFF

Table 3.4 Register description (3 of 11)

Peripheral name	Dim	Dim inc.	Dim index	Register name	Description	Address offset	Size	R/W	Reset value	Reset mask
SYSC	-	-	-	MEMWAIT	Memory Wait Cycle Control Register for Code Flash	0x031	8	R/W	0x00	0xFF
SYSC	-	-	-	HOCOCCR	High-Speed On-Chip Oscillator Control Register	0x036	8	R/W	0x00	0xFE
SYSC	-	-	-	MOCOCCR	Middle-Speed On-Chip Oscillator Control Register	0x038	8	R/W	0x00	0xFF
SYSC	-	-	-	OOSCF	Oscillation Stabilization Flag Register	0x03C	8	R	0x00	0xFE
SYSC	-	-	-	CKOCCR	Clock Out Control Register	0x03E	8	R/W	0x00	0xFF
SYSC	-	-	-	LPOPT	Lower Power Operation Control Register	0x04C	8	R/W	0x00	0xFF
SYSC	-	-	-	MOCOUTCR	MOCO User Trimming Control Register	0x061	8	R/W	0x00	0xFF
SYSC	-	-	-	HOCOUTCR	HOCO User Trimming Control Register	0x062	8	R/W	0x00	0xFF
SYSC	-	-	-	SNZCR	Snooze Control Register	0x092	8	R/W	0x00	0xFF
SYSC	-	-	-	SNZEDCR0	Snooze End Control Register 0	0x094	8	R/W	0x00	0xFF
SYSC	-	-	-	SNZREQCR0	Snooze Request Control Register 0	0x098	32	R/W	0x00000000	0xFFFFFFFF
SYSC	-	-	-	PSMCR	Power Save Memory Control Register	0x09F	8	R/W	0x00	0xFF
SYSC	-	-	-	OPCCR	Operating Power Control Register	0x0A0	8	R/W	0x01	0xFF
SYSC	-	-	-	HOCOWTCR	High-Speed On-Chip Oscillator Wait Control Register	0x0A5	8	R/W	0x05	0xFF
SYSC	-	-	-	SOPCCR	Sub Operating Power Control Register	0x0AA	8	R/W	0x00	0xFF
SYSC	-	-	-	RSTSR1	Reset Status Register 1	0x0C0	16	R/W	0x0000	0xE2F8
SYSC	-	-	-	LVD1CR1	Voltage Monitor 1 Circuit Control Register	0x0E0	8	R/W	0x01	0xFF
SYSC	-	-	-	LVD1SR	Voltage Monitor 1 Circuit Status Register	0x0E1	8	R/W	0x02	0xFF
SYSC	-	-	-	LVD2CR1	Voltage Monitor 2 Circuit Control Register 1	0x0E2	8	R/W	0x01	0xFF
SYSC	-	-	-	LVD2SR	Voltage Monitor 2 Circuit Status Register	0x0E3	8	R/W	0x02	0xFF
SYSC	-	-	-	PRCR	Protect Register	0x3FE	16	R/W	0x0000	0xFFFF
SYSC	-	-	-	SYOCDCR	System Control OCD Control Register	0x040E	8	R/W	0x00	0xFF
SYSC	-	-	-	RSTSR0	Reset Status Register 0	0x410	8	R/W	0x00	0xF0
SYSC	-	-	-	RSTSR2	Reset Status Register 2	0x411	8	R/W	0x00	0xFE
SYSC	-	-	-	LVCMPCCR	Voltage Monitor Circuit Control Register	0x417	8	R/W	0x00	0xFF
SYSC	-	-	-	LVDLVLRL	Voltage Detection Level Select Register	0x418	8	R/W	0x07	0xFF
SYSC	-	-	-	LVD1CR0	Voltage Monitor 1 Circuit Control Register 0	0x41A	8	R/W	0x80	0xF7
SYSC	-	-	-	LVD2CR0	Voltage Monitor 2 Circuit Control Register 0	0x41B	8	R/W	0x80	0xF7
SYSC	-	-	-	LOCOCCR	Low-Speed On-Chip Oscillator Control Register	0x490	8	R/W	0x00	0xFF
SYSC	-	-	-	LOCOUTCR	LOCO User Trimming Control Register	0x492	8	R/W	0x00	0xFF
PORT0,3-4,9	-	-	-	PCNTR1	Port Control Register 1	0x000	32	R/W	0x00000000	0xFFFFFFFF
PORT0,3-4,9	-	-	-	PODR	Port Control Register 1	0x000	16	R/W	0x0000	0xFFFF
PORT0,3-4,9	-	-	-	PDR	Port Control Register 1	0x002	16	R/W	0x0000	0xFFFF
PORT0,3-4,9	-	-	-	PCNTR2	Port Control Register 2	0x004	32	R	0x00000000	0xFFFF0000
PORT0,3-4,9	-	-	-	PIDR	Port Control Register 2	0x006	16	R	0x0000	0x0000
PORT0,3-4,9	-	-	-	PCNTR3	Port Control Register 3	0x008	32	W	0x00000000	0xFFFFFFFF
PORT0,3-4,9	-	-	-	PORR	Port Control Register 3	0x008	16	W	0x0000	0xFFFF

Table 3.4 Register description (4 of 11)

Peripheral name	Dim	Dim inc.	Dim index	Register name	Description	Address offset	Size	R/W	Reset value	Reset mask
PORT0,3-4,9	-	-	-	POSR	Port Control Register 3	0x00A	16	W	0x0000	0xFFFF
PORT1-2	-	-	-	PCNTR1	Port Control Register 1	0x000	32	R/W	0x00000000	0xFFFFFFFF
PORT1-2	-	-	-	PODR	Port Control Register 1	0x000	16	R/W	0x0000	0xFFFF
PORT1-2	-	-	-	PDR	Port Control Register 1	0x002	16	R/W	0x0000	0xFFFF
PORT1-2	-	-	-	PCNTR2	Port Control Register 2	0x004	32	R	0x00000000	0xFFFF0000
PORT1-2	-	-	-	EIDR	Port Control Register 2	0x004	16	R	0x0000	0xFFFF
PORT1-2	-	-	-	PIDR	Port Control Register 2	0x006	16	R	0x0000	0x0000
PORT1-2	-	-	-	PCNTR3	Port Control Register 3	0x008	32	W	0x00000000	0xFFFFFFFF
PORT1-2	-	-	-	PORR	Port Control Register 3	0x008	16	W	0x0000	0xFFFF
PORT1-2	-	-	-	POSR	Port Control Register 3	0x00A	16	W	0x0000	0xFFFF
PORT1-2	-	-	-	PCNTR4	Port Control Register 4	0x00C	32	R/W	0x00000000	0xFFFFFFFF
PORT1-2	-	-	-	EORR	Port Control Register 4	0x00C	16	R/W	0x0000	0xFFFF
PORT1-2	-	-	-	EOSR	Port Control Register 4	0x00E	16	R/W	0x0000	0xFFFF
PFS	4	0x4	10, 11, 14, 15	P0%PFS	Port 0% Pin Function Select Register	0x028	32	R/W	0x00000000	0xFFFFFFFFD
PFS	4	0x4	10, 11, 14, 15	P0%PFS_HA	Port 0% Pin Function Select Register	0x02A	16	R/W	0x0000	0xFFFD
PFS	4	0x4	10, 11, 14, 15	P0%PFS_BY	Port 0% Pin Function Select Register	0x02B	8	R/W	0x00	0xFD
PFS	4	0x4	0-3	P10%PFS	Port 10% Pin Function Select Register	0x040	32	R/W	0x00000000	0xFFFFFFFFD
PFS	4	0x4	0-3	P10%PFS_HA	Port 10% Pin Function Select Register	0x042	16	R/W	0x0000	0xFFFD
PFS	4	0x4	0-3	P10%PFS_BY	Port 10% Pin Function Select Register	0x043	8	R/W	0x00	0xFD
PFS	-	-	-	P108PFS	Port 108 Pin Function Select Register	0x060	32	R/W	0x00010010	0xFFFFFFFFD
PFS	-	-	-	P108PFS_HA	Port 108 Pin Function Select Register	0x062	16	R/W	0x0010	0xFFFD
PFS	-	-	-	P108PFS_BY	Port 108 Pin Function Select Register	0x063	8	R/W	0x10	0xFD
PFS	-	-	-	P109PFS	Port 109 Pin Function Select Register	0x064	32	R/W	0x00000000	0xFFFFFFFFD
PFS	-	-	-	P109PFS_HA	Port 109 Pin Function Select Register	0x066	16	R/W	0x0000	0xFFFD
PFS	-	-	-	P109PFS_BY	Port 109 Pin Function Select Register	0x067	8	R/W	0x00	0xFD
PFS	3	0x4	10-12	P1%PFS	Port 1% Pin Function Select Register	0x068	32	R/W	0x00000000	0xFFFFFFFFD
PFS	3	0x4	10-12	P1%PFS_HA	Port 1% Pin Function Select Register	0x06A	16	R/W	0x0000	0xFFFD
PFS	3	0x4	10-12	P1%PFS_BY	Port 1% Pin Function Select Register	0x06B	8	R/W	0x00	0xFD
PFS	-	-	-	P200PFS	Port 200 Pin Function Select Register	0x080	32	R/W	0x00000000	0xFFFFFFFFD
PFS	-	-	-	P200PFS_HA	Port 200 Pin Function Select Register	0x082	16	R/W	0x0000	0xFFFD
PFS	-	-	-	P200PFS_BY	Port 200 Pin Function Select Register	0x083	8	R/W	0x00	0xFD
PFS	-	-	-	P201PFS	Port 201 Pin Function Select Register	0x084	32	R/W	0x00000010	0xFFFFFFFFD
PFS	-	-	-	P201PFS_HA	Port 201 Pin Function Select Register	0x086	16	R/W	0x0010	0xFFFD
PFS	-	-	-	P201PFS_BY	Port 201 Pin Function Select Register	0x087	8	R/W	0x10	0xFD
PFS	1	0x4	5	P20%PFS	Port 20% Pin Function Select Register	0x094	32	R/W	0x00000000	0xFFFFFFFFD
PFS	1	0x4	5	P20%PFS_HA	Port 20% Pin Function Select Register	0x096	16	R/W	0x0000	0xFFFD
PFS	1	0x4	5	P20%PFS_BY	Port 20% Pin Function Select Register	0x097	8	R/W	0x00	0xFD
PFS	-	-	-	P300PFS	Port 300 Pin Function Select Register	0x0C0	32	R/W	0x00010000	0xFFFFFFFFD
PFS	-	-	-	P300PFS_HA	Port 300 Pin Function Select Register	0x0C2	16	R/W	0x0000	0xFFFD
PFS	-	-	-	P300PFS_BY	Port 300 Pin Function Select Register	0x0C3	8	R/W	0x00	0xFD
PFS	2	0x4	0-1	P40%PFS	Port 40% Pin Function Select Register	0x100	32	R/W	0x00000000	0xFFFFFFFFD
PFS	2	0x4	0-1	P40%PFS_HA	Port 40% Pin Function Select Register	0x102	16	R/W	0x0000	0xFFFD
PFS	2	0x4	0-1	P40%PFS_BY	Port 40% Pin Function Select Register	0x103	8	R/W	0x00	0xFD

Table 3.4 Register description (5 of 11)

Peripheral name	Dim	Dim inc.	Dim index	Register name	Description	Address offset	Size	R/W	Reset value	Reset mask
PFS	-	-	-	P914PFS	Port 914 Pin Function Select Register	0xA78	32	R/W	0x00000000	0xFFFFFFFF
PFS	-	-	-	P914PFS_HA	Port 914 Pin Function Select Register	0xA7A	16	R/W	0x0000	0xFFFF
PFS	-	-	-	P914PFS_BY	Port 914 Pin Function Select Register	0xA7B	8	R/W	0x00	0xFD
PFS	-	-	-	PWPR	Write-Protect Register	0x503	8	R/W	0x80	0xFF
PFS	-	-	-	PRWCNTR	Port Read Wait Control Register	0x50F	8	R/W	0x01	0xFF
ELC	-	-	-	ELCR	Event Link Controller Register	0x00	8	R/W	0x00	0xFF
ELC	2	0x02	0-1	ELSEGR%s	Event Link Software Event Generation Register %s	0x02	8	R/W	0x80	0xFF
ELC	4	0x04	0-3	ELSR%s	Event Link Setting Register %s	0x10	16	R/W	0x0000	0xFFFF
ELC	2	0x04	8-9	ELSR%s	Event Link Setting Register %s	0x30	16	R/W	0x0000	0xFFFF
ELC	2	0x04	14-15	ELSR%s	Event Link Setting Register %s	0x48	16	R/W	0x0000	0xFFFF
ELC	-	-	-	ELSR18	Event Link Setting Register 18	0x58	16	R/W	0x0000	0xFFFF
POEG	-	-	-	POEGGA	POEG Group A Setting Register	0x000	32	R/W	0x00000000	0xFFFFFFFF
POEG	-	-	-	POEGGB	POEG Group B Setting Register	0x100	32	R/W	0x00000000	0xFFFFFFFF
WDT	-	-	-	WDTRR	WDT Refresh Register	0x00	8	R/W	0xFF	0xFF
WDT	-	-	-	WDTCR	WDT Control Register	0x02	16	R/W	0x0000	0xFFFF
WDT	-	-	-	WDTSR	WDT Status Register	0x04	16	R/W	0x0000	0xFFFF
WDT	-	-	-	WDTRCR	WDT Reset Control Register	0x06	8	R/W	0x80	0xFF
WDT	-	-	-	WDTCSSTPR	WDT Count Stop Control Register	0x08	8	R/W	0x80	0xFF
IWDT	-	-	-	IWDTRR	IWDT Refresh Register	0x00	8	R/W	0xFF	0xFF
IWDT	-	-	-	IWDTSR	IWDT Status Register	0x04	16	R/W	0x0000	0xFFFF
CAC	-	-	-	CACR0	CAC Control Register 0	0x00	8	R/W	0x00	0xFF
CAC	-	-	-	CACR1	CAC Control Register 1	0x01	8	R/W	0x00	0xFF
CAC	-	-	-	CACR2	CAC Control Register 2	0x02	8	R/W	0x00	0xFF
CAC	-	-	-	CAICR	CAC Interrupt Control Register	0x03	8	R/W	0x00	0xFF
CAC	-	-	-	CASTR	CAC Status Register	0x04	8	R	0x00	0xFF
CAC	-	-	-	CAULVR	CAC Upper-Limit Value Setting Register	0x06	16	R/W	0x0000	0xFFFF
CAC	-	-	-	CALLVR	CAC Lower-Limit Value Setting Register	0x08	16	R/W	0x0000	0xFFFF
CAC	-	-	-	CACNTBR	CAC Counter Buffer Register	0x0A	16	R	0x0000	0xFFFF
MSTP	-	-	-	MSTPCRB	Module Stop Control Register B	0x000	32	R/W	0xFFFFFFFF	0xFFFFFFFF
MSTP	-	-	-	MSTPCRC	Module Stop Control Register C	0x004	32	R/W	0xFFFFFFFF	0xFFFFFFFF
MSTP	-	-	-	MSTPCRD	Module Stop Control Register D	0x008	32	R/W	0xFFFFFFFF	0xFFFFFFFF
I3C	-	-	-	PRTS	Protocol Selection Register	0x000	32	R/W	0x00000001	0xFFFFFFFF
I3C	-	-	-	BCTL	Bus Control Register	0x014	32	R/W	0xA000181	0xFFFFFFFF
I3C	-	-	-	MSDVAD	Master Device Address Register	0x018	32	R/W	0x807F0000	0xFFFFFFFF
I3C	-	-	-	RSTCTL	Reset Control Register	0x020	32	R/W	0x0001007F	0xFFFFFFFF
I3C	-	-	-	PRSST	Present State Register	0x024	32	R/W	0x00000004	0xFFFFFFFF
I3C	-	-	-	INST	Internal Status Register	0x030	32	R/W	0x00000000	0xFFFFFFFF
I3C	-	-	-	INSTE	Internal Status Enable Register	0x034	32	R/W	0x00000400	0xFFFFFFFF
I3C	-	-	-	INIE	Internal Interrupt Enable Register	0x038	32	R/W	0x00000400	0xFFFFFFFF
I3C	-	-	-	INSTFC	Internal Status Force Register	0x03C	32	R/W	0x00000000	0xFFFFFFFF
I3C	-	-	-	DVCT	Device Characteristic Table Register	0x044	32	R/W	0x00000000	0xFFFFFFFF
I3C	-	-	-	IBINCTL	IBI Notify Control Register	0x058	32	R/W	0x0000000B	0xFFFFFFFF
I3C	-	-	-	BFCTL	Bus Function Control Register	0x060	32	R/W	0x00000107	0xFFFFFFFF
I3C	-	-	-	SVCTL	Slave Control Register	0x064	32	R/W	0x00018061	0xFFFFFFFF
I3C	-	-	-	REFCKCTL	Reference Clock Control Register	0x070	32	R/W	0x00000007	0xFFFFFFFF

Table 3.4 Register description (6 of 11)

Peripheral name	Dim	Dim inc.	Dim index	Register name	Description	Address offset	Size	R/W	Reset value	Reset mask
I3C	-	-	-	STDBR	Standard Bit Rate Register	0x074	32	R/W	0xBF3FFFFFFF	0xFFFFFFFF
I3C	-	-	-	EXTBR	Extended Bit Rate Register	0x078	32	R/W	0x3F3FFFFFFF	0xFFFFFFFF
I3C	-	-	-	BFRECDT	Bus Free Condition Detection Time Register	0x07C	32	R/W	0x000001FF	0xFFFFFFFF
I3C	-	-	-	BAVLCDT	Bus Available Condition Detection Time Register	0x080	32	R/W	0x000001FF	0xFFFFFFFF
I3C	-	-	-	BIDLCDT	Bus Idle Condition Detection Time Register	0x084	32	R/W	0x0003FFFF	0xFFFFFFFF
I3C	-	-	-	OUTCTL	Output Control Register	0x088	32	R/W	0x00008713	0xFFFFFFFF
I3C	-	-	-	INCTL	Input Control Register	0x08C	32	R/W	0x000000DF	0xFFFFFFFF
I3C	-	-	-	TMOCTL	Timeout Control Register	0x090	32	R/W	0x000000F3	0xFFFFFFFF
I3C	-	-	-	ACKCTL	Acknowledge Control Register	0x0A0	32	R/W	0x00000002	0xFFFFFFFF
I3C	-	-	-	SCSTRCTL	SCL Stretch Control Register	0x0A4	32	R/W	0x00000003	0xFFFFFFFF
I3C	-	-	-	SCSTLCTL	SCL Stalling Control Register	0x0B0	32	R/W	0xF000FFFF	0xFFFFFFFF
I3C	-	-	-	SVTDLG0	Slave Transfer Data Length Register 0	0x0C0	32	R/W	0xFFFF0000	0xFFFFFFFF
I3C	-	-	-	CNDCTL	Condition Control Register	0x140	32	R/W	0x00000007	0xFFFFFFFF
I3C	-	-	-	NCMDQP	Normal Command Queue Port Register	0x150	32	R/W	0x00000000	0xFFFFFFFF
I3C	-	-	-	NRSPQP	Normal Response Queue Port Register	0x154	32	R/W	0x00000000	0xFFFFFFFF
I3C	-	-	-	NTDTBP0	Normal Transfer Data Buffer Port Register 0	0x158	32	R/W	0xFFFFFFFF	0xFFFFFFFF
I3C	-	-	-	NIBIQP	Normal IBI Queue Port Register	0x17C	32	R/W	0x00000000	0xFFFFFFFF
I3C	-	-	-	NRSQP	Normal Receive Status Queue Port Register	0x180	32	R/W	0x00000000	0xFFFFFFFF
I3C	-	-	-	NQTHCTL	Normal Queue Threshold Control Register	0x190	32	R/W	0xFFFFFFFF	0xFFFFFFFF
I3C	-	-	-	NTBTHCTL0	Normal Transfer Data Buffer Threshold Control Register 0	0x194	32	R/W	0x07070707	0xFFFFFFFF
I3C	-	-	-	NRQTHCTL	Normal Receive Status Queue Threshold Control Register	0x1C0	32	R/W	0x000000FF	0xFFFFFFFF
I3C	-	-	-	BST	Bus Status Register	0x1D0	32	R/W	0x00000000	0xFFFFFFFF
I3C	-	-	-	BSTE	Bus Status Enable Register	0x1D4	32	R/W	0x00110117	0xFFFFFFFF
I3C	-	-	-	BIE	Bus Interrupt Enable Register	0x1D8	32	R/W	0x00110117	0xFFFFFFFF
I3C	-	-	-	BSTFC	Bus Status Force Register	0x1DC	32	R/W	0x00000000	0xFFFFFFFF
I3C	-	-	-	NTST	Normal Transfer Status Register	0x1E0	32	R/W	0x00000000	0xFFFFFFFF
I3C	-	-	-	NTSTE	Normal Transfer Status Enable Register	0x1E4	32	R/W	0x0010023F	0xFFFFFFFF
I3C	-	-	-	NTIE	Normal Transfer Interrupt Enable Register	0x1E8	32	R/W	0x0010023F	0xFFFFFFFF
I3C	-	-	-	NTSTFC	Normal Transfer Status Force Register	0x1EC	32	R/W	0x00000000	0xFFFFFFFF
I3C	-	-	-	BCST	Bus Condition Status Register	0x210	32	R/W	0x00000000	0xFFFFFFFF
I3C	-	-	-	SVST	Slave Status Register	0x214	32	R/W	0x00000000	0xFFFFFFFF
I3C	-	-	-	DATBAS0	Device Address Table Basic Register 0	0x224	32	R/W	0xE0FFF07F	0xFFFFFFFF
I3C	-	-	-	DATBAS1	Device Address Table Basic Register 1	0x22C	32	R/W	0xE0FFF07F	0xFFFFFFFF
I3C	-	-	-	DATBAS2	Device Address Table Basic Register 2	0x234	32	R/W	0xE0FFF07F	0xFFFFFFFF
I3C	-	-	-	DATBAS3	Device Address Table Basic Register 3	0x23C	32	R/W	0xE0FFF07F	0xFFFFFFFF
I3C	-	-	-	EXDATBAS	Extended Device Address Table Basic Register	0x2A0	32	R/W	0xE0FF007F	0xFFFFFFFF
I3C	-	-	-	SDATBAS0	Slave Device Address Table Basic Register 0	0x2B0	32	R/W	0x007F07FF	0xFFFFFFFF
I3C	-	-	-	MSDCT0	Master Device Characteristic Table Register 0	0x2D0	32	R/W	0x0000FF00	0xFFFFFFFF
I3C	-	-	-	MSDCT1	Master Device Characteristic Table Register 1	0x2D4	32	R/W	0x0000FF00	0xFFFFFFFF

Table 3.4 Register description (7 of 11)

Peripheral name	Dim	Dim inc.	Dim index	Register name	Description	Address offset	Size	R/W	Reset value	Reset mask
I3C	-	-	-	MSDCT2	Master Device Characteristic Table Register 2	0x2D8	32	R/W	0x0000FF00	0xFFFFFFFF
I3C	-	-	-	MSDCT3	Master Device Characteristic Table Register 3	0x2DC	32	R/W	0x0000FF00	0xFFFFFFFF
I3C	-	-	-	SVDCT	Slave Device Characteristic Table Register	0x320	32	R/W	0x0000FFFF	0xFFFFFFFF
I3C	-	-	-	SDCTPIDL	Slave Device Characteristic Table Provisional ID Low Register	0x324	32	R/W	0x0000FFFF	0xFFFFFFFF
I3C	-	-	-	SDCTPIDH	Slave Device Characteristic Table Provisional ID High Register	0x328	32	R/W	0xFFFFFFFF	0xFFFFFFFF
I3C	-	-	-	SVDVAD0	Slave Device Address Register 0	0x330	32	R/W	0x00000000	0xFFFFFFFF
I3C	-	-	-	CSECMD	CCC Slave Events Command Register	0x350	32	R/W	0x0000000B	0xFFFFFFFF
I3C	-	-	-	CEACTST	CCC Enter Activity State Register	0x354	32	R/W	0x0000000F	0xFFFFFFFF
I3C	-	-	-	CMWLG	CCC Max Write Length Register	0x358	32	R/W	0x0000FFFF	0xFFFFFFFF
I3C	-	-	-	CMRLG	CCC Max Read Length Register	0x35C	32	R/W	0x00FFFFFF	0xFFFFFFFF
I3C	-	-	-	CETSTMD	CCC Enter Test Mode Register	0x360	32	R/W	0x00000000	0xFFFFFFFF
I3C	-	-	-	CGDVST	CCC Get Device Status Register	0x364	32	R/W	0x0000FFCF	0xFFFFFFFF
I3C	-	-	-	CMDSPW	CCC Max Data Speed W(Write) Register	0x368	32	R/W	0x00000007	0xFFFFFFFF
I3C	-	-	-	CMDSPR	CCC Max Data Speed R(Read) Register	0x36C	32	R/W	0x0000003F	0xFFFFFFFF
I3C	-	-	-	CMDSPR	CCC Max Data Speed T(Turnaround) Register	0x370	32	R/W	0x80FFFFFF	0xFFFFFFFF
I3C	-	-	-	CETSM	CCC Exchange Timing Support Information M(Mode) Register	0x374	32	R/W	0x00FFFF00	0xFFFFFFFF
I3C	-	-	-	BITCNT	Bit Count Register	0x380	32	R/W	0x0000001F	0xFFFFFFFF
I3C	-	-	-	NQSTLV	Normal Queue Status Level Register	0x394	32	R/W	0x00000000	0xFFFFFFFF
I3C	-	-	-	NDBSTLV0	Normal Data Buffer Status Level Register 0	0x398	32	R/W	0x00000000	0xFFFFFFFF
I3C	-	-	-	NRSQSTLV	Normal Receive Status Queue Status Level Register	0x3C0	32	R/W	0x00000000	0xFFFFFFFF
I3C	-	-	-	PRSTDBG	Present State Debug Register	0x3CC	32	R/W	0x00000000	0xFFFFFFFF
I3C	-	-	-	MSERRCNT	Master Error Counters Register	0x3D0	32	R/W	0x00000000	0xFFFFFFFF
DOC	-	-	-	DOCR	DOC Control Register	0x00	8	R/W	0x00	0xFF
DOC	-	-	-	DODIR	DOC Data Input Register	0x02	16	R/W	0x0000	0xFFFF
DOC	-	-	-	DODSR	DOC Data Setting Register	0x04	16	R/W	0x0000	0xFFFF
ADC12	-	-	-	ADCSR	A/D Control Register	0x000	16	R/W	0x0000	0xFFFF
ADC12	-	-	-	ADANSA0	A/D Channel Select Register A0	0x004	16	R/W	0x0000	0xFFFF
ADC12	-	-	-	ADANSA1	A/D Channel Select Register A1	0x006	16	R/W	0x0000	0xFFFF
ADC12	-	-	-	ADADS0	A/D-Converted Value Addition/Average Channel Select Register 0	0x008	16	R/W	0x0000	0xFFFF
ADC12	-	-	-	ADADS1	A/D-Converted Value Addition/Average Channel Select Register 1	0x00A	16	R/W	0x0000	0xFFFF
ADC12	-	-	-	ADADC	A/D-Converted Value Addition/Average Count Select Register	0x00C	8	R/W	0x00	0xFF
ADC12	-	-	-	ADCER	A/D Control Extended Register	0x00E	16	R/W	0x0000	0xFFFF
ADC12	-	-	-	ADSTRGR	A/D Conversion Start Trigger Select Register	0x010	16	R/W	0x0000	0xFFFF
ADC12	-	-	-	ADEXICR	A/D Conversion Extended Input Control Registers	0x012	16	R/W	0x0000	0xFFFF
ADC12	-	-	-	ADANSB0	A/D Channel Select Register B0	0x014	16	R/W	0x0000	0xFFFF
ADC12	-	-	-	ADANSB1	A/D Channel Select Register B1	0x016	16	R/W	0x0000	0xFFFF
ADC12	-	-	-	ADDBLDR	A/D Data Duplexing Register	0x018	16	R	0x0000	0xFFFF
ADC12	-	-	-	ADTSDR	A/D Temperature Sensor Data Register	0x01A	16	R	0x0000	0xFFFF

Table 3.4 Register description (8 of 11)

Peripheral name	Dim	Dim inc.	Dim index	Register name	Description	Address offset	Size	R/W	Reset value	Reset mask
ADC12	-	-	-	ADOCADR	A/D Internal Reference Voltage Data Register	0x01C	16	R	0x0000	0xFFFF
ADC12	-	-	-	ADRD	A/D Self-Diagnosis Data Register	0x01E	16	R	0x0000	0xFFFF
ADC12	4	0x2	5, 6, 9, 10	ADDR%s	A/D Data Registers %s	0x020	16	R	0x0000	0xFFFF
ADC12	4	0x2	19-22	ADDR%s	A/D Data Registers %s	0x042	16	R	0x0000	0xFFFF
ADC12	-	-	-	ADDISCR	A/D Disconnection Detection Control Register	0x07A	8	R/W	0x00	0xFF
ADC12	-	-	-	ADACSR	A/D Conversion Operation Mode Select Register	0x07E	8	R/W	0x00	0xFF
ADC12	-	-	-	ADGSPCR	A/D Group Scan Priority Control Register	0x080	16	R/W	0x0000	0xFFFF
ADC12	-	-	-	ADDBLDRA	A/D Data Duplexing Register A	0x084	16	R	0x0000	0xFFFF
ADC12	-	-	-	ADDBLDRB	A/D Data Duplexing Register B	0x086	16	R	0x0000	0xFFFF
ADC12	-	-	-	ADHVREFCNT	A/D High-Potential/Low-Potential Reference Voltage Control Register	0x08A	8	R/W	0x00	0xFF
ADC12	-	-	-	ADWINMON	A/D Compare Function Window A/B Status Monitor Register	0x08C	8	R	0x00	0xFF
ADC12	-	-	-	ADCMPCR	A/D Compare Function Control Register	0x090	16	R/W	0x0000	0xFFFF
ADC12	-	-	-	ADCMPANSER	A/D Compare Function Window A Extended Input Select Register	0x092	8	R/W	0x00	0xFF
ADC12	-	-	-	ADCMPLER	A/D Compare Function Window A Extended Input Comparison Condition Setting Register	0x093	8	R/W	0x00	0xFF
ADC12	-	-	-	ADCMPANSR0	A/D Compare Function Window A Channel Select Register 0	0x094	16	R/W	0x0000	0xFFFF
ADC12	-	-	-	ADCMPANSR1	A/D Compare Function Window A Channel Select Register 1	0x096	16	R/W	0x0000	0xFFFF
ADC12	-	-	-	ADCMPLR0	A/D Compare Function Window A Comparison Condition Setting Register 0	0x098	16	R/W	0x0000	0xFFFF
ADC12	-	-	-	ADCMPLR1	A/D Compare Function Window A Comparison Condition Setting Register 1	0x09A	16	R/W	0x0000	0xFFFF
ADC12	2	0x2	0-1	ADCMPDR%s	A/D Compare Function Window A Lower-Side/Upper-Side Level Setting Register	0x09C	16	R/W	0x0000	0xFFFF
ADC12	-	-	-	ADCMPSR0	A/D Compare Function Window A Channel Status Register 0	0x0A0	16	R/W	0x0000	0xFFFF
ADC12	-	-	-	ADCMPSR1	A/D Compare Function Window A Channel Status Register 1	0x0A2	16	R/W	0x0000	0xFFFF
ADC12	-	-	-	ADCMPSESR	A/D Compare Function Window A Extended Input Channel Status Register	0x0A4	8	R/W	0x00	0xFF
ADC12	-	-	-	ADCMPBNSR	A/D Compare Function Window B Channel Select Register	0x0A6	8	R/W	0x00	0xFF
ADC12	-	-	-	ADWINLLB	A/D Compare Function Window B Lower-Side/Upper-Side Level Setting Register	0x0A8	16	R/W	0x0000	0xFFFF
ADC12	-	-	-	ADWINULB	A/D Compare Function Window B Lower-Side/Upper-Side Level Setting Register	0x0AA	16	R/W	0x0000	0xFFFF
ADC12	-	-	-	ADCMPBSR	A/D Compare Function Window B Status Register	0x0AC	8	R/W	0x00	0xFF
ADC12	-	-	-	ADSSTRL	A/D Sampling State Register	0x0DD	8	R/W	0x0D	0xFF
ADC12	-	-	-	ADSSTR	A/D Sampling State Register	0x0DE	8	R/W	0x0D	0xFF
ADC12	-	-	-	ADSSTRO	A/D Sampling State Register	0x0DF	8	R/W	0x0D	0xFF
ADC12	4	0x1	5, 6, 9, 10	ADSSTR%s	A/D Sampling State Register	0x0E0	8	R/W	0x0D	0xFF
SCI9	-	-	-	SMR	Serial Mode Register for Non-Smart Card Interface Mode (SCMR.SMIF = 0)	0x00	8	R/W	0x00	0xFF
SCI9	-	-	-	SMR_SMCI	Serial Mode Register for Smart Card Interface Mode (SCMR.SMIF = 1)	0x00	8	R/W	0x00	0xFF
SCI9	-	-	-	BRR	Bit Rate Register	0x01	8	R/W	0xFF	0xFF

Table 3.4 Register description (9 of 11)

Peripheral name	Dim	Dim inc.	Dim index	Register name	Description	Address offset	Size	R/W	Reset value	Reset mask
SCI9	-	-	-	SCR	Serial Control Register for Non-Smart Card Interface Mode (SCMR.SMIF = 0)	0x02	8	R/W	0x00	0xFF
SCI9	-	-	-	SCR_SMC1	Serial Control Register for Smart Card Interface Mode (SCMR.SMIF = 1)	0x02	8	R/W	0x00	0xFF
SCI9	-	-	-	TDR	Transmit Data Register	0x03	8	R/W	0xFF	0xFF
SCI9	-	-	-	SSR	Serial Status Register for Non-Smart Card Interface and Non-FIFO Mode (SCMR.SMIF = 0 and FCR.FM = 0)	0x04	8	R/W	0x84	0xFF
SCI9	-	-	-	SSR_SMC1	Serial Status Register for Smart Card Interface Mode (SCMR.SMIF = 1)	0x04	8	R/W	0x84	0xFF
SCI9	-	-	-	RDR	Receive Data Register	0x05	8	R/W	0x00	0xFF
SCI9	-	-	-	SCMR	Smart Card Mode Register	0x06	8	R/W	0xF2	0xFF
SCI9	-	-	-	SEMR	Serial Extended Mode Register	0x07	8	R/W	0x00	0xFF
SCI9	-	-	-	SNFR	Noise Filter Setting Register	0x08	8	R/W	0x00	0xFF
SCI9	-	-	-	SIMR1	IIC Mode Register 1	0x09	8	R/W	0x00	0xFF
SCI9	-	-	-	SIMR2	IIC Mode Register 2	0x0A	8	R/W	0x00	0xFF
SCI9	-	-	-	SIMR3	IIC Mode Register 3	0x0B	8	R/W	0x00	0xFF
SCI9	-	-	-	SISR	IIC Status Register	0x0C	8	R	0x00	0xCB
SCI9	-	-	-	SPMR	SPI Mode Register	0x0D	8	R/W	0x00	0xFF
SCI9	-	-	-	TDRHL	Transmit Data Register	0x0E	16	R/W	0xFFFF	0xFFFF
SCI9	-	-	-	RDRHL	Receive Data Register	0x10	16	R	0x0000	0xFFFF
SCI9	-	-	-	MDDR	Modulation Duty Register	0x12	8	R/W	0xFF	0xFF
SCI9	-	-	-	DCCR	Data Compare Match Control Register	0x13	8	R/W	0x40	0xFF
SCI9	-	-	-	CDR	Compare Match Data Register	0x1A	16	R/W	0x0000	0xFFFF
SCI9	-	-	-	SPTR	Serial Port Register	0x1C	8	R/W	0x03	0xFF
SPI0	-	-	-	SPCR	SPI Control Register	0x00	8	R/W	0x00	0xFF
SPI0	-	-	-	SSLP	SPI Slave Select Polarity Register	0x01	8	R/W	0x00	0xFF
SPI0	-	-	-	SPPCR	SPI Pin Control Register	0x02	8	R/W	0x00	0xFF
SPI0	-	-	-	SPSR	SPI Status Register	0x03	8	R/W	0x20	0xFF
SPI0	-	-	-	SPDR	SPI Data Register	0x04	32	R/W	0x00000000	0xFFFFFFFF
SPI0	-	-	-	SPDR_HA	SPI Data Register	0x04	16	R/W	0x0000	0xFFFF
SPI0	-	-	-	SPBR	SPI Bit Rate Register	0x0A	8	R/W	0xFF	0xFF
SPI0	-	-	-	SPDCR	SPI Data Control Register	0x0B	8	R/W	0x00	0xFF
SPI0	-	-	-	SPCKD	SPI Clock Delay Register	0x0C	8	R/W	0x00	0xFF
SPI0	-	-	-	SSLND	SPI Slave Select Negation Delay Register	0x0D	8	R/W	0x00	0xFF
SPI0	-	-	-	SPND	SPI Next-Access Delay Register	0x0E	8	R/W	0x00	0xFF
SPI0	-	-	-	SPCR2	SPI Control Register 2	0x0F	8	R/W	0x00	0xFF
SPI0	-	-	-	SPCMD0	SPI Command Register 0	0x10	16	R/W	0x070D	0xFFFF
CRC	-	-	-	CRCCR0	CRC Control Register 0	0x00	8	R/W	0x00	0xFF
CRC	-	-	-	CRCCR1	CRC Control Register 1	0x01	8	R/W	0x00	0xFF
CRC	-	-	-	CRCDIR	CRC Data Input Register	0x04	32	R/W	0x00000000	0xFFFFFFFF
CRC	-	-	-	CRCDIR_BY	CRC Data Input Register	0x04	8	R/W	0x00	0xFF
CRC	-	-	-	CRCDOR	CRC Data Output Register	0x08	32	R/W	0x00000000	0xFFFFFFFF
CRC	-	-	-	CRCDOR_HA	CRC Data Output Register	0x08	16	R/W	0x0000	0xFFFF
CRC	-	-	-	CRCDOR_BY	CRC Data Output Register	0x08	8	R/W	0x00	0xFF
CRC	-	-	-	CRCSAR	Snoop Address Register	0x0C	16	R/W	0x0000	0xFFFF
GPT164-9	-	-	-	GTWP	General PWM Timer Write-Protection Register	0x00	32	R/W	0x00000000	0xFFFFFFFF

Table 3.4 Register description (10 of 11)

Peripheral name	Dim	Dim inc.	Dim index	Register name	Description	Address offset	Size	R/W	Reset value	Reset mask
GPT164-9	-	-	-	GTSTR	General PWM Timer Software Start Register	0x04	32	R/W	0x00000000	0xFFFFFFFF
GPT164-9	-	-	-	GTSTP	General PWM Timer Software Stop Register	0x08	32	R/W	0xFFFFFFFF	0xFFFFFFFF
GPT164-9	-	-	-	GTCLR	General PWM Timer Software Clear Register	0x0C	32	W	0x00000000	0xFFFFFFFF
GPT164-9	-	-	-	GTSSR	General PWM Timer Start Source Select Register	0x10	32	R/W	0x00000000	0xFFFFFFFF
GPT164-9	-	-	-	GTSPSR	General PWM Timer Stop Source Select Register	0x14	32	R/W	0x00000000	0xFFFFFFFF
GPT164-9	-	-	-	GTCSR	General PWM Timer Clear Source Select Register	0x18	32	R/W	0x00000000	0xFFFFFFFF
GPT164-9	-	-	-	GTUPSR	General PWM Timer Up Count Source Select Register	0x1C	32	R/W	0x00000000	0xFFFFFFFF
GPT164-9	-	-	-	GTDNSR	General PWM Timer Down Count Source Select Register	0x20	32	R/W	0x00000000	0xFFFFFFFF
GPT164-9	-	-	-	GTICASR	General PWM Timer Input Capture Source Select Register A	0x24	32	R/W	0x00000000	0xFFFFFFFF
GPT164-9	-	-	-	GTICBSR	General PWM Timer Input Capture Source Select Register B	0x28	32	R/W	0x00000000	0xFFFFFFFF
GPT164-9	-	-	-	GTCR	General PWM Timer Control Register	0x2C	32	R/W	0x00000000	0xFFFFFFFF
GPT164-9	-	-	-	GTUDDTYC	General PWM Timer Count Direction and Duty Setting Register	0x30	32	R/W	0x00000001	0xFFFFFFFF
GPT164-9	-	-	-	GTIOR	General PWM Timer I/O Control Register	0x34	32	R/W	0x00000000	0xFFFFFFFF
GPT164-9	-	-	-	GTINTAD	General PWM Timer Interrupt Output Setting Register	0x38	32	R/W	0x00000000	0xFFFFFFFF
GPT164-9	-	-	-	GTST	General PWM Timer Status Register	0x3C	32	R/W	0x00008000	0xFFFFFFFF
GPT164-9	-	-	-	GTBER	General PWM Timer Buffer Enable Register	0x40	32	R/W	0x00000000	0xFFFFFFFF
GPT164-9	-	-	-	GTCNT	General PWM Timer Counter	0x48	32	R/W	0x00000000	0xFFFFFFFF
GPT164-9	-	-	-	GTCCRA	General PWM Timer Compare Capture Register A	0x4C	32	R/W	0xFFFFFFFF	0xFFFFFFFF
GPT164-9	-	-	-	GTCCRB	General PWM Timer Compare Capture Register B	0x50	32	R/W	0xFFFFFFFF	0xFFFFFFFF
GPT164-9	-	-	-	GTCCRC	General PWM Timer Compare Capture Register C	0x54	32	R/W	0xFFFFFFFF	0xFFFFFFFF
GPT164-9	-	-	-	GTCCRE	General PWM Timer Compare Capture Register E	0x58	32	R/W	0xFFFFFFFF	0xFFFFFFFF
GPT164-9	-	-	-	GTCCRD	General PWM Timer Compare Capture Register D	0x5C	32	R/W	0xFFFFFFFF	0xFFFFFFFF
GPT164-9	-	-	-	GTCCRF	General PWM Timer Compare Capture Register F	0x60	32	R/W	0xFFFFFFFF	0xFFFFFFFF
GPT164-9	-	-	-	GTPR	General PWM Timer Cycle Setting Register	0x64	32	R/W	0xFFFFFFFF	0xFFFFFFFF
GPT164-9	-	-	-	GTPBR	General PWM Timer Cycle Setting Buffer Register	0x68	32	R/W	0xFFFFFFFF	0xFFFFFFFF
GPT164-9	-	-	-	GTDTCR	General PWM Timer Dead Time Control Register	0x88	32	R/W	0x00000000	0xFFFFFFFF
GPT164-9	-	-	-	GTDVU	General PWM Timer Dead Time Value Register U	0x8C	32	R/W	0xFFFFFFFF	0xFFFFFFFF
GPT_0PS	-	-	-	OPSCR	Output Phase Switching Control Register	0x00	32	R/W	0x00000000	0xFFFFFFFF
KINT	-	-	-	KRCTL	Key Return Control Register	0x00	8	R/W	0x00	0xFF
KINT	-	-	-	KRF	Key Return Flag Register	0x04	8	R/W	0x00	0xFF
KINT	-	-	-	KRM	Key Return Mode Register	0x08	8	R/W	0x00	0xFF
AGTW0-1	-	-	-	AGT	AGT Counter Register	0x00	32	R/W	0xFFFFFFFF	0xFFFFFFFF

Table 3.4 Register description (11 of 11)

Peripheral name	Dim	Dim inc.	Dim index	Register name	Description	Address offset	Size	R/W	Reset value	Reset mask
AGTW0-1	-	-	-	AGTCMB	AGT Compare Match B Register	0x08	32	R/W	0xFFFFFFFF	0xFFFFFFFF
AGTW0-1	-	-	-	AGTCMA	AGT Compare Match A Register	0x04	32	R/W	0xFFFFFFFF	0xFFFFFFFF
AGTW0-1	-	-	-	AGTCR	AGT Control Register	0x0C	8	R/W	0x00	0xFF
AGTW0-1	-	-	-	AGTMR1	AGT Mode Register 1	0x0D	8	R/W	0x00	0xFF
AGTW0-1	-	-	-	AGTMR2	AGT Mode Register 2	0x0E	8	R/W	0x00	0xFF
AGTW0-1	-	-	-	AGTIOC	AGT I/O Control Register	0x10	8	R/W	0x00	0xFF
AGTW0-1	-	-	-	AGTISR	AGT Event Pin Select Register	0x11	8	R/W	0x00	0xFF
AGTW0-1	-	-	-	AGTCMSR	AGT Compare Match Function Select Register	0x12	8	R/W	0x00	0xFF
AGTW0-1	-	-	-	AGTIOSEL	AGT Pin Select Register	0x00F	8	R/W	0x00	0xFF
FLCN	-	-	-	DFLCTL	Data Flash Enable Register	0x0090	8	R/W	0x00	0xFF
FLCN	-	-	-	TSCDR	Temperature Sensor Calibration Data Register	0x0228	16	R	Unique value for each chip	0x0000
FLCN	-	-	-	FLDWAITR	Memory Wait Cycle Control Register for Data Flash	0x3FC4	8	R/W	0x00	0xFF
FLCN	-	-	-	PFBER	Prefetch Buffer Enable Register	0x3FC8	8	R/W	0x00	0xFF

Note: Peripheral name = Name of peripheral
 Dim = Number of elements in an array of registers
 Dim inc. = Address increment between two simultaneous registers of a register array in the address map
 Dim index = Sub string that replaces the %s placeholder within the register name
 Register name = Name of register
 Description = Register description
 Address offset = Address of the register relative to the base address defined by the peripheral of the register
 Size = Bit width of the register
 Reset value = Default reset value of a register
 Reset mask = Identifies which register bits have a defined reset value

Revision History

Revision 1.00 — August 18, 2021

First edition, issued

Revision 1.10 — March 31, 2022**1. Overview:**

- Added Table 1.10 I/O ports.
- Updated Figure 1.2 Part numbering scheme.
- Updated Table 1.11 Product list.
- Updated Figure 1.3 Pin assignment for HWQFN 24-pin (top view).
- Updated Figure 1.4 Pin assignment for HWQFN 20-pin (top view).

36. Electrical Characteristics:

- Updated Table 2.4 I/O V_{IH} , V_{IL} .
- Updated Note 2 in Table 2.49 Power-on reset circuit and voltage detection circuit characteristics (1).

APP2. Appendix 2. Package Dimensions:

- Updated Figure 2.1 HWQFN 24-pin.
- Updated Figure 2.2 HWQFN 20-pin.

APP3. Appendix 3. I/O Registers:

- Updated Table 3.2 Access cycles for non-GPT modules.

Revision 1.20 — November 30, 2022**1. Overview:**

- Updated Figure 1.2 Part numbering scheme.
- Updated Table 1.12 Function Comparison.

2. Electrical Characteristics:

- Updated Table 2.32 SPI timing.
- Updated 2.7.1 Code Flash Memory Characteristics and 2.7.2 Data Flash Memory Characteristics.

Appendix 3. I/O Registers:

- Updated Table 3.4 Register description.

General Precautions in the Handling of Microprocessing Unit and Microcontroller Unit Products

The following usage notes are applicable to all Microprocessing unit and Microcontroller unit products from Renesas. For detailed usage notes on the products covered by this document, refer to the relevant sections of the document as well as any technical updates that have been issued for the products.

1. Precaution against Electrostatic Discharge (ESD)

A strong electrical field, when exposed to a CMOS device, can cause destruction of the gate oxide and ultimately degrade the device operation. Steps must be taken to stop the generation of static electricity as much as possible, and quickly dissipate it when it occurs. Environmental control must be adequate. When it is dry, a humidifier should be used. This is recommended to avoid using insulators that can easily build up static electricity.

Semiconductor devices must be stored and transported in an anti-static container, static shielding bag or conductive material. All test and measurement tools including work benches and floors must be grounded. The operator must also be grounded using a wrist strap. Semiconductor devices must not be touched with bare hands. Similar precautions must be taken for printed circuit boards with mounted semiconductor devices.

2. Processing at power-on

The state of the product is undefined at the time when power is supplied. The states of internal circuits in the LSI are indeterminate and the states of register settings and pins are undefined at the time when power is supplied. In a finished product where the reset signal is applied to the external reset pin, the states of pins are not guaranteed from the time when power is supplied until the reset process is completed. In a similar way, the states of pins in a product that is reset by an on-chip power-on reset function are not guaranteed from the time when power is supplied until the power reaches the level at which resetting is specified.

3. Input of signal during power-off state

Do not input signals or an I/O pull-up power supply while the device is powered off. The current injection that results from input of such a signal or I/O pull-up power supply may cause malfunction and the abnormal current that passes in the device at this time may cause degradation of internal elements. Follow the guideline for input signal during power-off state as described in your product documentation.

4. Handling of unused pins

Handle unused pins in accordance with the directions given under handling of unused pins in the manual. The input pins of CMOS products are generally in the high-impedance state. In operation with an unused pin in the open-circuit state, extra electromagnetic noise is induced in the vicinity of the LSI, an associated shoot-through current flows internally, and malfunctions occur due to the false recognition of the pin state as an input signal become possible.

5. Clock signals

After applying a reset, only release the reset line after the operating clock signal becomes stable. When switching the clock signal during program execution, wait until the target clock signal is stabilized. When the clock signal is generated with an external resonator or from an external oscillator during a reset, ensure that the reset line is only released after full stabilization of the clock signal. Additionally, when switching to a clock signal produced with an external resonator or by an external oscillator while program execution is in progress, wait until the target clock signal is stable.

6. Voltage application waveform at input pin

Waveform distortion due to input noise or a reflected wave may cause malfunction. If the input of the CMOS device stays in the area between V_{IL} (Max.) and V_{IH} (Min.) due to noise, for example, the device may malfunction. Take care to prevent chattering noise from entering the device when the input level is fixed, and also in the transition period when the input level passes through the area between V_{IL} (Max.) and V_{IH} (Min.).

7. Prohibition of access to reserved addresses

Access to reserved addresses is prohibited. The reserved addresses are provided for possible future expansion of functions. Do not access these addresses as the correct operation of the LSI is not guaranteed.

8. Differences between products

Before changing from one product to another, for example to a product with a different part number, confirm that the change will not lead to problems. The characteristics of a microprocessing unit or microcontroller unit products in the same group but having a different part number might differ in terms of internal memory capacity, layout pattern, and other factors, which can affect the ranges of electrical characteristics, such as characteristic values, operating margins, immunity to noise, and amount of radiated noise. When changing to a product with a different part number, implement a system-evaluation test for the given product.