

# HIGH FREQUENCY PLANAR TRANSFORMERS

Industrial Grade



- ⊗ Power Rating: up to 250W
- ⊗ Height: 9.1mm to 10.4mm max
- ⊗ Footprint: 29.5mm x 26.7mm Max
- ⊗ Frequency Range: 200kHz to 700kHz
- ⊗ Isolation (Primary to Secondary): 1750V<sub>DC</sub>

## Electrical Specifications @ 25 °C – Operating Temperature – 40°C to +125 °C

Part Number	Turns Ratio		Schematic	Primary* Inductance (µH MIN)	Leakage** Inductance (µH MAX)	DCR (mΩ MAX)				Height MAX (mm)
	Primary	Secondary				Primary A	Primary B	Primary Aux.	Secondary	
<b>DOUBLE INTERLEAVE DESIGNS (HIGHER EFFICIENCY, LOWER DCR AND LOWER LEAKAGE)</b>										
R8201NL	4T & 4T	4T (1T:1T:1T:1T)	A1	216	0.3	13	13	—	4.5	10.2
R8203NL	5T & 5T (w/5T aux)			340	0.2	15	15	235		
R8205NL	6T & 6T (w/2T aux)			480	0.35	21	21	78		
R8207NL	7T & 7T (w/3T aux)			660	0.45	50	50	100		
R8209NL	8T & 8T			860	0.5	45	45	—		
R8208NL	4T & 4T	1T & 1T	A2	216	0.2	13	13	—	0.56 & 0.56	10.2
R8210NL	5T & 5T (w/5T aux)			340	0.3	15	15	235		
R8212NL	6T & 6T (w/2T aux)			480	0.35	21	21	78		
R8214NL	7T & 7T (w/3T aux)			660	0.45	50	50	100		
R8216NL	8T & 8T			860	0.5	45	45	—		
<b>SINGLE INTERLEAVE DESIGNS</b>										
R8230NL	4T	4T (1T:1T:1T:1T)	B1	54	0.2	13	—	—	4.5	9.1
R8231NL	5T (w/5T aux)			85	0.3	15	—	470		
R8232NL	6T (w/2T aux)			120	0.35	21	—	160		
R8233NL	7T (w/3T aux)			165	0.45	50	—	200		
R8246NL	8T			215	0.5	45	—	—		
R8234NL	4T	7T & 7T	B2	54	0.2	13	—	—	40 & 40	9.1
R8235NL	5T (w/5T aux)			85	0.3	15	—	470		
R8236NL	6T (w/2T aux)			120	0.35	21	—	160		
R8237NL	7T (w/3T aux)			165	0.45	50	—	200		
R8247NL	8T			215	0.5	45	—	—		
R8238NL	4T	1T & 1T	B2	54	0.2	13	—	—	1.12 & 1.12	9.1
R8239NL	5T (w/5T aux)			85	0.3	15	—	470		
R8240NL	6T (w/2T aux)			120	0.35	21	—	160		
R8241NL	7T (w/3T aux)			165	0.45	50	—	200		
R8248NL	8T			215	0.5	45	—	—		
R8242NL	4T	2T & 1T	B3	54	0.2	13	—	—	1.8 & 0.6	9.1
R8243NL	5T (w/5T aux)			85	0.3	15	—	470		
R8244NL	6T (w/2T aux)			120	0.35	21	—	160		
R8245NL	7T (w/3T aux)			165	0.45	50	—	200		
R8249NL	8T			215	0.5	45	—	—		

**Notes:** 1. Option Tape & Reel packaging can be ordered by adding a "T" suffix at the end of the part number (i.e. R8235NLT).



## Mechanicals

NOTE: The below is a universal footprint for a component that has all 11 pins populated. For a given part number it is only necessary to provide pads for the terminations shown

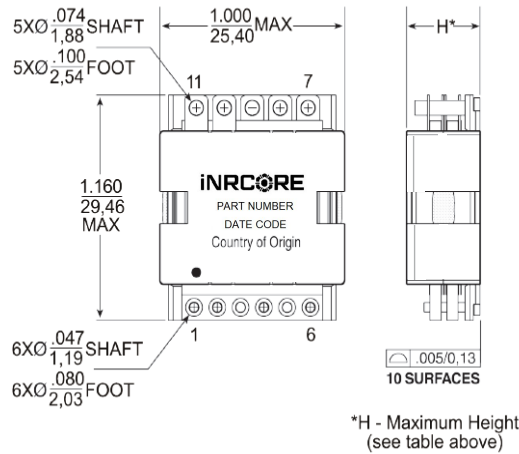

### SUGGESTED PAD LAYOUT

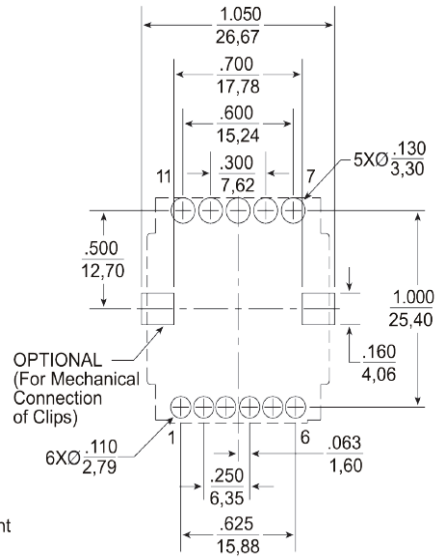

## Electrical Schematics

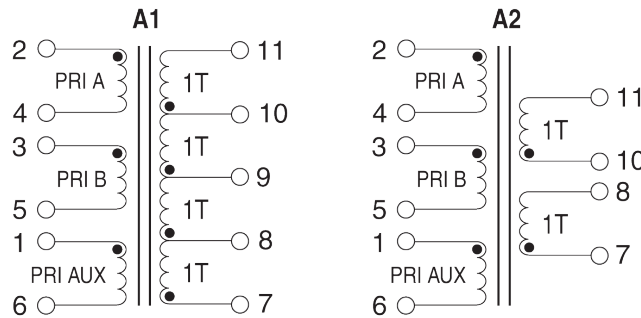

### — SINGLE INTERLEAVE SCHEMATICS —

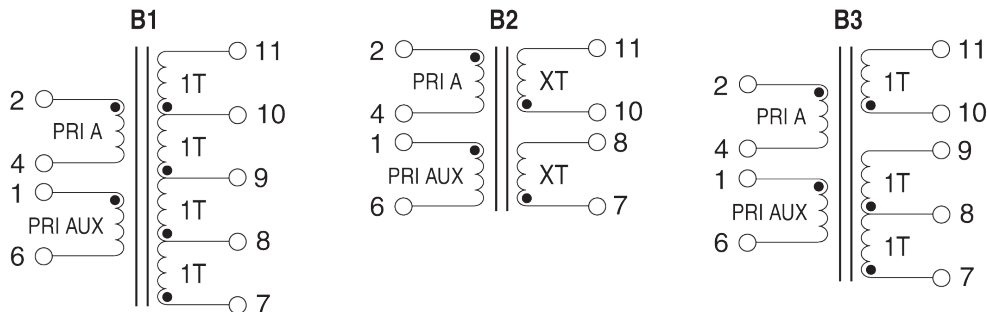

## R82XXNL Transformer Winding Configuration Matrix

The following is a matrix of the winding configurations that are possible with the iNRCORE R82XXNL Planar Transformer Platform. The package is typically capable of handling between 150-250W of power depending on the application, ambient conditions and available cooling.

Once a configuration is selected, the formulae and charts can be used to determine the approximate power dissipation and temperature rise of the component in a given application.

High Efficiency Double Interleaved Designs										
			SECONDARY WINDINGS							
			Single Winding			Tapped Winding			Dual Winding	
			Turns	1T	2T	4T	1:1	1:3	2:2	1T & 1T
			DCR (mΩ)	0.28	1.12	4.5	1.12	4.5	4.5	1.12
PRIMARY WINDINGS	Single Winding	4T	5	R8208NL	R8208NL	R8201NL	R8208NL	R8201NL	R8201NL	R8208NL
		5T	7.5	R8210NL	R8210NL	R8203NL	R8210NL	R8203NL	R8203NL	R8210NL
		6T	12	R8212NL	R8212NL	R8205NL	R8212NL	R8205NL	R8205NL	R8212NL
		7T	30	R8214NL	R8214NL	R8207NL	R8214NL	R8207NL	R8207NL	R8214NL
		8T	20	R8208NL	R8208NL	R8201NL	R8208 NL	R8201NL	R8201NL	R8208NL
		10T	30	R8210NL	R8210NL	R8203NL	R8210NL	R8203NL	R8203NL	R8210NL
		12T	48	R8212NL	R8212NL	R8205NL	R8212NL	R8205NL	R8205NL	R8212NL
		14T	120	R8214NL	R8214NL	R8207NL	R8214NL	R8207NL	R8207NL	R8214NL
	16T	140	R8216NL	R8216NL	R8209NL	R8216NL	R8209NL	R8209NL	R8216NL	
	Dual Winding	4T & 4T	20	R8208NL	R8208NL	R8201NL	R8208NL	R8201NL	R8201NL	R8208NL
		5T & 5T	30	R8210NL	R8210NL	R8203NL	R8210NL	R8203NL	R8203NL	R8210NL
		6T & 6T	48	R8212NL	R8212NL	R8205NL	R8212NL	R8205NL	R8205NL	R8212NL
		7T & 7T	120	R8214NL	R8214NL	R8207NL	R8214NL	R8207NL	R8207NL	R8214NL
		8T & 8T	140	R8216NL	R8216NL	R8209NL	R8216NL	R8209NL	R8209NL	R8216NL

Lower Cost Single Interleaved Designs																
			SECONDARY WINDINGS													
			Single Winding					Tapped Winding					Dual Winding			
			Turns	1T	2T	3T	4T	7T	1:1	1:2	1:3	2:2	7:7	1T & 1T	1T & 2T	7T & 7T
			DCR (mΩ)	0.56	2.24	3.4	4.5	20	2.24	3.4	4.5	4.5	80	2.24	4.5	80
PRIMARY WINDINGS	Single Winding	4T	10	R8238NL	R8238NL	R8242NL	R8230NL	R8234NL	R8238NL	R8242NL	R8230NL	R8230NL	R8234NL	R8238NL	R8242NL	R8234NL
		5T	15	R8239NL	R8239NL	R8243NL	R8231NL	R8235NL	R8239NL	R8243NL	R8231NL	R8231NL	R8235NL	R8239NL	R8243NL	R8235NL
		6T	24	R8240NL	R8240NL	R8244 NL	R8232NL	R8236NL	R8240NL	R8244NL	R8232NL	R8232NL	R8236NL	R8240NL	R8244NL	R8236NL
		7T	60	R8241NL	R8241NL	R8245NL	R8233NL	R8237NL	R8241NL	R8245NL	R8233NL	PR8233NL	R8237NL	R8241NL	R8245NL	R8237NL
		8T	70	R8248NL	R8248NL	R8249NL	PR8246NL	R8247NL	R8248NL	R8249NL	R8246NL	R8246NL	R8247NL	R8248NL	R8249NL	R8247NL

NOTES: 1. The base PN (ie: R8201NL) uses an ungapped core. The minimum primary inductance for any configuration can be calculated as:

$$\text{Primary Inductance } (\mu\text{H Min}) = 3.4 * (\text{Primary Turns})^2$$

2. The above base part numbers (R82XXNL) are available from stock

3. It is possible to add a small gap to the transformer. Gapped transformers are non-standard and can be made available upon request, but are not typically available from stock. To request a gapped version of the transformer, add a suffix "G" to the base number (ie: **R8201GNL**). The nominal inductance with a gap can be calculated as:

$$\text{Primary Inductance } (\mu\text{H Nominal}) = 2.2 * (\text{Primary Turns})^2$$

