

F5268

26GHz 8-Channel, Half-Duplex Transceiver IC

The F5268 is an 8-channel half-duplex transceiver (TRX) silicon integrated circuit (IC). The device is designed using a SiGe BiCMOS process for dual-polarization 5G phased-array applications at n258 and n261 bands. The core IC has highly flexible gain and phase control on each channel to achieve fine beam steering and gain compensation between radiating channels.

The F5268 includes a standard SPI protocol that operates up to 65MHz with fast beam switching and fast beam-state loading. Up to 16 devices can be supported on the same SPI bus using dedicated address pins. Each device uses a 2.5V analog supply and a selectable 2.5V/3.3V PA supply to provide dual TX power modes. The digital core and SPI use a 1.8V supply generated by an on-chip LDO.

Block Diagram

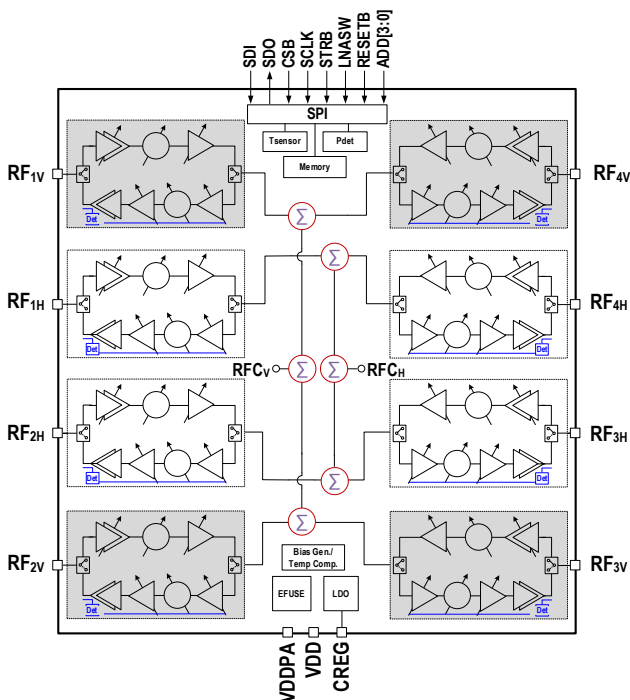

Features

- 24.25 - 27.5GHz operation (5G NR n258/n261)
- 8 radiation channels
- 100ns typical TX/RX mode switching time
- 20ns typical gain and phase settling time
- 1.4° typical RMS phase error
- 0.2dB typical RMS gain error
- 30.5dB gain attenuation range
- Integrated PTAT, PTAT2, and Bandgap generator
- Internal temperature sensor and power detector
- 4-bit chip address (hard-wired/programmable)
- Up to 65MHz SPI control
- 2048 on-chip programmable beam states
- Analog supply voltage: +2.4V to +2.6V
- Dedicated PA supply voltage: selectable between +2.4V to +2.6V and +3.0V to +3.3V
- 5.1 × 5.1 × 0.8 mm, 118-FCCSP package
- -40°C to +95°C operating temperature range

Applications

- 5G Single/Dual-Polarization Phased-Array Antenna System
- Beam Steering

Ordering Information

Part Number	Package (mm)	Carrier Type
RA81F5268STGBX#BC0	5.1 × 5.1 × 0.8 118-FCCSP	Tray
RA81F5268STGBX#KC0	5.1 × 5.1 × 0.8 118-FCCSP	Reel
RTKA81F5268ST000RU	Eval. Board	-

IMPORTANT NOTICE AND DISCLAIMER

RENESAS ELECTRONICS CORPORATION AND ITS SUBSIDIARIES (“RENESAS”) PROVIDES TECHNICAL SPECIFICATIONS AND RELIABILITY DATA (INCLUDING DATASHEETS), DESIGN RESOURCES (INCLUDING REFERENCE DESIGNS), APPLICATION OR OTHER DESIGN ADVICE, WEB TOOLS, SAFETY INFORMATION, AND OTHER RESOURCES “AS IS” AND WITH ALL FAULTS, AND DISCLAIMS ALL WARRANTIES, EXPRESS OR IMPLIED, INCLUDING, WITHOUT LIMITATION, ANY IMPLIED WARRANTIES OF MERCHANTABILITY, FITNESS FOR A PARTICULAR PURPOSE, OR NON-INFRINGEMENT OF THIRD PARTY INTELLECTUAL PROPERTY RIGHTS.

These resources are intended for developers skilled in the art designing with Renesas products. You are solely responsible for (1) selecting the appropriate products for your application, (2) designing, validating, and testing your application, and (3) ensuring your application meets applicable standards, and any other safety, security, or other requirements. These resources are subject to change without notice. Renesas grants you permission to use these resources only for development of an application that uses Renesas products. Other reproduction or use of these resources is strictly prohibited. No license is granted to any other Renesas intellectual property or to any third party intellectual property. Renesas disclaims responsibility for, and you will fully indemnify Renesas and its representatives against, any claims, damages, costs, losses, or liabilities arising out of your use of these resources. Renesas' products are provided only subject to Renesas' Terms and Conditions of Sale or other applicable terms agreed to in writing. No use of any Renesas resources expands or otherwise alters any applicable warranties or warranty disclaimers for these products.

(Rev.1.0 Mar 2020)

Corporate Headquarters

TOYOSU FORESIA, 3-2-24 Toyosu,
Koto-ku, Tokyo 135-0061, Japan
www.renesas.com

Contact Information

For further information on a product, technology, the most up-to-date version of a document, or your nearest sales office, please visit:
www.renesas.com/contact/

Trademarks

Renesas and the Renesas logo are trademarks of Renesas Electronics Corporation. All trademarks and registered trademarks are the property of their respective owners.