

RAA215300

High Performance 9-Channel PMIC Supporting DDR Memory, with Built-In Charger and RTC

The RAA215300 is a high-performance, low-cost 9-channel PMIC designed for 32-bit and 64-bit MCU and MPU applications. It supports DDR3, DDR3L, DDR4, and LPDDR4 memory power requirements. The internally compensated regulators, built-in Real-Time Clock (RTC), 32kHz crystal oscillator, and coin cell battery charger provide a highly integrated, small footprint power solution ideal for System-On-Module (SOM) applications. A spread spectrum feature provides an ease-of-use solution for noise-sensitive audio or RF applications.

The RAA215300 has six high-efficiency buck regulators and three LDOs to provide a complete power system. The internal device registers and EEPROM can configure and optimize the RAA215300 for different application requirements, for example, power sequences, output voltages, and switching frequencies. Dynamic Voltage Scaling (DVS) and Sleep modes are supported.

The RAA215300 is available in an 8x8mm, 0.5mm pitch thermally enhanced 56-lead QFN package and is specified for operation across a -40°C to 105°C ambient and -40°C to 125°C junction temperature range.

Features

- Input operating voltage range: 2.7V~5.5V
- 6 synchronous buck regulators (supporting 5A, 3.5A, 2x1.5A, 1A, 0.6A), with settable V_{OUT}
- 3 LDOs (supporting 2x300mA, 50mA), with bypass mode, and settable V_{OUT}
- Dedicated VTTREF for DDR memory
- Auto PFM/PWM, FPWM and ultrasonic modes, with selectable PWM f_{SW}
- Built-in 32kHz crystal oscillator (with bypass), RTC, and coin cell/supercapacitor battery charger
- DVS and sleep modes
- Internally compensated
- Spread spectrum
- I²C serial interface (up to 1MHz)
- Pb-free (RoHS compliant)

Applications

- MCU/MPU/SoC consumer and industrial power
- FPGA system power
- Building/factory automation system power

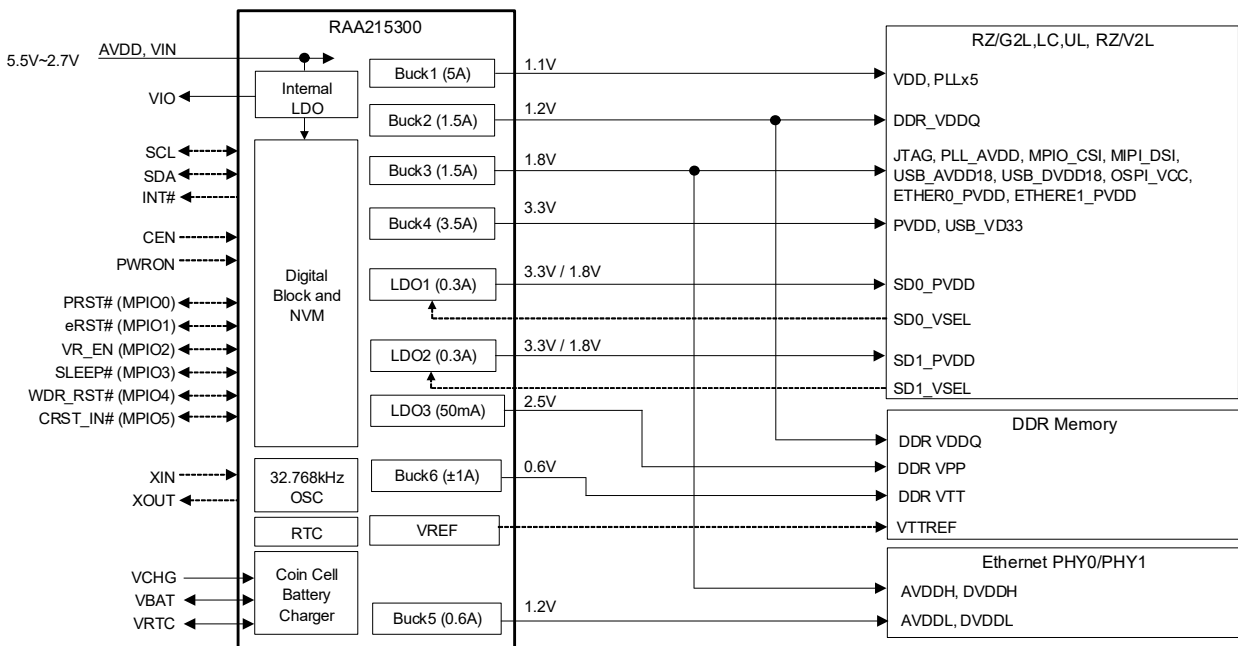

Figure 1. Typical Application Diagram - MPU Power

IMPORTANT NOTICE AND DISCLAIMER

RENESAS ELECTRONICS CORPORATION AND ITS SUBSIDIARIES (“RENESAS”) PROVIDES TECHNICAL SPECIFICATIONS AND RELIABILITY DATA (INCLUDING DATASHEETS), DESIGN RESOURCES (INCLUDING REFERENCE DESIGNS), APPLICATION OR OTHER DESIGN ADVICE, WEB TOOLS, SAFETY INFORMATION, AND OTHER RESOURCES “AS IS” AND WITH ALL FAULTS, AND DISCLAIMS ALL WARRANTIES, EXPRESS OR IMPLIED, INCLUDING, WITHOUT LIMITATION, ANY IMPLIED WARRANTIES OF MERCHANTABILITY, FITNESS FOR A PARTICULAR PURPOSE, OR NON-INFRINGEMENT OF THIRD PARTY INTELLECTUAL PROPERTY RIGHTS.

These resources are intended for developers skilled in the art designing with Renesas products. You are solely responsible for (1) selecting the appropriate products for your application, (2) designing, validating, and testing your application, and (3) ensuring your application meets applicable standards, and any other safety, security, or other requirements. These resources are subject to change without notice. Renesas grants you permission to use these resources only for development of an application that uses Renesas products. Other reproduction or use of these resources is strictly prohibited. No license is granted to any other Renesas intellectual property or to any third party intellectual property. Renesas disclaims responsibility for, and you will fully indemnify Renesas and its representatives against, any claims, damages, costs, losses, or liabilities arising out of your use of these resources. Renesas' products are provided only subject to Renesas' Terms and Conditions of Sale or other applicable terms agreed to in writing. No use of any Renesas resources expands or otherwise alters any applicable warranties or warranty disclaimers for these products.

(Disclaimer Rev.1.0 Mar 2020)

Corporate Headquarters

TOYOSU FORESIA, 3-2-24 Toyosu,
Koto-ku, Tokyo 135-0061, Japan
www.renesas.com

Contact Information

For further information on a product, technology, the most up-to-date version of a document, or your nearest sales office, please visit:
www.renesas.com/contact/

Trademarks

Renesas and the Renesas logo are trademarks of Renesas Electronics Corporation. All trademarks and registered trademarks are the property of their respective owners.