

# RBN40H125S1FPQ-A0

1250V - 40A - IGBT  
Power Switching

R07DS1380EJ0141  
Rev.1.41  
Oct.14.2021

## Features

- Trench gate and thin wafer technology (G8H series)
- Built in fast recovery diode in one package
- Low collector to emitter saturation voltage  
 $V_{CE(sat)} = 1.8\text{ V typ. (at } I_C = 40\text{ A, } V_{GE} = 15\text{ V, } T_a = 25^\circ\text{C)}$
- Quality grade: Standard
- High speed switching
- Short circuit withstands time (10  $\mu\text{s min.}$ )
- Applications: UPS, Welding, photovoltaic inverters, Power converter system

## Key Performance

Type	$V_{CES}$	$I_C$	$V_{CE(sat)}, T_C=25^\circ\text{C}$	$I_F$	tsc	$T_j$
RBN40H125S1FPQ-A0	1250 V	40 A	1.8 V	25 A	10 $\mu\text{s}$	175 $^\circ\text{C}$

## Outline

RENESAS Package code: PRSS0003ZH-A  
(Package name: TO-247A)

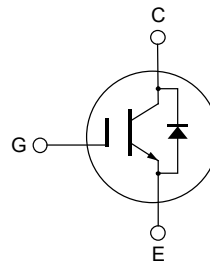
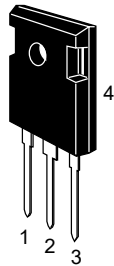

1. Gate
2. Collector
3. Emitter
4. Collector

## Absolute Maximum Ratings

(T<sub>c</sub> = 25°C)

Item	Symbol	Ratings	Unit
Collector to emitter voltage	V <sub>CES</sub>	1250	V
Gate to emitter voltage	V <sub>GES</sub>	±30	V
Collector current	T <sub>c</sub> = 25 °C	I <sub>C</sub>	80
	T <sub>c</sub> = 100 °C	I <sub>C</sub>	40
Collector peak current	I <sub>C(peak)</sub> Notes1	160	A
Diode forward current	T <sub>c</sub> = 25 °C	I <sub>F</sub>	50
	T <sub>c</sub> = 100 °C	I <sub>F</sub>	25
Diode forward peak current	I <sub>F(peak)</sub> Notes1	160	A
Collector power dissipation	P <sub>C</sub> Notes2	319	W
Junction temperature	T <sub>J</sub> Notes2	175	°C
Storage temperature	T <sub>stg</sub>	-55 to +150	°C

Note: Continuous heavy condition (e.g. high temperature/voltage/current or high variation of temperature) may affect a reliability even if it is within the absolute maximum ratings. Please consider derating condition for appropriate reliability in reference Renesas Semiconductor Reliability Handbook (Recommendation for Handling and Usage of Semiconductor Devices) and individual reliability data.

Notes: 1. PW ≤ 10 μs, duty cycle ≤ 1%

2. Please use this device in the thermal conditions which the junction temperature does not exceed 175 °C.  
Renesas IGBT Application Note is disclosed about reliability test and application condition up to 175 °C.

## Thermal Resistance Characteristics

(T<sub>c</sub> = 25°C)

Item	Symbol	Max. Value Notes3	Unit
Junction to case thermal resistance (IGBT)	R <sub>th(j-c)</sub>	0.47	°C/W
Junction to case thermal resistance (Diode)	R <sub>th(j-c)</sub>	1.61	°C/W

Notes: 3. Designed target value on Renesas measurement condition. (Not tested)

## Electrical Characteristics

(T<sub>c</sub> = 25°C)

Item	Symbol	Min	Typ	Max	Unit	Test Conditions
Collector to emitter leakage current	I <sub>CES</sub>	—	—	200	μA	V <sub>CE</sub> = 1250 V, V <sub>GE</sub> = 0 V
Gate to emitter leakage current	I <sub>GES</sub>	—	—	±1	μA	V <sub>GE</sub> = ±30 V, V <sub>CE</sub> = 0 V
Gate to emitter threshold voltage	V <sub>GE(th)</sub>	5.3	—	7.1	V	V <sub>CE</sub> = 10 V, I <sub>C</sub> = 1.3 mA
Collector to emitter saturation voltage	V <sub>CE(sat)</sub>	—	1.8	2.34	V	I <sub>C</sub> = 40 A, V <sub>GE</sub> = 15V <sup>Notes4</sup>
Input capacitance	C <sub>ies</sub>	—	2330	—	pF	V <sub>CE</sub> = 25 V V <sub>GE</sub> = 0 V f = 1 MHz
Output capacitance	C <sub>oes</sub>	—	120	—	pF	
Reverse transfer capacitance	C <sub>res</sub>	—	18	—	pF	
Total gate charge	Q <sub>g</sub>	—	85	—	nC	V <sub>GE</sub> = 15 V V <sub>CE</sub> = 600 V I <sub>C</sub> = 40 A
Gate to emitter charge	Q <sub>ge</sub>	—	25	—	nC	
Gate to collector charge	Q <sub>gc</sub>	—	44	—	nC	
Turn-on delay time	t <sub>d(on)</sub>	—	25	—	Ns	V <sub>CC</sub> = 600 V V <sub>GE</sub> = 15 V/-15 V I <sub>C</sub> = 40 A R <sub>g</sub> = 10 Ω T <sub>c</sub> = 25 °C Inductive load <sup>Notes5</sup>
Rise time	t <sub>r</sub>	—	11	—	ns	
Turn-off delay time	t <sub>d(off)</sub>	—	124	—	ns	
Fall time	t <sub>f</sub>	—	67	—	ns	
Turn-on loss energy	E <sub>on</sub>	—	2.0	—	mJ	
Turn-off loss energy	E <sub>off</sub>	—	1.4	—	mJ	
Total switching energy	E <sub>total</sub>	—	3.4	—	mJ	
Turn-on delay time	t <sub>d(on)</sub>	—	26	—	Ns	
Rise time	t <sub>r</sub>	—	13	—	ns	
Turn-off delay time	t <sub>d(off)</sub>	—	152	—	ns	
Fall time	t <sub>f</sub>	—	106	—	ns	
Turn-on loss energy	E <sub>on</sub>	—	3.3	—	mJ	
Turn-off loss energy	E <sub>off</sub>	—	2.5	—	mJ	
Total switching energy	E <sub>total</sub>	—	5.8	—	mJ	
Short circuit withstand time <sup>Notes6</sup>	t <sub>sc</sub>	10	—	—	μs	V <sub>CC</sub> ≤ 720 V, V <sub>GE</sub> = 15 V T <sub>c</sub> ≤ 150 °C

Diode forward voltage	V <sub>F</sub>	—	2.8	3.64	V	I <sub>F</sub> = 25 A <sup>Notes4</sup>
Diode reverse recovery time	t <sub>rr</sub>	—	156	—	ns	I <sub>F</sub> = 25 A, dI <sub>F</sub> /dt = 300 A/μs
Diode reverse recovery charge	Q <sub>rr</sub>	—	0.92	—	μC	
Diode peak reverse recovery current	I <sub>rr</sub>	—	10	—	A	

Notes: 4. Pulse test

5. Switching time test circuit and waveform are shown below.

6. Designed target value on Renesas measurement condition. (Not tested)

### Main Characteristics

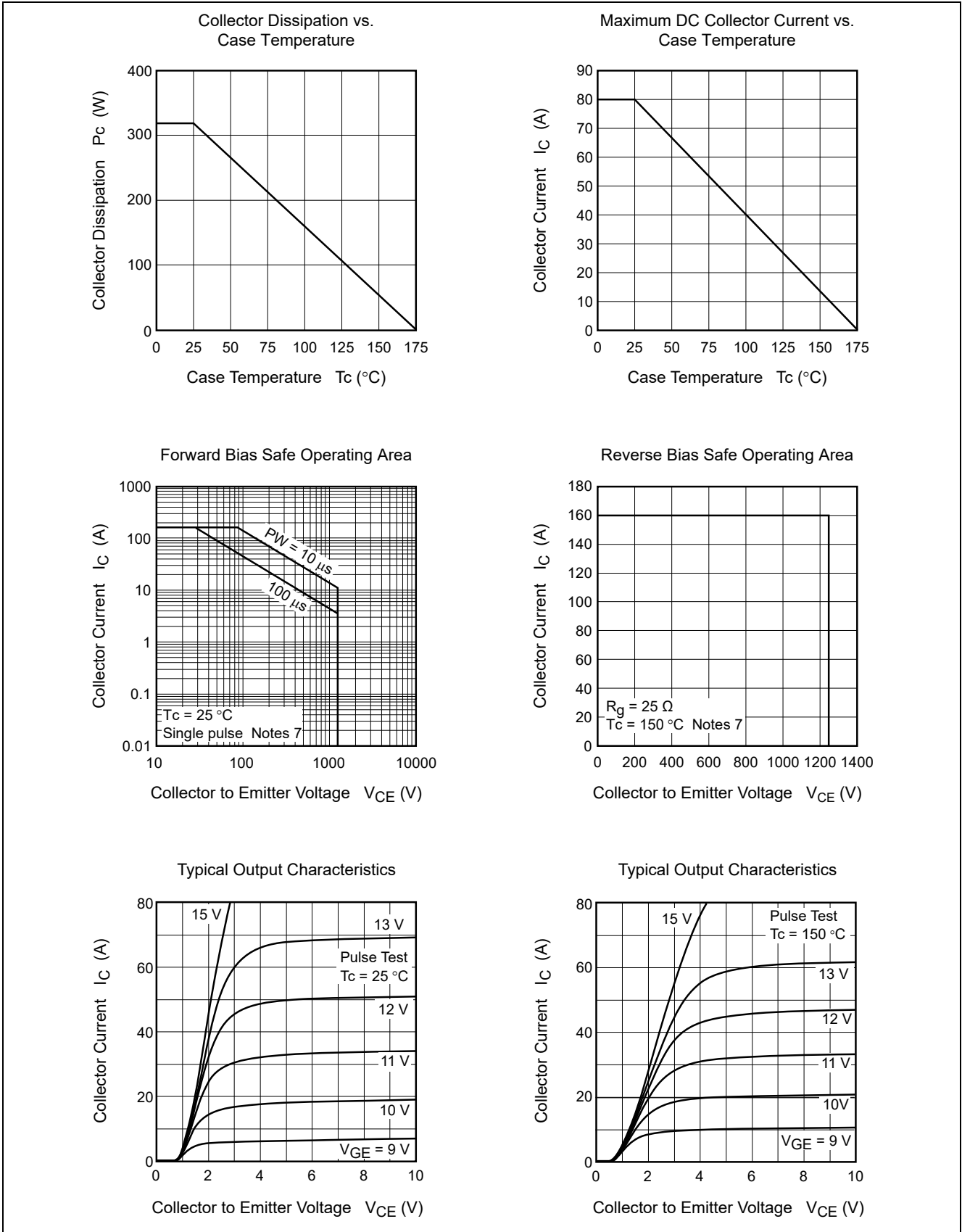

Notes: 7. Designed target value on Renesas measurement condition. (Not tested)

Renesas recommends that operating conditions are designed according to a document "Power MOS FET · IGBT Attention of Handling Semiconductor Devices".

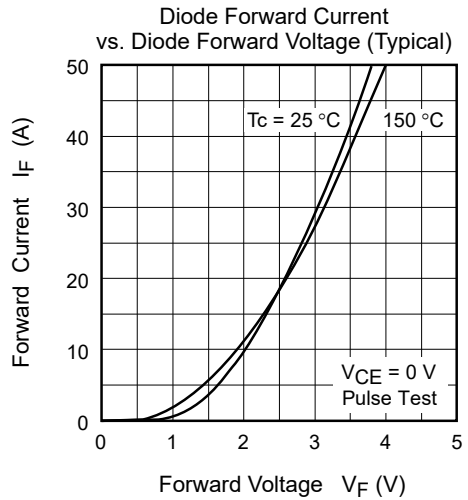
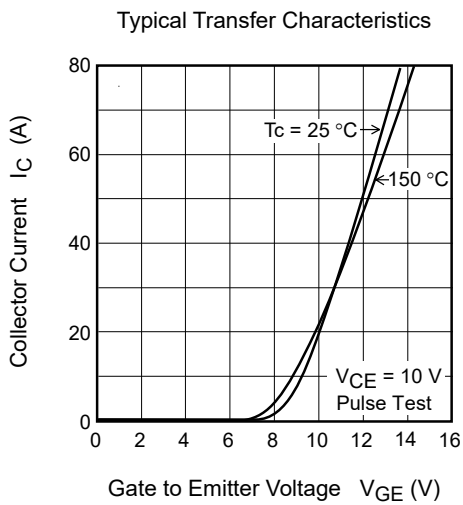
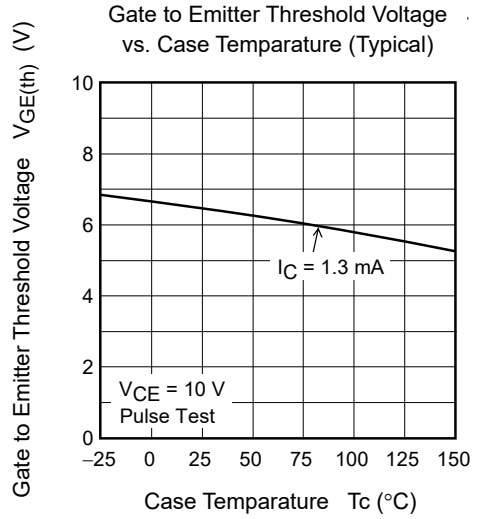
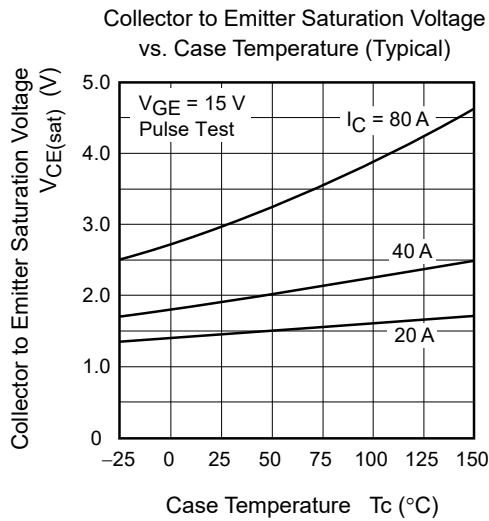
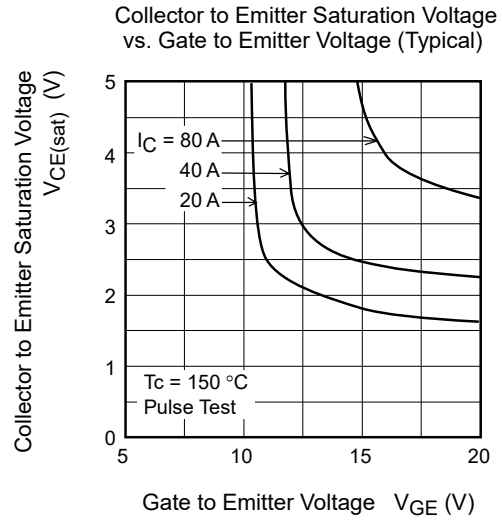
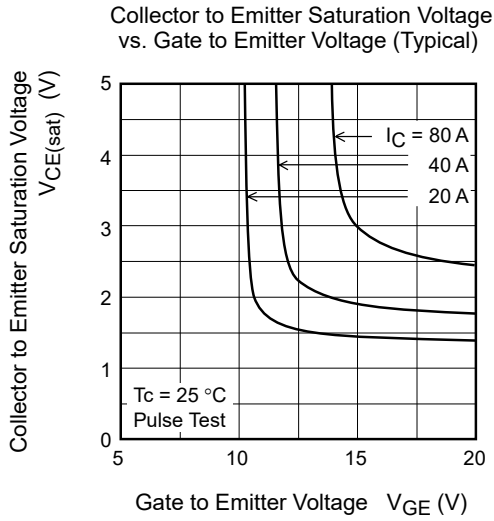

Switching Characteristics (Typical) (1)

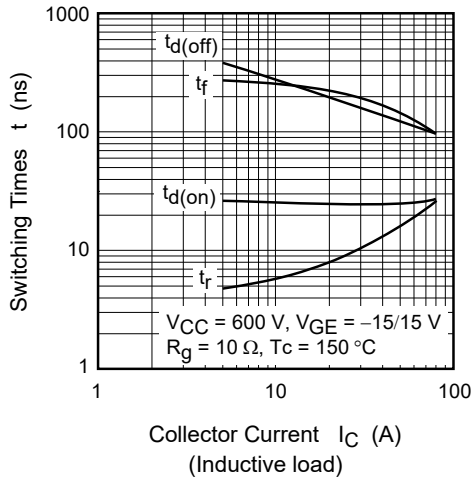

Switching Characteristics (Typical) (2)

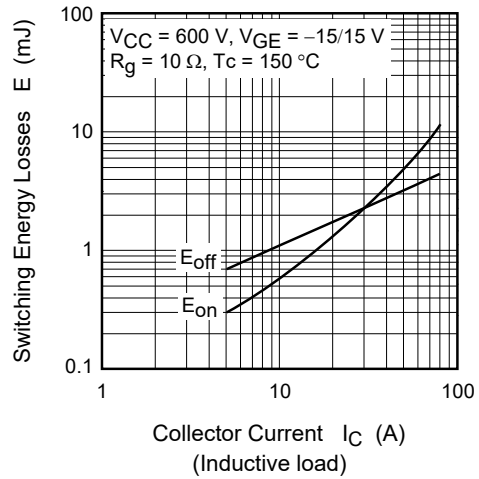

Switching Characteristics (Typical) (3)

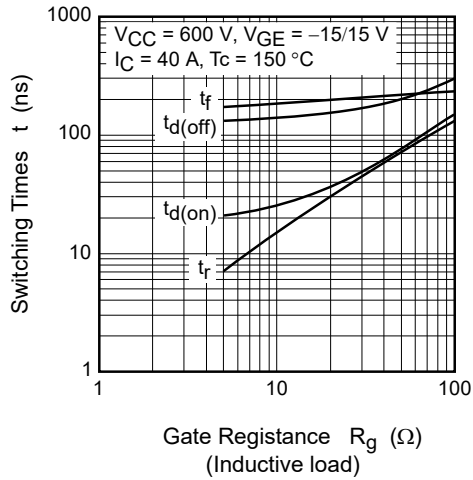

Switching Characteristics (Typical) (4)

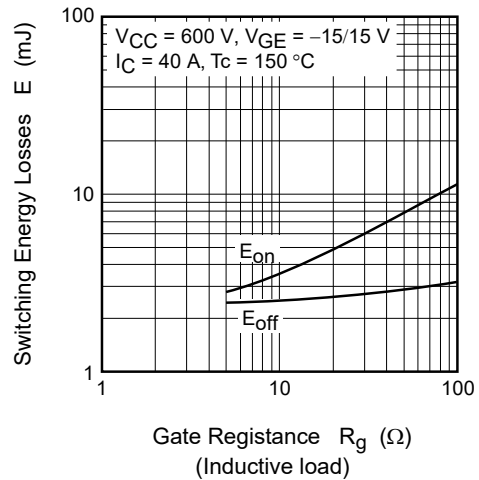

Switching Characteristics (Typical) (5)

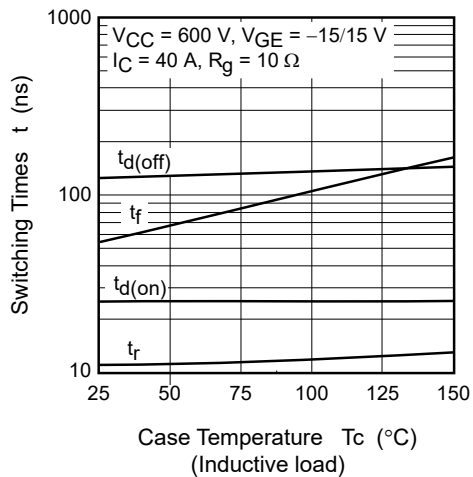

Switching Characteristics (Typical) (6)

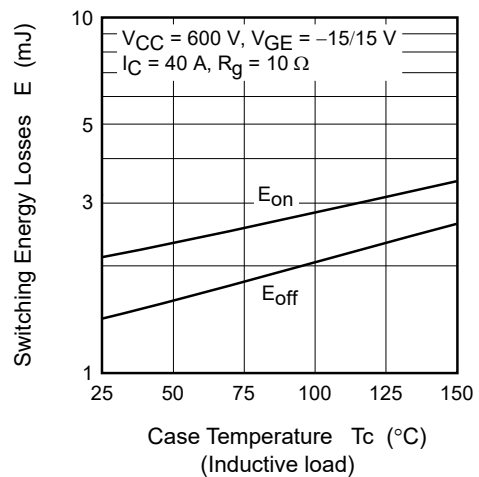

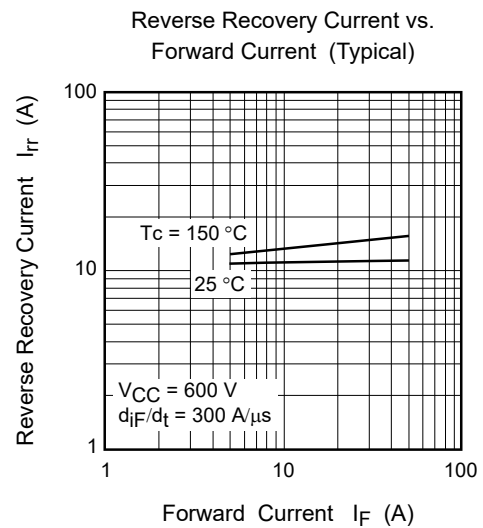
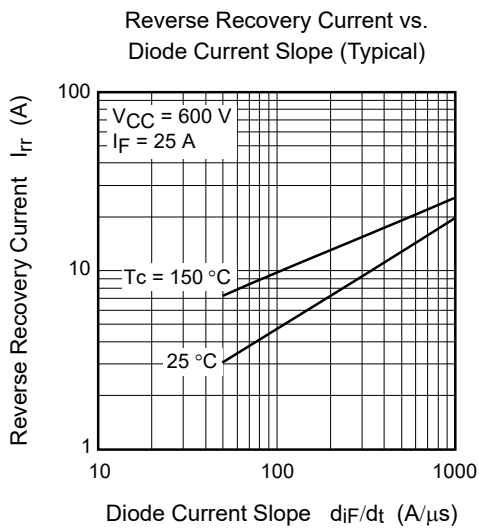
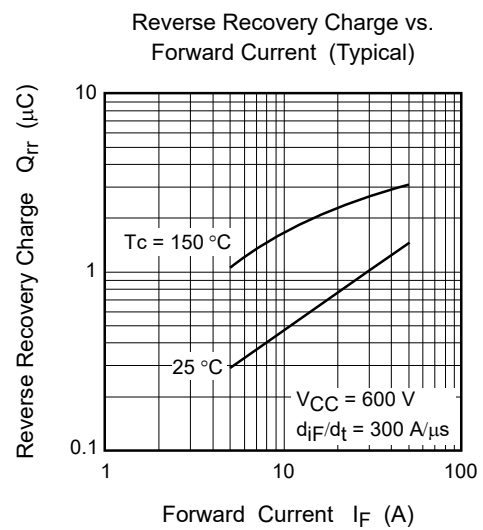
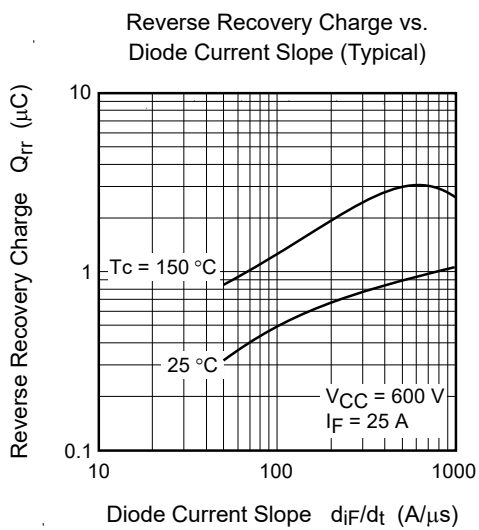
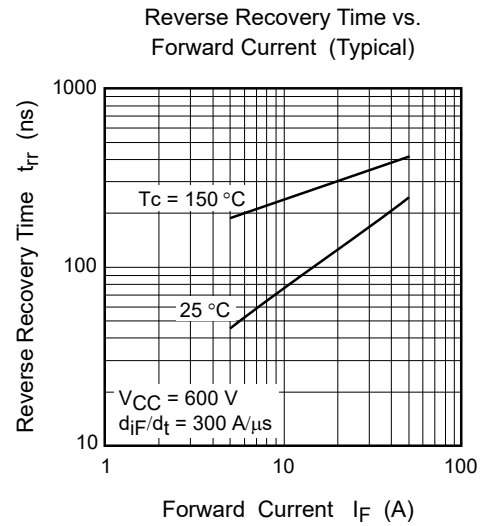
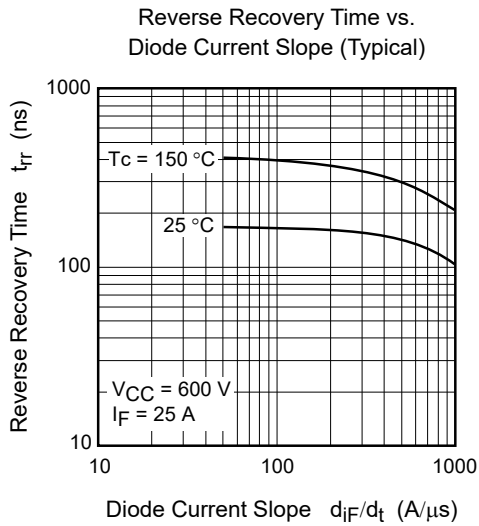

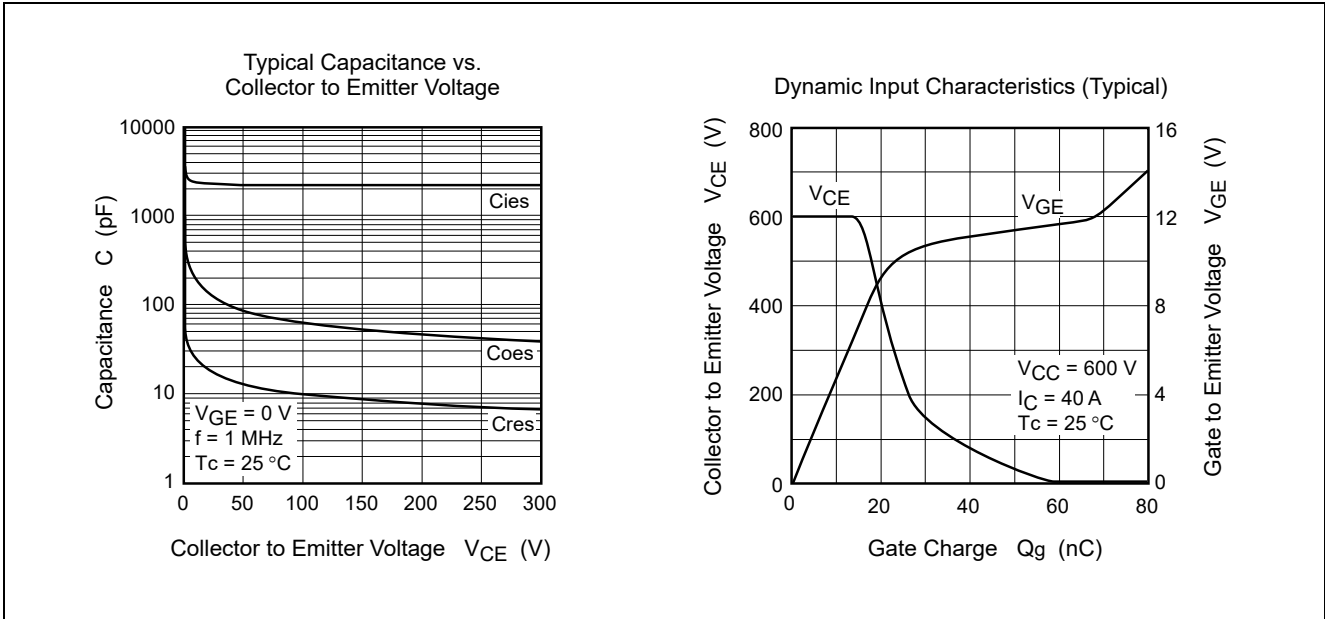



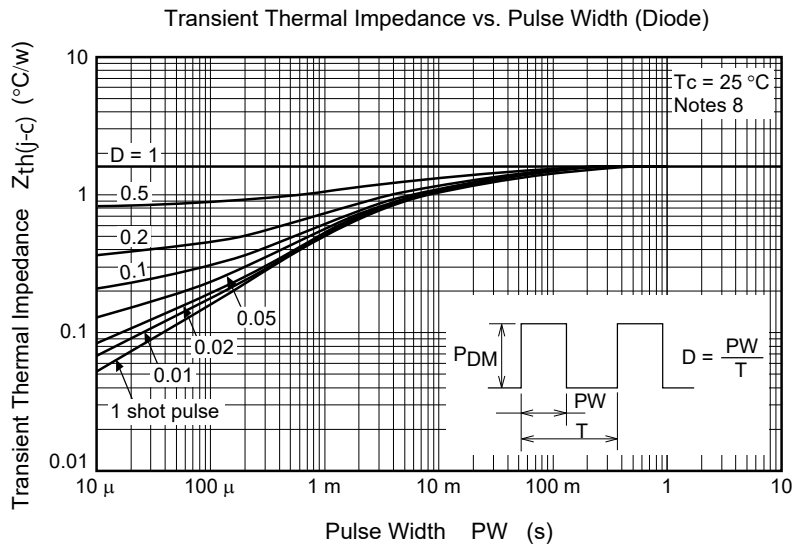
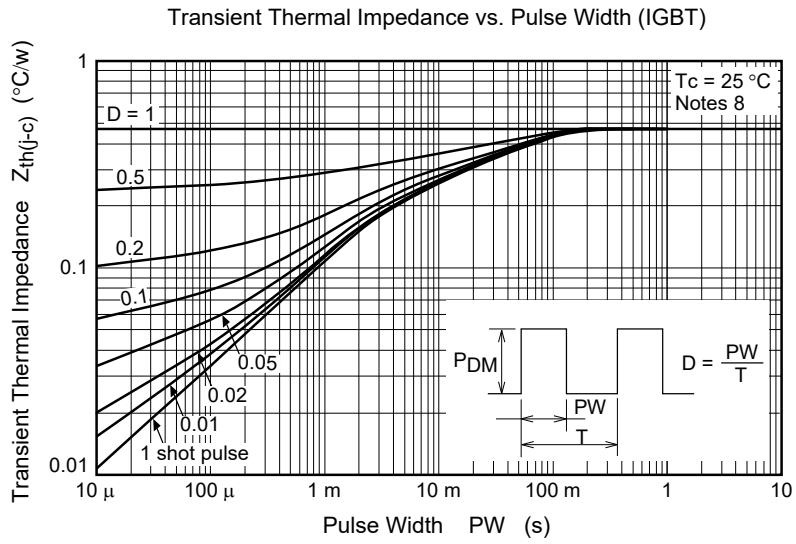

Notes: 8. Designed target value on Renesas measurement condition. (Not tested)

Switching Time Test Circuit

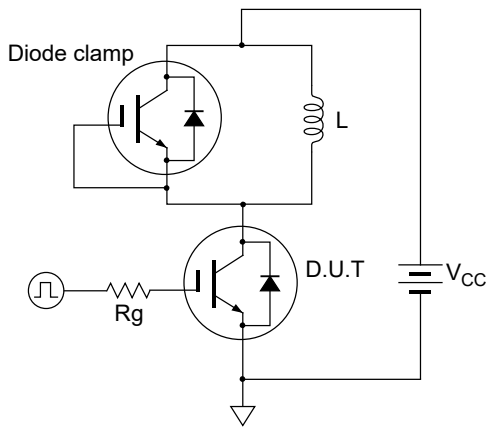

Waveform

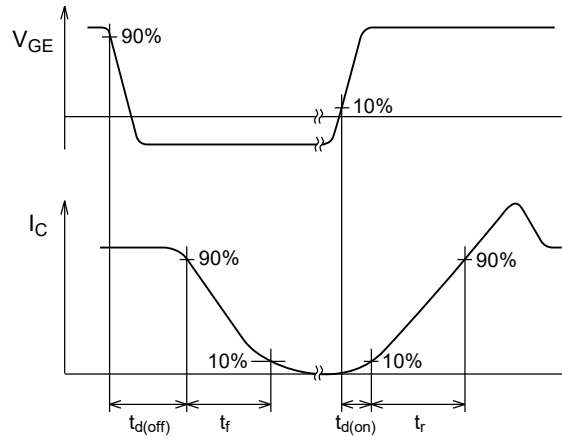

Diode Reverse Recovery Time Test Circuit

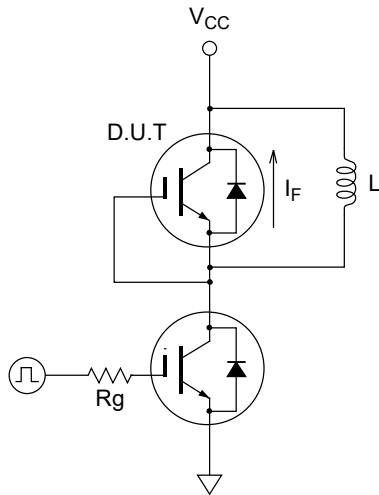

Waveform

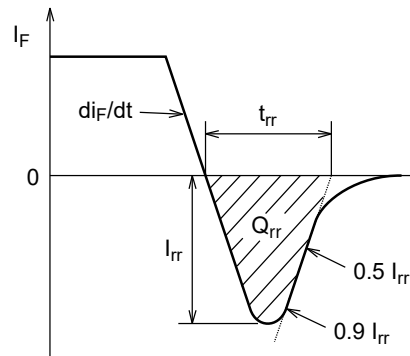

## Package Dimensions

JEDEC Package Code	RENESAS Code	Previous Code	MASS (Typ) [g]
TO-247AD	PRSS0003ZH-A	—	6.14

Unit: mm

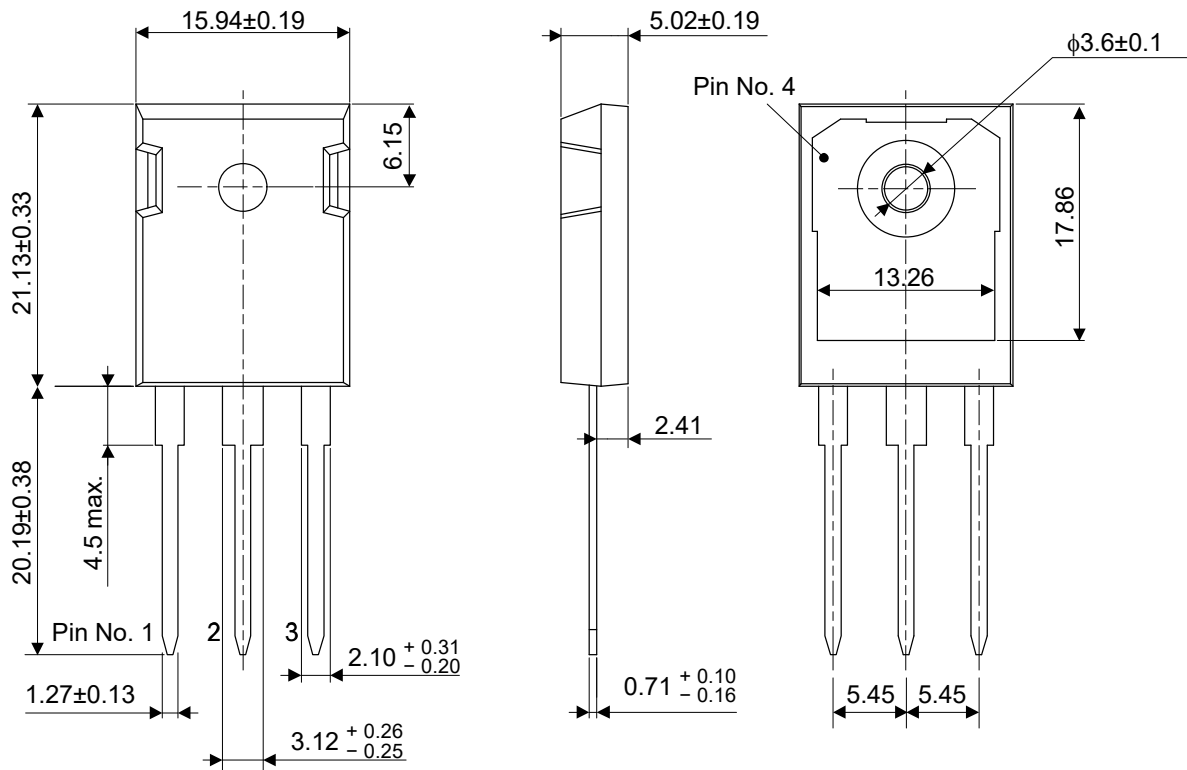

© 2019 Renesas Electronics Corporation. All rights reserved.

## Ordering Information

Orderable Part Number	Quantity	Shipping Container
RBN40H125S1FPQ-A0#CB0	240 pcs	Box (Tube)