



# RCB-F9T-1

## Timing board

### Data sheet



### Abstract

This data sheet describes the RCB-F9T-1 timing board, which provides an industry standard connector access to the ZED-F9T-10B timing module and includes an SMB antenna connector and 8-pin connector for easy connectivity.

# Document information

<b>Title</b>	<b>RCB-F9T-1</b>	
<b>Subtitle</b>	Timing board	
<b>Document type</b>	Data sheet	
<b>Document number</b>	UBX-21004244	
<b>Revision and date</b>	R03	30-Aug-2023
<b>Disclosure restriction</b>	C1-Public	

<b>Product status</b>	<b>Corresponding content status</b>	
<b>Functional Sample</b>	Draft	For functional testing. Revised and supplementary data will be published later.
<b>In development / prototype</b>	Objective specification	Target values. Revised and supplementary data will be published later.
<b>Engineering sample</b>	Advance information	Data based on early testing. Revised and supplementary data will be published later.
<b>Initial production</b>	Early production information	Data from product verification. Revised and supplementary data may be published later.
<b>Mass production / End of life</b>	Production information	Document contains the final product specification.

This document applies to the following products:

<b>Product name</b>	<b>Type number</b>	<b>FW version</b>	<b>IN/PCN reference</b>	<b>Product status</b>
RCB-F9T	RCB-F9T-1-01	TIM 2.20	-	Mass production

u-blox or third parties may hold intellectual property rights in the products, names, logos and designs included in this document. Copying, reproduction, or modification of this document or any part thereof is only permitted with the express written permission of u-blox. Disclosure to third parties is permitted for clearly public documents only.

The information contained herein is provided "as is" and u-blox assumes no liability for its use. No warranty, either express or implied, is given, including but not limited to, with respect to the accuracy, correctness, reliability and fitness for a particular purpose of the information. This document may be revised by u-blox at any time without notice. For the most recent documents, visit [www.u-blox.com](http://www.u-blox.com).

Copyright © 2023, u-blox AG.

# Contents

<b>1 Functional description.....</b>	<b>4</b>
1.1 Overview.....	4
1.2 Performance.....	4
1.3 Supported GNSS constellations.....	5
1.4 Supported GNSS augmentation systems.....	5
1.4.1 Quasi-Zenith Satellite System (QZSS).....	5
1.4.2 Satellite-based augmentation system (SBAS).....	5
1.4.3 Differential timing mode.....	6
1.5 Broadcast navigation data and satellite signal measurements.....	6
1.5.1 Carrier-phase measurements.....	6
1.6 Supported protocols.....	6
<b>2 System description.....</b>	<b>7</b>
2.1 Block diagram.....	7
<b>3 Pin definition.....</b>	<b>8</b>
3.1 Pin assignment.....	8
<b>4 Electrical specification.....</b>	<b>9</b>
4.1 Absolute maximum ratings.....	9
4.2 Operating conditions.....	9
4.3 Indicative power requirements.....	10
<b>5 Communications interfaces.....</b>	<b>11</b>
5.1 UART.....	11
5.2 Default interface settings.....	11
<b>6 Mechanical specification.....</b>	<b>12</b>
<b>7 Reliability tests and approvals.....</b>	<b>13</b>
7.1 Approvals.....	13
<b>8 Labeling and ordering information.....</b>	<b>14</b>
8.1 Product labeling.....	14
8.2 Explanation of product codes.....	14
8.3 Ordering codes.....	14
<b>Related documents.....</b>	<b>15</b>
<b>Revision history.....</b>	<b>16</b>

# 1 Functional description

## 1.1 Overview

The RCB-F9T-1 timing board enables multi-band GNSS timing in a compact form factor using the ZED-F9T-10B, the u-blox F9 high accuracy timing module. The ZED-F9T-10B module provides nanosecond-level timing accuracy in both standalone and differential timing modes.

In addition to the ZED-F9T-10B module, the RCB-F9T-1 timing board contains an SMB antenna connector and 5 V power supply circuitry for an external active multi-band GNSS antenna. The 8-pin, 2.0 mm pitch pin-header provides powering of the board, UART communications, and two independently configurable time pulse signals.

## 1.2 Performance

Parameter	Specification	
Receiver type	Multi-band GNSS receiver for timing applications	
Accuracy of time pulse signal <sup>1</sup>	Absolute timing mode	5 ns
	Differential timing mode <sup>2</sup>	2.5 ns
Frequency of time pulse signal	0.25 Hz to 25 MHz (configurable)	
Time pulse jitter	±4 ns	
Operational limits <sup>3</sup>	Dynamics	≤ 4 g
	Altitude	80,000 m
	Velocity	500 m/s
Velocity accuracy <sup>4</sup>	0.05 m/s	
Dynamic heading accuracy <sup>4</sup>	0.3 deg	

**Table 1: RCB-F9T-1 specifications**

GNSS		GPS+GLO+GAL+BDS	GPS+BDS+GAL	GPS+GAL	GPS+GLO	GPS+BDS	GPS
Acquisition <sup>5</sup>	Cold start	24 s	25 s	29 s	26 s	28 s	29 s
	Hot start	2 s	2 s	2 s	2 s	2 s	2 s
	Aided start <sup>6</sup>	2 s	2 s	2 s	2 s	2 s	2 s
Max navigation update rate <sup>7</sup>		8 Hz	10 Hz	15 Hz	15 Hz	12 Hz	20 Hz

**Table 2: RCB-F9T-1 performance in different GNSS modes**

- 1 1-sigma, fixed position mode, depends on temperature, atmospheric conditions, baseline length, GNSS antenna, multipath conditions, satellite visibility and geometry
- 2 Demonstrated with 20 km baseline
- 3 Assuming Airborne 4 g platform
- 4 50% at 30 m/s for dynamic operation
- 5 Commanded starts. All satellites at -130 dBm. Measured at room temperature. Dual band operation
- 6 Dependent on the speed and latency of the aiding data connection, commanded starts
- 7 95% In PVT navigation mode, assumes secondary navigation output disabled (default)

GNSS		GPS+GLO+GAL+BDS	GPS+BDS+GAL	GPS+GAL	GPS+GLO	GPS+BDS	GPS
Horizontal pos. accuracy	Standalone <sup>8</sup>	1.5 m CEP	1.5 m CEP	1.5 m CEP	1.5 m CEP	1.5 m CEP	1.5 m CEP

**Table 3: RCB-F9T-1 position accuracy in different GNSS modes**

In order to achieve the best absolute timing accuracy, measure the propagation delay of the entire signal path from the antenna to the receiver's time pulse output, and then compensate for this delay using the CFG-TP configuration items.

## 1.3 Supported GNSS constellations

The RCB-F9T-1 timing board is a concurrent GNSS receiver that can receive and track multiple GNSS systems. Thanks to the multi-band RF front-end architecture, all four major GNSS constellations (GPS, Galileo, GLONASS and BeiDou) as well as NavIC, SBAS and QZSS satellites can be received concurrently. If low power consumption is a key factor, then the receiver can be configured for a subset of GNSS constellations.

The RCB-F9T-1 can receive the NavIC L5 satellite signals that share the same frequency with GPS L5 signals and can be configured to work on its own or in parallel with the other GNSS constellations.

The QZSS system shares the same frequency bands with GPS and can only be processed in conjunction with GPS.

The RCB-F9T-1 supports the GNSS and their signals as shown in [Table 4](#).

GPS / QZSS	GLONASS	Galileo	BeiDou	NavIC
L1C/A (1575.420 MHz)	L1OF (1602 MHz + k*562.5 kHz, k = -7,...,6)	E1-B/C (1575.420 MHz)	B1I (1561.098 MHz) B1C (1575.420 MHz) <sup>9</sup>	-
L5 (1176.450 MHz)	-	E5a (1176.450 MHz)	B2a (1176.450 MHz)	SPS-L5 (1176.450 MHz)

**Table 4: Supported GNSS signals on RCB-F9T-1**

The RCB-F9T-1 can use the u-blox AssistNow™ Online service which provides GNSS assistance information.

## 1.4 Supported GNSS augmentation systems

### 1.4.1 Quasi-Zenith Satellite System (QZSS)

The Quasi-Zenith Satellite System (QZSS) is a regional navigation satellite system that provides positioning services for the Pacific region covering Japan and Australia. The RCB-F9T-1 is able to receive and track QZSS L1 C/A and L5 signals concurrently with GPS signals, resulting in better availability especially under challenging signal conditions, e.g. in urban canyons.



QZSS can be enabled only if GPS operation is also configured.

### 1.4.2 Satellite-based augmentation system (SBAS)

The RCB-F9T-1 supports SBAS (including WAAS in the US, EGNOS in Europe, L1Sb(QZSS SBAS) in Japan and GAGAN in India) to deliver improved location accuracy within the regions covered. However, the additional inter-standard time calibration step used during SBAS reception results in degraded time accuracy overall.

<sup>8</sup> Depends on atmospheric conditions, GNSS antenna, multipath conditions, satellite visibility, and geometry

<sup>9</sup> BeiDou B1I and B1C signals are not to be enabled concurrently

 SBAS reception is disabled by default in RCB-F9T-1.

### 1.4.3 Differential timing mode

To improve timing accuracy locally, the RCB-F9T-1 can be used in differential timing mode, in which correction data is sent to neighboring RCB-F9T-1 timing receivers via a communication network.

In differential timing mode the RCB-F9T-1 can operate either as a reference station generating the following RTCM 3.3 messages, or as a corrected station using the following RTCM 3.3 messages:

Message type	Description
RTCM 1005	Stationary RTK reference station ARP
RTCM 1077	GPS MSM7
RTCM 1087	GLONASS MSM7
RTCM 1097	Galileo MSM7
RTCM 1127	BeiDou MSM7
RTCM 1230	GLONASS code-phase biases
RTCM 4072.1	Additional reference station information (u-blox proprietary RTCM Message)

**Table 5: Supported RTCM 3.3 messages**

## 1.5 Broadcast navigation data and satellite signal measurements

The RCB-F9T-1 can output all the GNSS broadcast data upon reception from tracked satellites. This includes all the supported GNSS signals as well as the QZSS and SBAS augmentation services. The UBX-RXM-SFRBX message provides this information, see the Interface description [2] for the UBX-RXM-SFRBX message specification. The receiver can provide satellite signal information in a form compatible with the Radio Resource LCS Protocol (RRLP) [4].

### 1.5.1 Carrier-phase measurements

The RCB-F9T-1 modules provide raw carrier-phase data for all supported signals, along with pseudorange, Doppler and measurement quality information. The data contained in the UBX-RXM-RAWX message follows the conventions of a multi-GNSS RINEX 3 observation file. For the UBX-RXM-RAWX message specification, see Interface description [2].

 Raw measurement data are available once the receiver has established data bit synchronization and time-of-week.

## 1.6 Supported protocols

The RCB-F9T-1 supports the following protocols:

Protocol	Type
UBX	Input/output, binary, u-blox proprietary
NMEA 4.11 (default), 4.10, 4.0, 2.3, and 2.1	Input/output, ASCII
RTCM 3.3	Input/output, binary

**Table 6: Supported protocols**

For specification of the protocols, see the Interface description [2].

## 2 System description

### 2.1 Block diagram

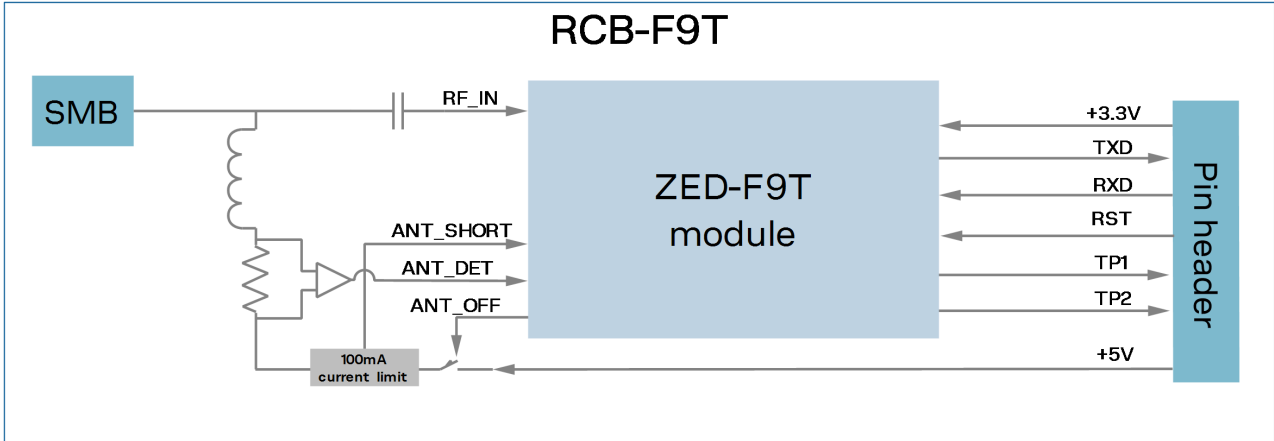
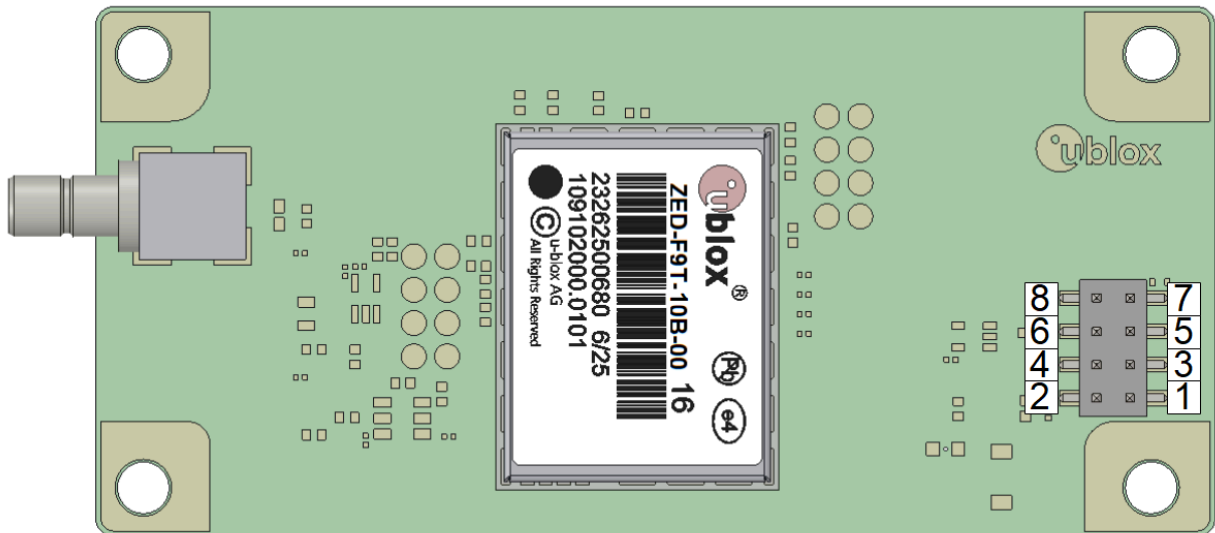

Figure 1: RCB-F9T-1 block diagram

## 3 Pin definition

### 3.1 Pin assignment

The pin assignment of the RCB-F9T-1 module is shown in [Figure 2](#). The defined configuration of the PIOs is listed in [Table 7](#).



**Figure 2: RCB-F9T-1 pin assignment**

Pin no.	Name	I/O	Description
1	VCC_ANT	I	Antenna power supply. 5.0 V max 100 mA
2	VCC	I	Operating voltage, 3.3 V
3	TXD	O	UART TXD, LVCMOS
4	RST	I	Hardware reset
5	RXD	I	UART RXD, LVCMOS
6	TP1	O	Time pulse1, LVCMOS
7	TP2	O	Time pulse2, LVCMOS
8	GND	-	Ground

**Table 7: RCB-F9T-1 pin assignment**



See [Figure 1](#) for a detailed view of the board measurements.



The labelling of the u-blox module in [Figure 2](#) is for the illustration purpose only.



## 4 Electrical specification

**CAUTION** Operating the device above one or more of the limiting values may cause permanent damage to the device. The values provided in this chapter are stress ratings. Extended exposure to the values outside the limits may effect the device reliability.

Where application information is given, it is advisory only and does not form part of the specification.

### 4.1 Absolute maximum ratings

Parameter	Symbol	Condition	Min	Max	Units
Power supply voltage	VCC		-0.5	3.6	V
Antenna power supply voltage	VCC_ANT		-0.5	5.5	V
Input pin voltage	Vin	VCC ≤ 3.1	-0.5	VCC + 0.5	V
		VCC > 3.1 V	-0.5	3.6	V
Input power at ANT connector	Prfin	source impedance = 50 Ω, continuous wave		10	dBm
Storage temperature	Tstg		-40	+85	°C

**Table 8: Absolute maximum ratings**

**CAUTION** Risk of equipment damage. This product is not protected against overvoltage or reversed voltages. Use appropriate protection diodes to avoid voltage spikes exceeding the specified boundaries damaging the equipment.

### 4.2 Operating conditions

The values for the following operating conditions have been specified at 25°C ambient temperature. Extreme operating temperatures can significantly impact the specified values. If an application operates near the min or max temperature limits, ensure the specified values are not exceeded.

Parameter	Symbol	Min	Typical	Max	Units	Condition
Power supply voltage	VCC	2.7	3.0	3.6	V	
Power supply current	ICC		100		mA	3.3 V
External antenna power supply voltage	VCC_ANT	4.5	5.0	5.5	V	
External antenna current consumption <sup>10</sup>	ICC_ANT	18		100	mA	
Input pin voltage range	Vin	0		VCC	V	
Digital IO pin low level input voltage	Vil			0.4	V	
Digital IO pin high level input voltage	Vih	0.8 * VCC			V	
Digital IO pin low level output voltage TIMEPULSE	Vol			0.4	V	Iol = 2 mA Iol = 4 mA
Digital IO pin high level output voltage TIMEPULSE	Voh	VCC - 0.4			V	Ioh = 2 mA Ioh = 4 mA
DC current through any digital I/O pin (except supplies)	Ipin			5	mA	

<sup>10</sup> If antenna current consumption is less than specified Min value, then attached antenna will not be detected.

Parameter	Symbol	Min	Typical	Max	Units	Condition
Receiver chain noise figure <sup>11</sup>	NFtot		9.5		dB	
External gain (at RF_IN)	Ext_gain	17		50	dB	
Operating temperature	Topr	-40	+25	+85	°C	

**Table 9: Operating conditions**

 Operation beyond the specified operating conditions can affect the device reliability.

### 4.3 Indicative power requirements

**Table 10** provides examples of typical current requirements when using a cold start command. The given values are total system supply current for a possible application including RF and baseband sections.

 The actual power requirements vary depending on the FW version used, external circuitry, number of satellites tracked, signal strength, type and time of start, duration, and conditions of test.

Symbol	Parameter	Conditions	GPS+GLO +GAL+BDS	GPS	Unit
I <sub>PEAK</sub>	VCC peak current	Acquisition	130	120	mA
I <sub>VCC</sub> <sup>12</sup>	VCC current	Acquisition	90	75	mA
I <sub>VCC</sub> <sup>12</sup>	VCC current	Tracking	85	68	mA

**Table 10: Currents to calculate the indicative power requirements**

All values in **Table 10** are measured at 25 °C ambient temperature.

 VCC\_ANT current is depending on used active antenna current consumption. Maximum current is limited to 100 mA.

<sup>11</sup> Only valid for GPS

<sup>12</sup> Simulated signal

## 5 Communications interfaces

All the inputs have internal pull-up resistors in normal operation and can be left open if not used. All the PIOs are supplied by VCC, therefore all the voltage levels of the PIO pins are related to VCC supply voltage.

### 5.1 UART

The RCB-F9T-1 has one UART interface which supports configurable baud rates. See the integration manual [1].

Hardware flow control is not supported.

Symbol	Parameter	Min	Max	Unit
R <sub>u</sub>	Baud rate	9600	921600	bit/s

Table 11: RCB-F9T-1 UART specifications

### 5.2 Default interface settings

Interface	Settings
UART Output	115200 baud, 8 bits, no parity bit, 1 stop bit. NMEA <b>GGA, GLL, GSA, GSV, RMC, VTG, TXT</b> (and no UBX) messages are output by default.
UART Input	115200 baud, 8 bits, no parity bit, 1 stop bit. UBX, NMEA and RTCM 3.3 messages are enabled by default.

Table 12: Default configurations



Refer to the applicable interface description [2] for information about further settings.

By default the RCB-F9T-1 outputs NMEA messages that include satellite data for all GNSS bands being received. This results in a higher-than-before NMEA load output for each navigation period. Make sure the UART baud rate being used is sufficient for the selected navigation rate and the number of GNSS signals being received.

## 6 Mechanical specification

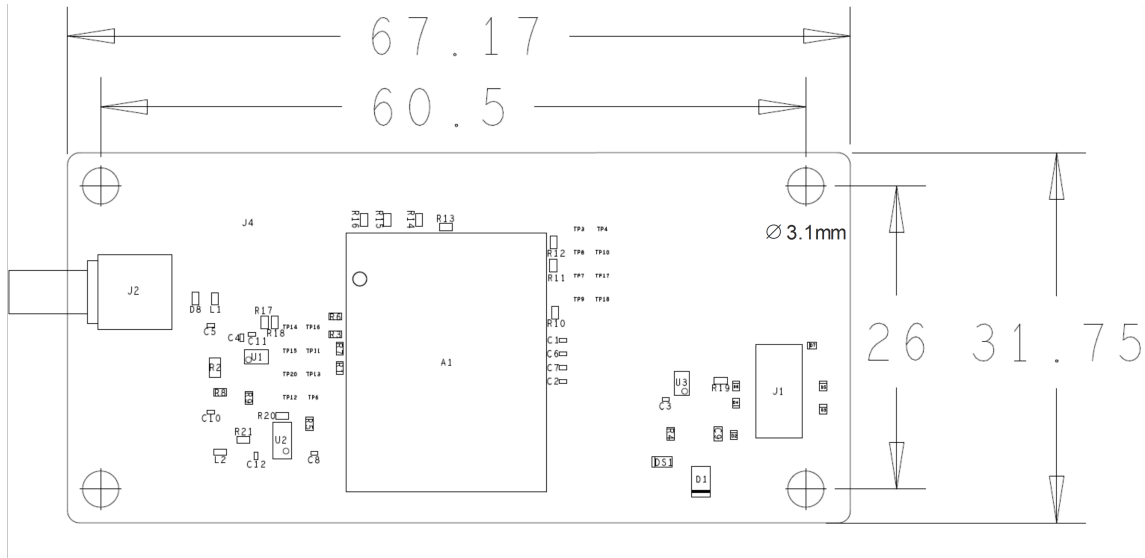

Figure 3: RCB-F9T-1 mechanical drawing



For accurate mounting and antenna connector alignment information, see the u-blox Integration manual [1] for a detailed PCB view.

## 7 Reliability tests and approvals

The ZED-F9T-10B modules are based on AEC-Q100 qualified GNSS chips.

Tests for product family qualifications comply with ISO 16750 "Road vehicles – environmental conditions and testing for electrical and electronic equipment", and appropriate standards.

### 7.1 Approvals

RCB-F9T-1 complies with the essential requirements and other relevant provisions of the Radio Equipment Directive (RED) 2014/53/EU.

RCB-F9T-1 complies with the Directive 2011/65/EU (EU RoHS 2) and its amendment Directive (EU) 2015/863 (EU RoHS 3).

The Declaration of Conformity (DoC) is available on the [u-blox website](#).

## 8 Labeling and ordering information

This section provides information about product labeling and ordering. For information about moisture sensitivity level (MSL), product handling and soldering see the Integration manual [1].

### 8.1 Product labeling

The labeling of the RCB-F9T-1 timing boards provides product information and revision information. For more information contact u-blox sales.

### 8.2 Explanation of product codes

Three product code formats are used in the RCB-F9T-1 labels. The **Product name** used in documentation such as this data sheet identifies all u-blox products, independent of packaging and quality grade. The **Ordering code** includes options and quality, while the **Type number** includes the hardware and firmware versions.

Table 13 below details these three formats.

Format	Structure	Product code
Product name	PPP-TGV	RCB-F9T
Ordering code	PPP-TGV-N	RCB-F9T-1
Type number	PPP-TGV-N-XX	RCB-F9T-1-01

**Table 13: Product code formats**

The parts of the product code are explained in Table 14.

Code	Meaning	Example
PPP	Product family	RCB
TG	Platform	F9 = u-blox F9
V	Variant	T = Timing
N	Version	N: [0..9]
XX	Product detail	Describes hardware and firmware versions

**Table 14: Part identification code**

### 8.3 Ordering codes

Ordering code	Product	Remark
RCB-F9T-1	u-blox RCB-F9T	

**Table 15: Product ordering codes**



Product changes affecting form, fit or function are documented by u-blox. For a list of Product Change Notifications (PCNs) see our website at: <https://www.u-blox.com/en/product-resources>.

## Related documents

- [1] RCB-F9T Integration manual, [UBX-22004121](#)
- [2] TIM 2.20 Interface description [UBX-21048598](#)
- [3] ZED-F9T-10B Data sheet, [UBX-20033635](#)
- [4] Radio Resource LCS Protocol (RRLP), (3GPP TS 44.031 version 11.0.0 Release 11)



For regular updates to u-blox documentation and to receive product change notifications please register on our homepage <https://www.u-blox.com>.

## Revision history

Revision	Date	Name	Status / comments
R01	28-Apr-2021	rzuo	Advance information
R02	25-Feb-2022	byou	Early production information FW version TIM 2.20, sec. 1.3 Beidou B1C and NavIC SPS-L5 added
R03	30-Aug-2023	vema	Updated product status to mass production Added timepulse details in table Operating conditions