

USB Type-C / DisplayPort1.4 MST Hub

General Description

The KTM50x0 is an advanced DisplayPort1.4a MST hub with an integrated USB type-C de-multiplexer, targeted primarily for Mobile Notebook accessory and display applications. This device functions as a multi-stream audio-video splitter and protocol converter with an HDCP1.x/ HDCP2.3 repeater supporting both compressed (DSC) and uncompressed AV streams.

KTM50x0 has a DP alt-mode capable USB Type-C Upstream Facing Port (UFP). The four high speed lanes of UFP can receive DP1.4a MST audio-video and USB3.2 Gen2 data streams simultaneously. The input lane mapping is flexible and meets standard DP or the USB Type-C connector with flip orientation requirements. The incoming DP and USB signals are de-multiplexed, retimed, and transmitted on the Downstream Facing Ports (DFP). The KTM50x0 consists of three AC coupled DP/DP++ or DC coupled HDMI/DVI DFPs, each with four high-speed lanes and one USB port with USB3.2 TX and RX pair. The Stream Routing Logic in KTM50x0 allows flexible routing of incoming DP MST stream converted into any combination of MST or SST streams on any of the DFP video ports with link rate and lane count change option. Also, the SST stream can be replicated on two or more DFP ports. In addition, the DP SST stream can be converted into a HDMI or DVI output (TMDS signal format).

The combo receiver in KTM50x0 supports all DP standard data rates up to HBR3 (8.1 Gbps/lane) and USB3.2 Gen1 (5.0 Gbps) and Gen2 (10.0 Gbps). The dual mode (DP++) transmitters support DP standard data rates up to 8.1 Gbps/lane and TMDS data rates up to 6.0 Gbps/lane. The side-band channel uses 1.0 Mbps Manchester-coded AUX signaling for DP and DDC signaling up to 100kbps for the HDMI interface

Ordering Information

Part Number	Description	IC Package
RD4-5000	KTM50x0 RD4 Evaluation Kit	LFBGA 12x12mm / 0.65mm pitch

Detailed functionality of the IC is described in the KTM50x0 datasheet. Included in the kit are the following items:

Item #	Description	Quantity
1	Fully assembled printed circuit board	1
1	Reference Design Evaluation kit manual	1

EVAL Kit Photo

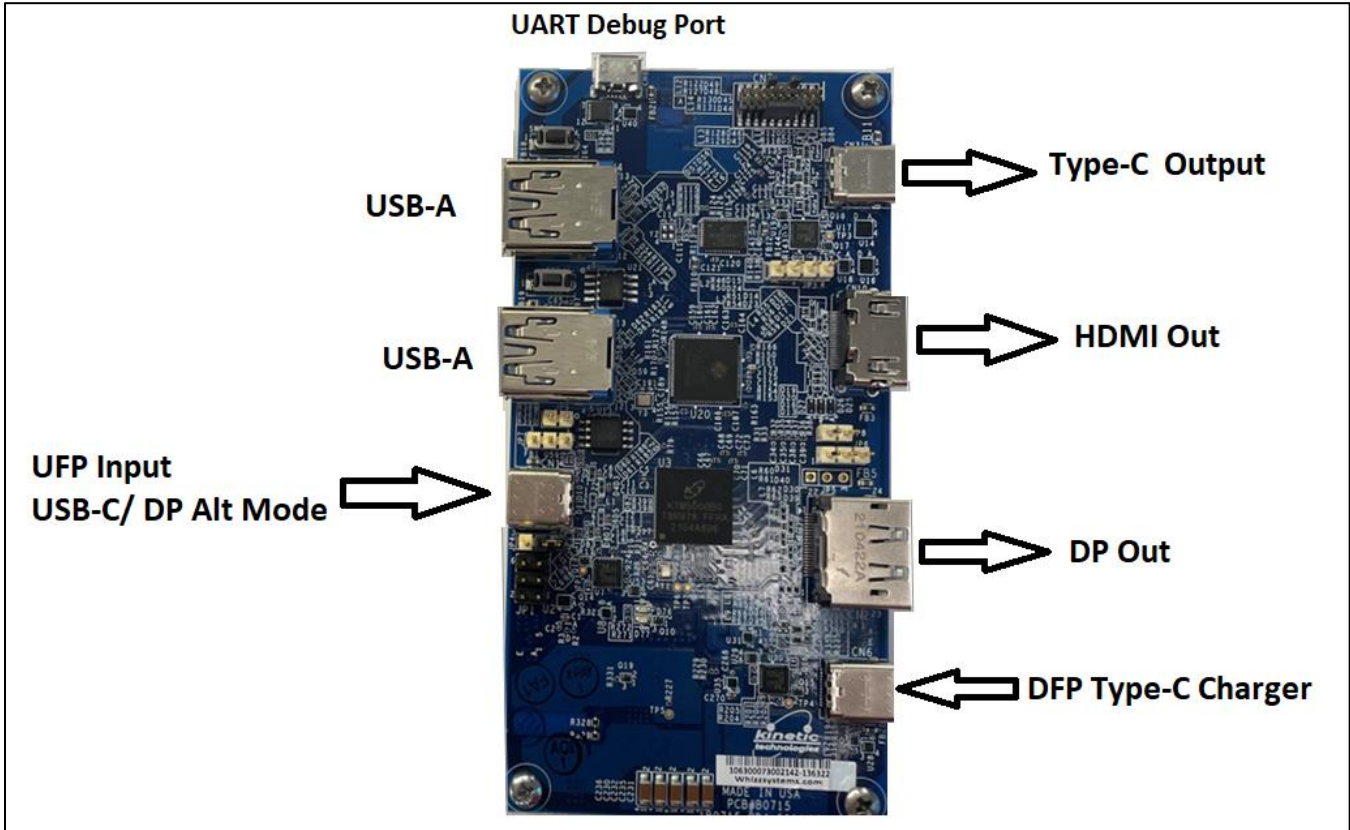

< Kinetic Technologies RD4 Type C MST Hub >

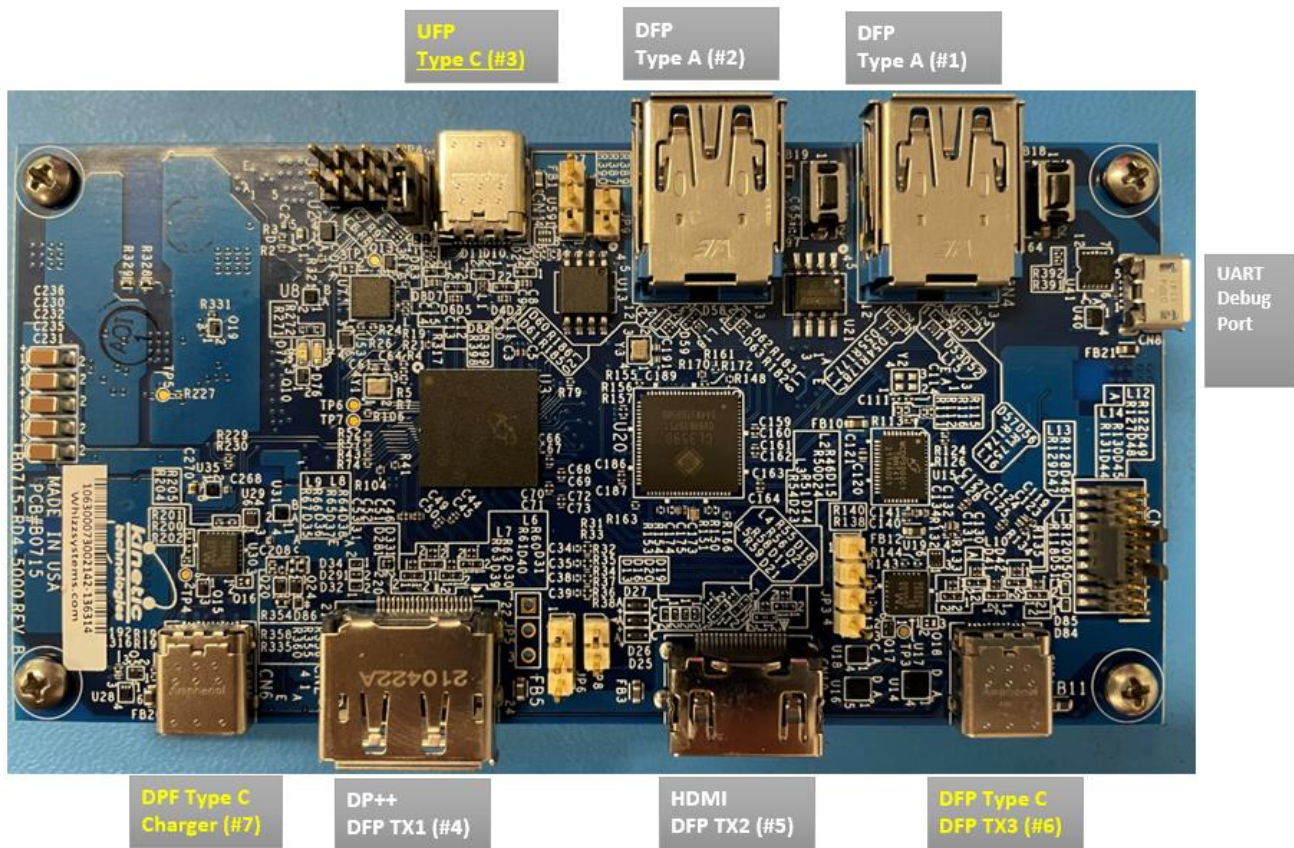

- #1. DFP Type A: USB 3.2 GEN2 and USB 2.0
 - #2. DFP Type A: USB 3.2 GEN2 and USB 2.0
 - #3. UFP Type C: Up to 60 Watts and DP1.4 and USB 3.2 GEN2 /USB 2.0
 - #4. DFP TX1: DP++ (DP1.4b or HDMI 2.0b)
 - #5. DFP TX2: HDMI2.0b
 - #6. DFP TX3 Type C: USB GEN2 and DP Alt Mode
 - #7. DFP Type C Charger: 100 Watts Preferred. Minimum 35 watt required to support all DFPs. (5 V Charger is not enough)
- UART: Debug and FW update

Connection Setup

1. DFP Type C Charger is required to turn on RD4.
2. UFP Type can't power up RD4 board because RD4 is designed as the dock station.
3. DPF Type C(TX3): Max 7.5 watt

Recommended Sequence: Not mandatory but in general

- Connect 100-Watt Type C Charger (> 35Watt) to DPF Type C Charger
- Connect DPF TX1 or TX2 or TX3 or both or all
- Connect UFP Type C

Evaluation Board Features

Design Features

- **DUT: KTM50x0**
- **Board Name: RD4-5000**
- **Power Supply:**
 - Type-C Charger 100 Watts Preferred. Minimum 35 watt required to support all DFPs
- **Interfaces:**
 - Input: USB Type C / DP Alt mode Supporting Billboard Functionality
 - Display Port: 1.62 / 2.74 / 5.4 / 8.1 Gbps, 1 / 2 / 4 lane configuration
 - USB3.2 GEN2 / USB 2.0:
 - Outputs:
 - TX1: DP++ (DP1.4/HDMI2.0b) transmitters supporting DP standard data rates up to 8.1 Gbps/lane
 - TX2: HDMI2.0b TMDS data rates up to 6.0 Gbps/lane.
 - TX3: Type-C: USB GEN2 and DP Alt Mode
 - 2x USB3.2 SSPx1 operation with USB Type-A Connector as DFP/5Gbps, 10Gbps
 - CPU Reset: 1x Push switch
 - Charging Port: USB type-C Receptacle
 - Handling voltage can be up to 20VDC as Power delivery specification
- **Components**
 - 3x MCDP9000 (USB PD3.0 Type-C Port Controller)
 - Small crystal operation: 25MHz with 2016 size (metric)
 - 16Mbit SPI Flash: MX25U1633FM2I (default) or compatibles¹.
 - 8Mbit SPI Flash: W25Q80DVSNIIG (default) or compatibles².
 - Protection Circuit
 - **ESD Diodes on**
 - RX: High Speed Line and AUX/HPD
 - TX2(HDMI): High Speed Line and DDC
 - USB3 SSP: High Speed Line
 - Pin header of G-Probe Interface (debug use)

1. Contact marketing for details on compatible memory

2. Contact marketing for details on compatible memory

- **VRM Block (Power Distribution Network)**
 - Lower cost components and smaller space
 - DCDC converter circuit compliant with noise requirement (<20mVpp)
 - Self-contained over-current protection circuit
 - Discharging load capacitors
- **Interfaces for debug:**
 - 1x G-Probe Interface on USB Micro-B connector (UART signals can be bypassed to external G-Probe card)
 - 1x JTAG(SWD) interface with J-Link 19pin
 - Trace pins of JTAG interface
 - Option of (footprint): 1x HDMI DDC pins (DC coupled) on DFP

System Overview

Functional Block Diagram

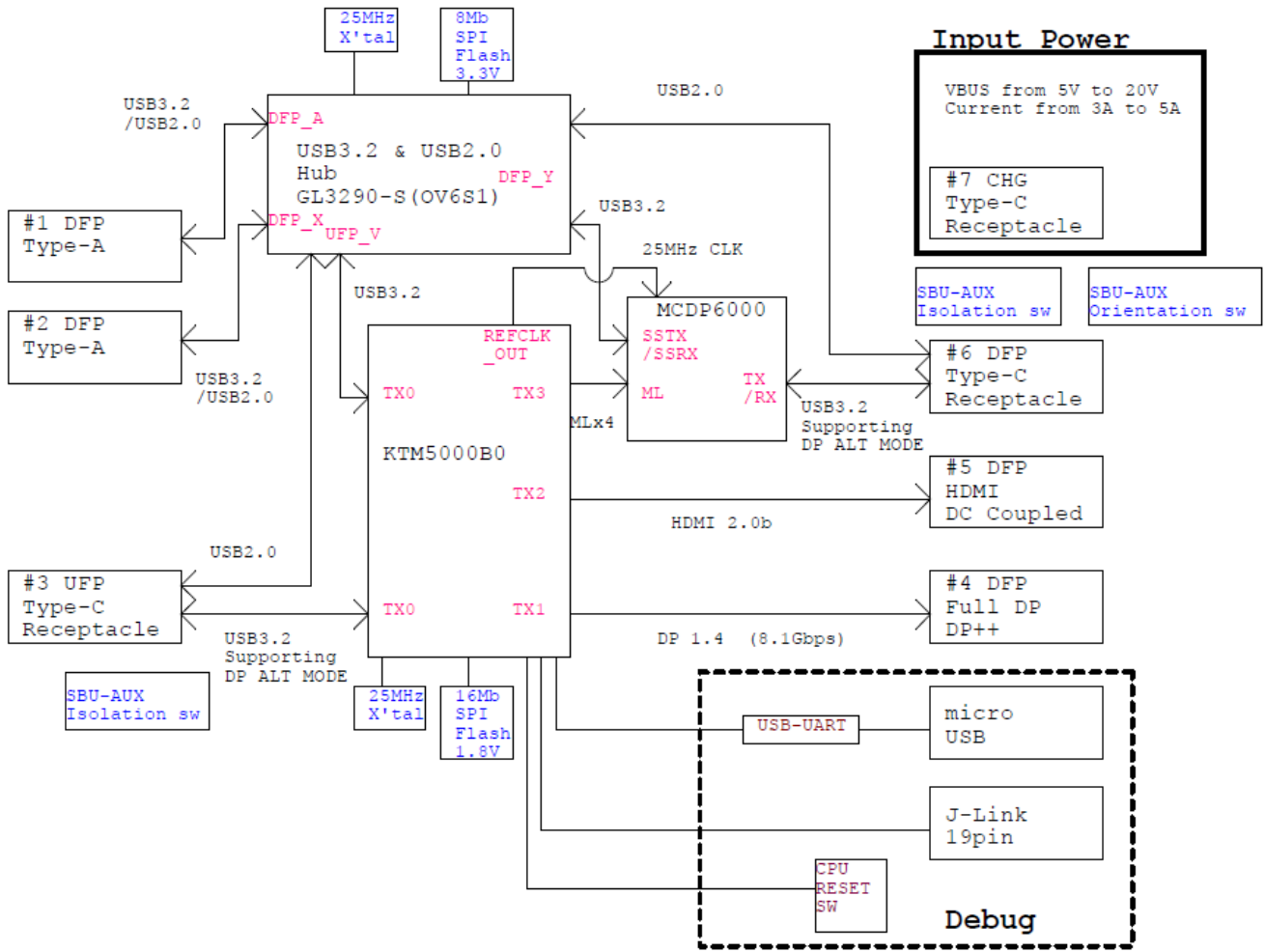

Figure 1. Functional Block Diagram

Recommended Type-C Chargers for the board

Manufacturer	Description
Hypr	100W TC Charger
Amazon (MBP)	100W TC Charger
Apple	87W TC Charger
Apple	65W TC Charger
Lenovo	65W TC Charger
Chrome	60W TC Charger