



SCALE IGBT and MOSFET Gate Driver
Product Overview 2018/2019



Power Everywhere

As the leading gate driver experts for medium- and high-power inverter systems, Power Integrations continuously invests in technology development, IC packaging, applications expertise and manufacturing excellence. This enables us to deliver high-performance gate driver solutions from 5 kW up to MW for blocking voltages up to 6.5 kV.

As well as addressing our traditional markets - industrial, traction, HVDC, PV – we now have AEC-Q100 qualification for some members of our SCALE-iDriver™ gate driver IC family. This development enables automotive designers to use our leading products in EV and HEV applications such as vehicle drive train, power conversion, on-board chargers and charging stations. We also offer optimized products for emerging SiC MOS applications, addressing that burgeoning market, we have added new SCALE-2 solutions for PrimePack3+™ and HVDC designs. These are just a few highlights in this new catalog.

By expanding our portfolio with conformal coating and burn-in services, we have further improved the robustness of our gate drivers – which were already renowned in industry for long life and operational safety - and we are able to respond faster to customer-specific requirements. With the implementation of a new state-of-the-art production board test system, we have further increased product reliability and now provide high-quality PCBA testing at the highest fault coverage rate without sacrificing throughput. This is demanded by customers in all our key market segments - automotive, industrial, traction, HVDC, PV, etc.

Check out this catalog to see if we have a solution for your application. If you cannot find an exact match for your requirement, we welcome the opportunity to develop a full-custom or tailored solution. Please contact your local sales office to discuss your specific needs.

Power Integrations – Power Everywhere.

Best regards,

Thomas Simonis

VP - Gate Drivers - Power Integrations

PI Databook

Notes at your Fingertips

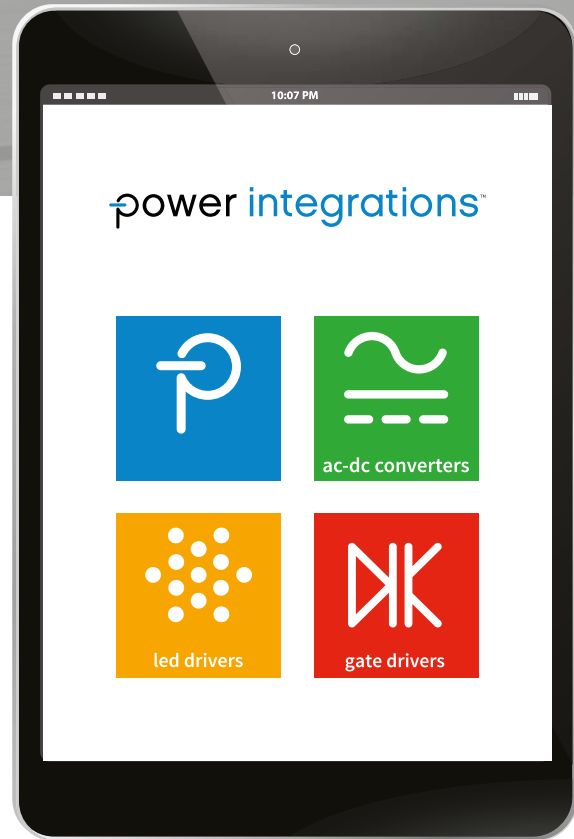

FULL LISTING OF POWER INTEGRATIONS PRODUCTS

- AC-DC converters
- LED driver ICs
- Gate drivers

USEFUL PRODUCT INFORMATION

- Technical documents including datasheets and application notes for all products

CONVENIENT TO USE

- Enhanced navigation
- Better interface
- Quicker performance
- Available in five languages

FREE FOR DOWNLOAD ON IOS OR ANDROID TODAY
SCAN QR CODE TO BEGIN DOWNLOAD



Download, print, email, and share product documents.



PI Databook gives you the ability to view content in five languages.



Read the latest Power Integrations news using popular news feed services: Facebook, Twitter, Weibo & LinkedIn.

CONTENTS

SCALE-iDriver Gate Driver ICs

Introduction.....	p.4-5
1200 V SID1112K, SID1132K, SID1152K, SID1182K.....	p. 6-7
600 / 650 V SID1151K, SID1181K.....	p. 8-9
1700 V SID1183K.....	p. 10-11
SID1102K.....	p. 12-13
SID1132KQ, SID1182KQ.....	p. 14-15

Gate Driver Cores

Introduction.....	p. 16-17
2SC0106T.....	p. 18-19
2SC0115T.....	p. 20-21
2SC0108T.....	p. 22-23
2SC0435T.....	p. 24-25
2SD300C17.....	p. 26-27
2SC0650P.....	p. 28-29
1SC2060P.....	p. 30-31
2SC0535T.....	p. 32-33
2SC0635T.....	p. 34-35
1SC0450V2, 1SC0450E2.....	p. 36-37

Plug-and-Play Gate Drivers

Introduction.....	p. 38-39
2SP0115T.....	p. 40-41
2SP0320T2, 2SP0320V2.....	p. 42-43
2SP0325V2, 2SP0325T2.....	p. 44-45
1SP0635V2.....	p. 46-47
1SP0340V2 and DC-DC Converter ISO5125I.....	p. 48-49
1SP0335 and DC-DC Converter ISO5125I.....	p. 50-51
DC-DC Converter ISO5125I.....	p. 52

Application Notes.....	p. 53
------------------------	-------

Conformal Coating.....	p. 54-55
------------------------	----------

SiC MOSFET Gate Driver

600 V to 4500 V.....	p. 56-57
----------------------	----------

SCALE-iDriver Gate Driver ICs INTRODUCTION

Power Integrations is a technology and market leader in mid- and high-power gate drivers. Using highly integrated technology, the company's gate drivers employ 85% fewer components than other commonly-available solutions. Power Integrations has 30 years' history of supporting demanding industries such as traction, power generation, power transmission and industrial automation with products that combine outstanding reliability, best-in-class performance and competitive pricing.

INNOVATIVE TECHNOLOGY

The SCALE-iDriver family of gate driver ICs, optimized for driving both IGBTs and MOSFETs, are the first products to bring Power Integrations' pioneering FluxLink™ magneto-inductive bi-directional communications technology to 1200 V and 1700 V driver applications.

- FluxLink technology eliminates the need for short-lived opto-electronics and associated compensation circuitry, thereby enhancing operational stability while reducing system complexity.
- Advanced system safety and protection features, commonly found in medium- and high-voltage applications, enhance product reliability.
- Innovative eSOP™ package features 9.5 mm of creepage and a Comparative Tracking Index (CTI) = 600, ensuring substantial operating voltage margin and high system reliability.

AUTOMOTIVE APPLICATIONS

Power Integrations SCALE-iDriver ICs for automotive applications (SID1132KQ/SID1182KQ) are AEC-Q100 qualified, can drive up to 8 A and support 600 V, 650 V and 1200 V IGBT and SiC inverter designs up to several hundred kW without a booster stage.

SCALE-IDRIVER GATE DRIVER ICs

The SCALE-iDriver family of galvanic isolated single-channel gate driver ICs ranges in output current from 1 A up to 8 A – the industry's highest without needing an external booster amplifier. SCALE-iDriver devices are optimized for driving IGBT and MOSFETs from 600 V to 1700 V, and enable inverters to be built up to 110 kW using only a few external components.



SCALE-iDRIVER GATE DRIVER IC PORTFOLIO

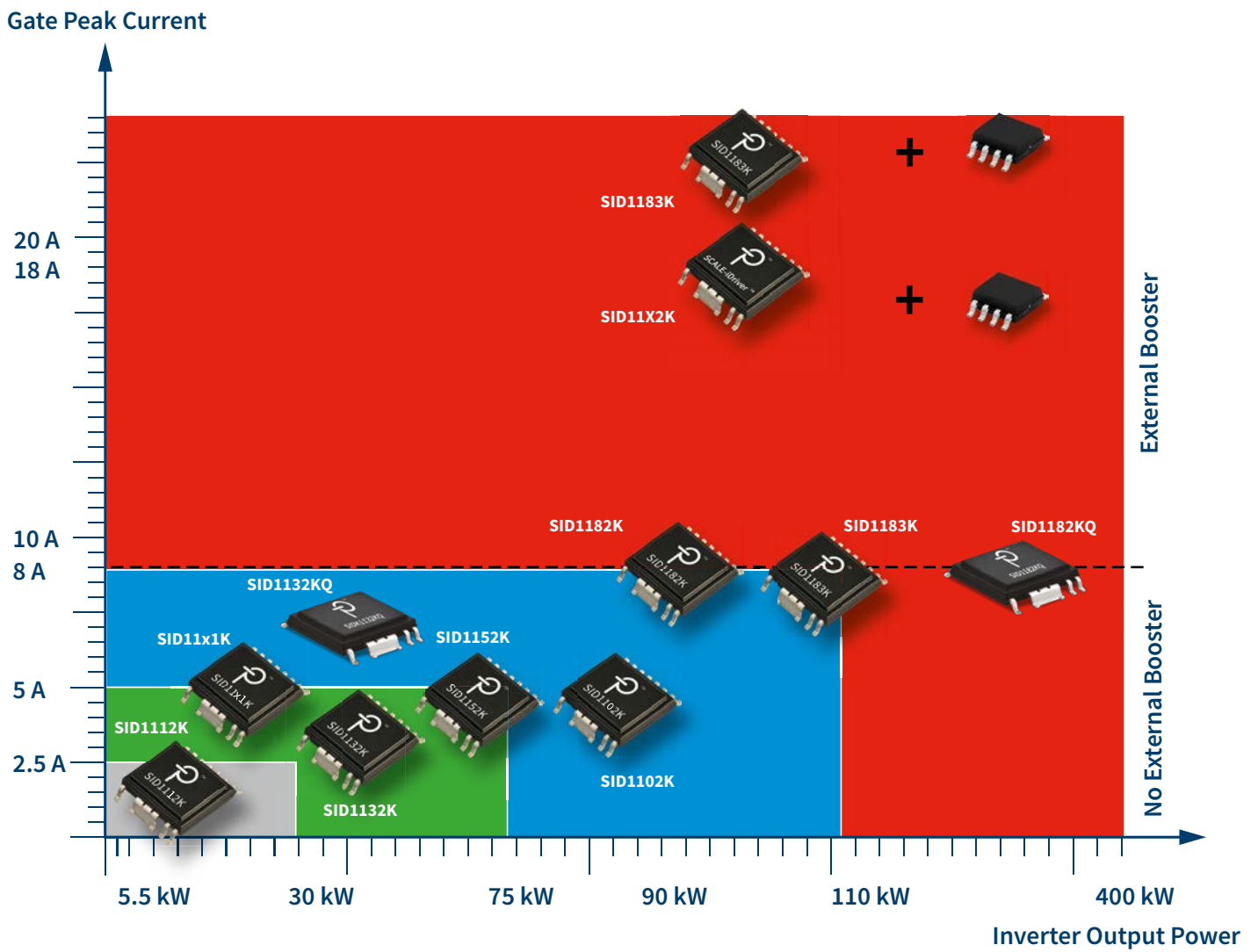

1200 V SCALE-iDriver Gate Driver
SID1112K, SID1132K, SID1152K, SID1182K



Galvanically-reinforced isolated single-channel gate driver IC has output currents from 1 A to 8 A; drives inverters of up to 110 kW using only a few external components.

APPLICATIONS

- Industrial drives (GPD, VFD, AC drives and servo drives)
- Power supplies (UPS, large flat panel, industrial filter, lighting, etc.)
- Photovoltaic inverter (low power, high-power commercial)
- Industrial (welding, health care, plasma, inductive heating)
- EV charger (supply and station)

CERTIFICATION

- Reinforced isolation according to VDE0884-10 and IEC60747-10
- UL1577 certified: E358471 complies with IEC61000-4-8 and IEC61000-4-9 standards

KEY FEATURES

- eSOP package: CTI 600, 9.5 mm creepage and clearance
- Increased reliability, smaller size, lower system cost
- SCALE technology reduces component count and system cost; smaller and simpler PCB
- ASSD function controls di/dt in desaturation without adjustment or development work
- VEE regulator avoids 0 V switching: smaller (CHECK) RG(on) resistor and reduced IGBT turn-on losses
- Reduced IGBT switching losses when compared to optocoupler designs

KEY DATA OVERVIEW

Parameter	Min	Typical	Max	Unit
Primary-side supply voltage (V_{VCC})	4.75	5	5.25	V
Secondary-side total supply voltage (V_{TOT})	22	25	28	V
Maximum gate sourcing peak current (I_{GH})		7.3		A
Maximum gate sinking peak current (I_{GL})		8		A
Operating switching frequency (f_s)	0	20	75	kHz
Propagation delay jitter			± 5	ns
Turn-on propagation delay time ($t_{p(LH)}$)		253		ns
Turn-off propagation delay time ($t_{p(HL)}$)		262		ns
Minimum turn-on and off PWM pulses extension ($t_{GE(MIN)}$)			650	ns
Creepage distance primary-secondary (L_2)	9.5			mm
Clearance distance primary-secondary (L_1)	9.5			mm
Tracking resistance (comparative tracking index - CTI)		600		
Max. package dissipated power (T_s)			1.79	W
100% production withstanding isolation voltage test (V_{TEST})	6			kVRMS
100% production partial discharge test ($V_{PD(m)}$)	2652			Vpeak

APPLICATION CIRCUIT (SID11X2K)

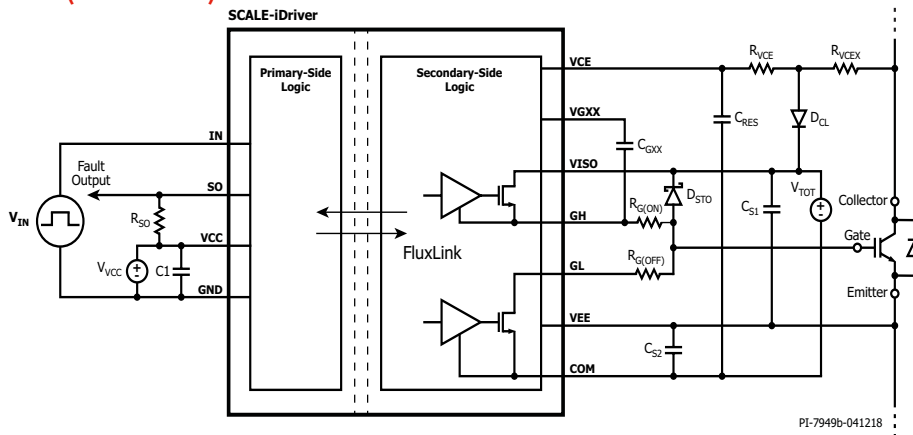

REFERENCE DESIGNS

<https://gate-driver.power.com/design-support/reference-designs/>

RDHP	Product	Technology	Channels	Voltage Class	Power Module Package	Related Power Module	Interface	Application
RDHP-1526	SID11x2K	SCALE-iDriver	2	1200 V	Any	up to 3600 A	Electrical (5 V logic)	General purpose drives, UPS, PV and others
RDHP-1608	SID11x2K	SCALE-iDriver	2	1200 V	Any	up to 600 A	Electrical (5 V logic)	General purpose drives, UPS, PV and others

ORDERING INFORMATION

Part Number	Product Rated Current	IGBT Collector Current Ratings * (without booster)	Ordering Code
SID1112K	1 A	Up to 50 A	SID1112K (delivered in tubes - 48pcs) SID1112K-TL (delivered in Tape & Reel - 1000pcs)
SID1132K	2.5 A	Up to 100 A	SID1132K (delivered in tubes - 48pcs) SID1132K-TL (delivered in Tape & Reel - 1000pcs)
SID1152K	5 A	Up to 300 A	SID1152K (delivered in tubes - 48pcs) SID1152K-TL (delivered in Tape & Reel - 1000pcs)
SID1182K	8 A	Up to 600 A	SID1182K (delivered in tubes - 48pcs) SID1182K-TL (delivered in Tape & Reel - 1000pcs)

600 / 650 V SCALE-iDriver Gate Driver SID1151K, SID1181K



Up to 8 A single channel IGBT/MOSFET gate driver providing reinforced galvanic isolation up to 650 V blocking voltage and basic isolation up to 1200 V.

APPLICATIONS

- Delivery vehicles
- General purpose drives
- General industrial equipment

CERTIFICATION

- Reinforced isolation according to VDE0884-10 and IEC60747-10
- UL1577 certified: E358471 complies with IEC61000-4-8 and IEC61000-4-9 standards

KEY FEATURES

- Split outputs providing up to 8 A peak drive current
- Integrated FluxLink technology
- Rail-to-rail stabilized output voltage
- Unipolar supply voltage for secondary-side
- Suitable for 600 V / 650 V / 1200 V IGBT and MOSFET switches
- Providing basic isolation up to 1200 V blocking voltage
- Up to 75 kHz switching frequency
- 260 ns low propagation delay time
- ±5 ns propagation delay jitter
- -40 °C to 125 °C operating ambient temperature
- High common-mode transient immunity
- eSOP package with 9.5 mm creepage and clearance

KEY DATA OVERVIEW

Parameter	Min	Typical	Max	Unit
Primary-side supply voltage (V_{VCC})	4.75	5	5.25	V
Secondary-side total supply voltage (V_{TOT})	22	25	28	V
Maximum gate sourcing peak current (I_{GH})		7.3		A
Maximum gate sinking peak current (I_{GL})		8		A
Operating switching frequency (f_s)	0	20	75	kHz
Propagation delay jitter			± 5	ns
Turn-on propagation delay time ($t_{p(LH)}$)		253		ns
Turn-off propagation delay time ($t_{p(HL)}$)		262		ns
Minimum turn-on and off PWM pulses extension ($t_{GE(MIN)}$)			650	ns
Creepage distance primary-secondary (L_2)	9.5			mm
Clearance distance primary-secondary (L_1)	9.5			mm
Tracking resistance (comparative tracking index - CTI)		600		
Max. package dissipated power (T_s)			1.79	W
100% production withstanding isolation voltage test (V_{TEST})	6			kVRMS
100% production partial discharge test ($V_{PD(m)}$)	2652			Vpeak

APPLICATION CIRCUIT (SID11X1K)

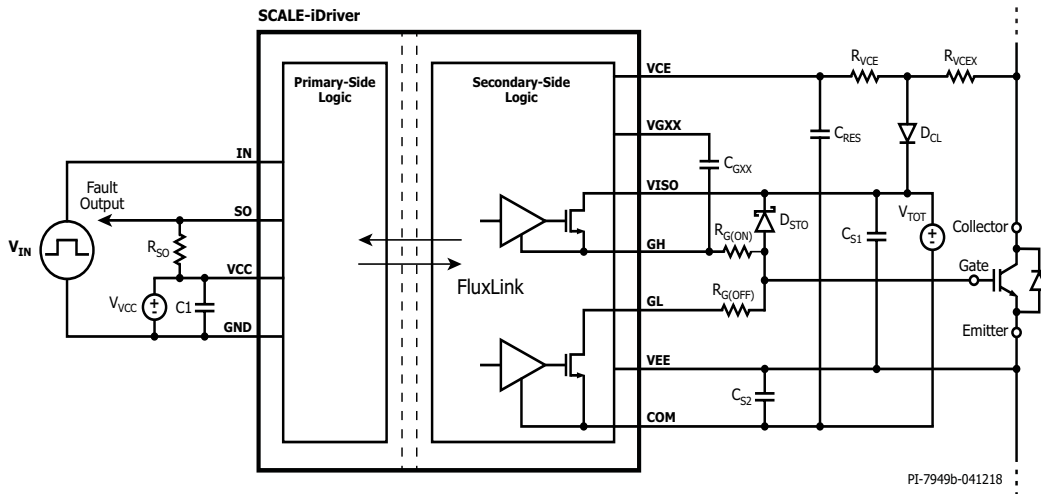

ORDERING INFORMATION

Part Number	Product Rated Current	IGBT Collector Current Ratings * (without booster)	Ordering Code
SID1151K	5 A	Up to 300 A	SID1151K (delivered in tubes - 48pcs) SID1151K-TL (delivered in Tape & Reel - 1000pcs)
SID1181K	8 A	Up to 600 A	SID1181K (delivered in tubes - 48pcs) SID1181K-TL (delivered in Tape & Reel - 1000pcs)

1700 V SCALE-iDriver Gate Driver SID1183K

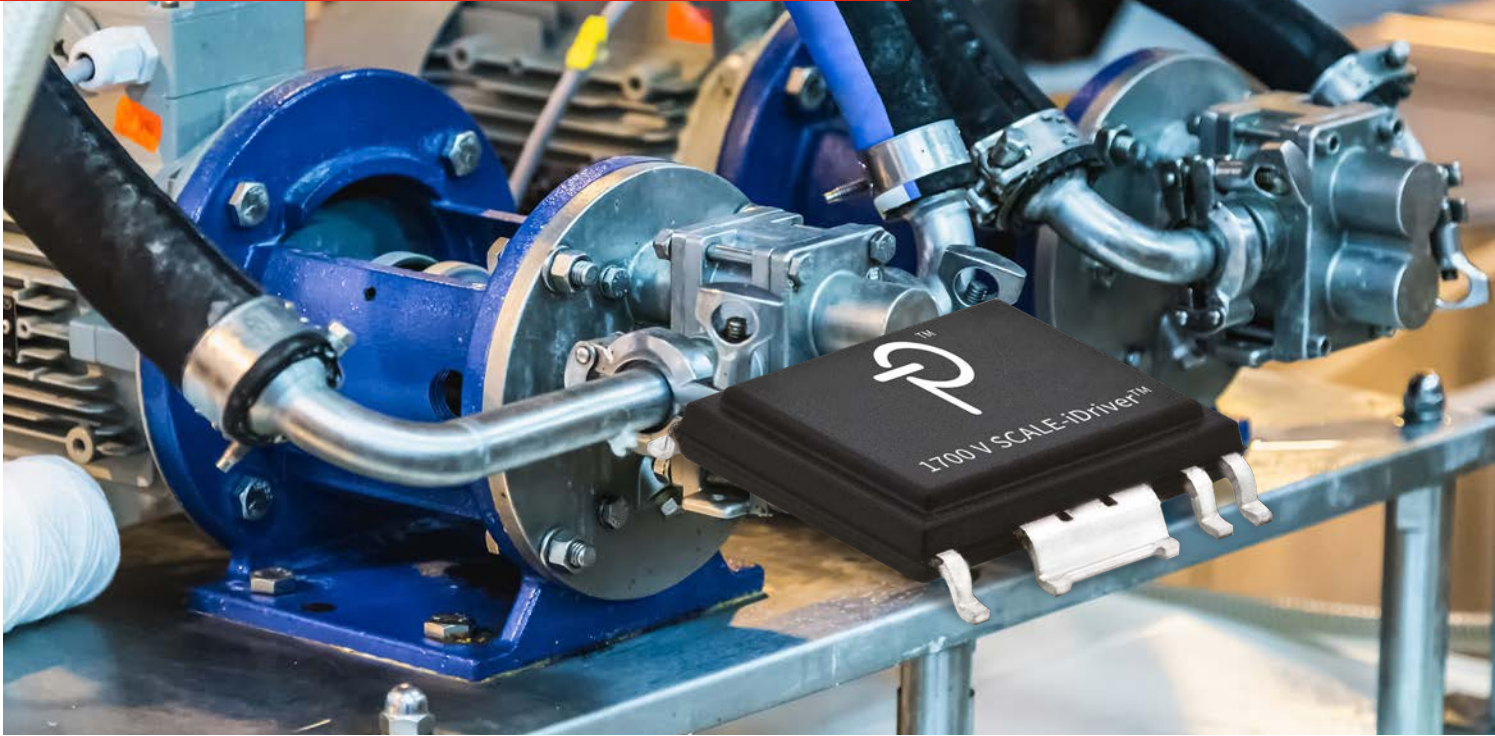

Single-channel gate driver for up to 1700 V application with basic isolation.



APPLICATIONS

- VFD (Variable Frequency Drives) AC drives from 500 V to 690 V
- PV (Photo Voltaic) with 1500 V DC bus, three-level and interleaved topologies
- Medium Voltage Drive (MVD) and LV STATCOM
- Commercial e-mobility

CERTIFICATION

- Basic isolation according to VDE0884-10 and IEC60747-10
- UL1577 certified: E358471 complies with IEC61000-4-8 and IEC61000-4-9 standards

KEY FEATURES

- Full platform solution: same device across the whole voltage range from 1200 V to 1700 V
- FluxLink provides basic isolation for applications using 1700 V IGBTs
- eSOP package provides CTI 600 and >9.5 mm creepage and clearance distance
- SCALE features reduced component count and system cost, smaller and simpler PCB
- ASSD function controls di/dt in desaturation without adjustment or development work
- VEE regulator avoids 0 V switching lower RG(n) resistor reduced turn-on losses
- Switching up to 1700 V and 600 A IGBT modules without external boosters (ASSD function still effective)
- Reduced IGBT switching losses

KEY DATA OVERVIEW

Parameter	Min	Typical	Max	Unit
Primary-side supply voltage (V_{VCC})	4.75	5	5.25	V
Secondary-side total supply voltage (V_{TOT})	22	25	28	V
Maximum gate sourcing peak current (I_{GH})		7.3		A
Maximum gate sinking peak current (I_{GL})		8		A
Operating switching frequency (f_s)	0	20	75	kHz
Propagation delay jitter			±5	ns
Turn-on propagation delay time ($t_{p(LH)}$)		253		ns
Turn-off propagation delay time ($t_{p(HL)}$)		262		ns
Minimum turn-on and off PWM pulses extension ($t_{GE(MIN)}$)			650	ns
Creepage distance primary-secondary (L2)	9.5			mm
Clearance distance primary-secondary (L1)	9.5			mm
Tracking resistance (comparative tracking index - CTI)		600		
Max. package dissipated power (P_s)			1.79	W
100% production withstanding isolation voltage test (V_{TEST})	6			kVRMS
100% production partial discharge test ($V_{PD(M)}$)	2550			Vpeak

APPLICATION CIRCUIT (SID1183K)

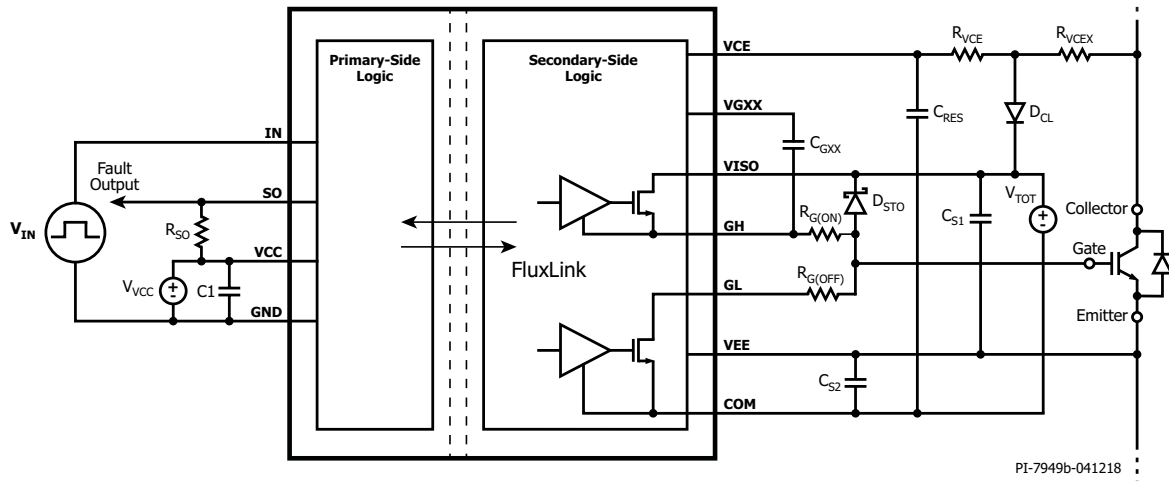

REFERENCE DESIGN

<https://gate-driver.power.com/design-support/reference-designs/>



RDHP	Part Number	Technology	Channels	Voltage Class	Power Module Package	Related Power Module	Interface	Application
RDHP-1702	SID1183K	SCALE-iDriver	2	1700 V	Any	N/A	Electrical (5V logic)	General purpose drives, UPS and others

ORDERING INFORMATION

Part Number	Product Rated Current	IGBT Collector Current Ratings *(without booster)	Ordering Code
SID1183K	8 A	Up to 600 A	SID1183K (delivered in tubes - 48pcs) SID1183K-TL (delivered in Tape & Reel - 1000pcs)

SCALE-iDriver Gate Driver SID1102K



Single-channel IGBT and MOSFET gate driver in eSOP wide-body package with reinforced galvanic isolation.

APPLICATIONS

- UPS
- Standard AC/drive and VFD
- Photovoltaic /solar
- Commercial air conditioners
- DC-charger
- Welding

CERTIFICATION

- Reinforced isolation according to VDE0884-10 and IEC60747-10
- UL1577 certified: E358471 complies with IEC61000-4-8 and IEC61000-4-9 standards

KEY FEATURES

- Straightforward 5 A IGBT gate driver with scalable external N-channel MOSFET booster up to 60 A peak gate current (N-channel has lower losses and lowers total system cost), with wide flexible use to drive IGBT modules up to 1200 V and IGBT current 50 A up to 3600 A
- Single channel providing up to 5 A peak gate drive current without boosters
- Undervoltage lockout
- Integrated FluxLink technology provides safe isolation between primary-side and secondary-side
- Rail-to-rail stabilized output voltage
- Suitable for 600 V / 650 V / 1200 V IGBT and MOSFET switches
- Up to 75 kHz switching frequency
- ± 5 ns propagation delay jitter
- -40 °C to 125 °C operating ambient temperature
- eSOP package with 9.5 mm creepage and clearance

KEY DATA OVERVIEW

Parameter	Min	Typical	Max	Unit
Primary-side supply voltage (V_{VCC})	4.75	5	5.25	V
Secondary-side total supply voltage (V_{TOT})	22	25	28	V
Maximum gate sourcing peak current (I_{GH})		3.3		A
Maximum gate sinking peak current (I_{GL})		5		A
Operating switching frequency (f_s)	0	75	250	kHz
Propagation delay jitter			± 5	ns
Turn-on propagation delay time ($t_{p(LH)}$)		262		ns
Turn-off propagation delay time ($t_{p(HL)}$)		262		ns
Minimum turn-on and off PWM pulses extension ($t_{GE(MIN)}$)			650	ns
Creepage distance primary-secondary (L2)	9.5			mm
Clearance distance primary-secondary (L1)	9.5			mm
Tracking resistance (comparative tracking index - CTI)		600		
Max. package dissipated power (T_s)			1.79	W
100% production withstanding isolation voltage test (V_{TEST})	6			kVRMS
100% production partial discharge test ($V_{PD(m)}$)	2652			Vpeak

APPLICATION CIRCUIT (SID1102K)

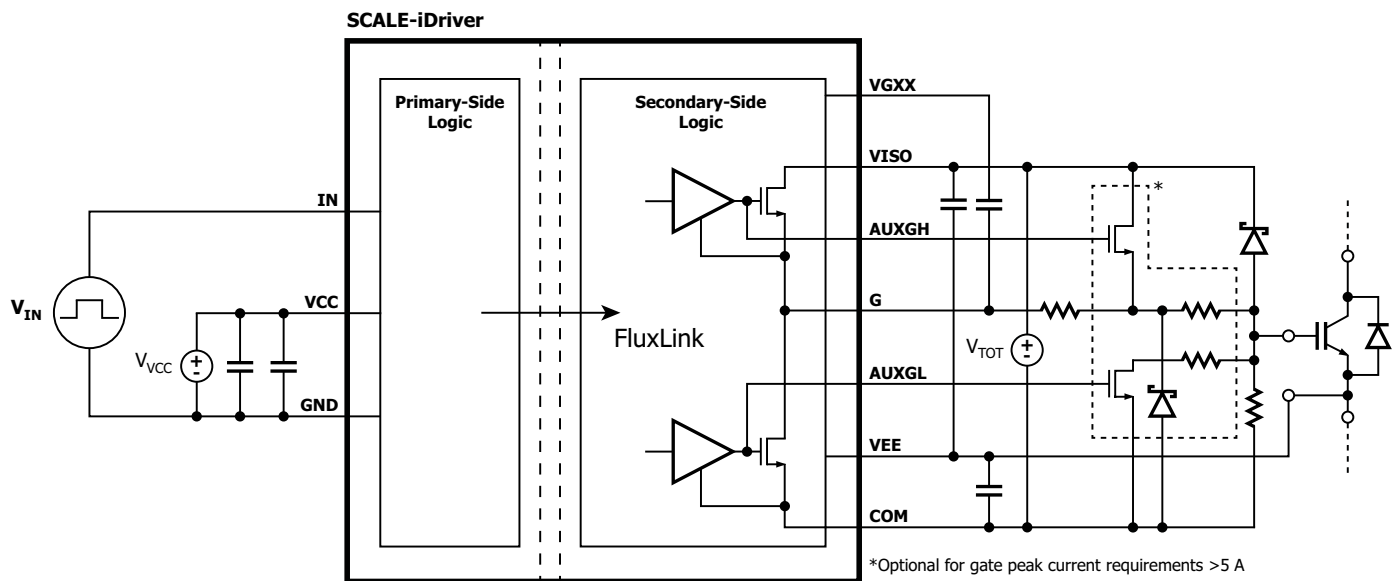

ORDERING INFORMATION

Part Number	Product Rated Current	IGBT Collector Current Ratings *(without booster)	Ordering Code
SID1102K	5 A	Up to 300 A	SID1102K (delivered in tubes - 48pcs) SID1102K-TL (delivered in Tape & Reel - 1000pcs)

Automotive Application Gate Drivers SID1132KQ, SID1182KQ



2.5 A and up to 8 A single-channel IGBT/MOSFET gate driver for automotive applications providing reinforced galvanic isolation.

APPLICATIONS

- Electric vehicle power train
- Electric vehicle on-board chargers and charger stations
- High reliability drivers and inverters

CERTIFICATION

- AEC-Q100 qualified reaching automotive grade level 1
- Full safety and regulatory compliance
- 100% production partial discharge test
- 100% production HIPOT compliance testing at 6 kV RMS 1 s
- Reinforced isolation according to VDE0884-10 and IEC60747-10
- UL1577 certified: E358471 complies with IEC61000-4-8 and IEC61000-4-9 standards

KEY FEATURES

- Split outputs providing up to 8 A peak drive current
- Integrated FluxLink technology providing safe isolation between primary-side and secondary-side
- Rail-to-rail stabilized output voltage
- Unipolar supply voltage for secondary side
- Suitable for 600 V / 650 V / 1200 V IGBT and MOSFET switches
- Up to 75 kHz switching frequency
- 260 ns propagation delay time
- ± 5 ns propagation delay jitter
- -40 °C to $+125$ °C operating ambient temperature
- High common-mode transient immunity
- eSOP package with 9.5 mm creepage and clearance

KEY DATA OVERVIEW

Parameter	Min	Typical	Max	Unit
Primary-side supply voltage (V_{VCC})	-0.5	5	6.5	V
Secondary-side total supply voltage (V_{TOT})	-0.5	25	30	V
Maximum gate sourcing peak current (I_{GH})		7.3		A
Maximum gate sinking peak current (I_{GL})		8		A
Operating switching frequency (f_s)		20	75	kHz
Propagation delay jitter			± 5	ns
Turn-on propagation delay time ($t_{p(LH)}$)		253		ns
Turn-off propagation delay time ($t_{p(HL)}$)		262		ns
Minimum turn-on and off PWM pulses extension ($t_{GE(MIN)}$)			650	ns
Creepage distance primary-secondary (L2)	9.5			mm
Clearance distance primary-secondary (L1)	9.5			mm
Tracking resistance (comparative tracking index - CTI)		600		
Max. package dissipated power (P_s)			1.79	W
100% production withstanding isolation voltage test (V_{TEST})	6			kVRMS
100% production partial discharge test ($V_{PD(M)}$)	2550			Vpeak

APPLICATION CIRCUIT (SID1132KQ AND SID1182KQ)

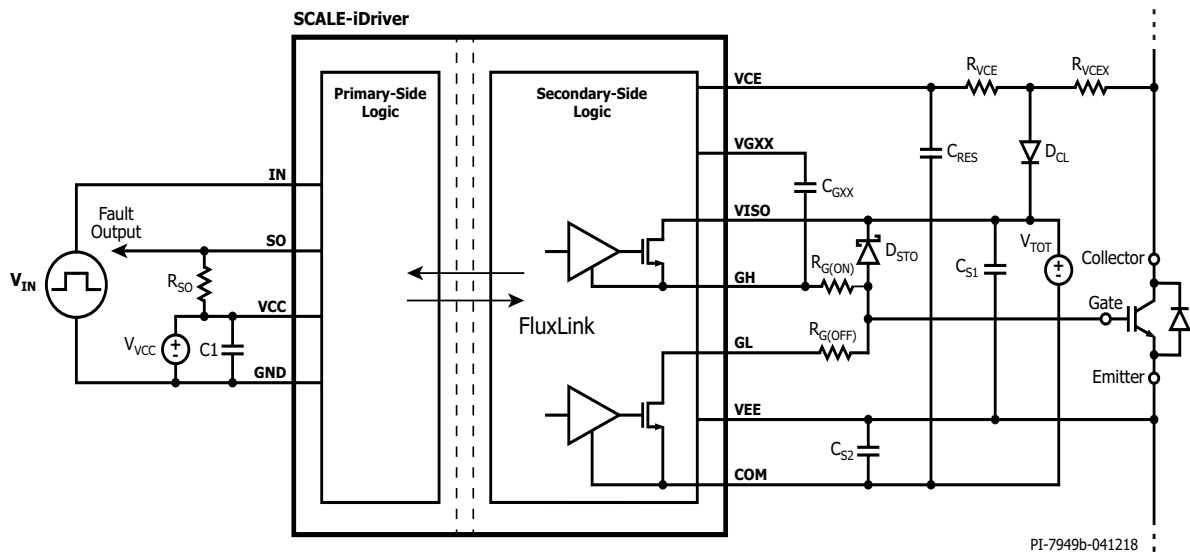

ORDERING INFORMATION

Part Number	Product Rated Current	IGBT collector current ratings *(without booster)	Ordering Code
SID1132KQ	2.5 A	Up to 100 A	SID1182KQ (delivered in tubes - 48pcs) SID1182KQ-TL (delivered in Tape & Reel - 1000pcs)
SID1182KQ	8 A	Up to 600 A	SID1182KQ (delivered in tubes - 48pcs) SID1182KQ-TL (delivered in Tape & Reel - 1000pcs)

Gate Driver Cores INTRODUCTION

Power Integrations is a technology and market leader in mid- and high-power gate drivers. Using highly integrated technology, the company's gate drivers employ 85% fewer components than other commonly-available solutions. Power Integrations has 30 years' history of supporting demanding industries such as traction, power generation, power transmission and industrial automation with products that combine outstanding reliability, best-in-class performance and competitive pricing.

INNOVATIVE TECHNOLOGY

Power Integrations' SCALE-2 IGBT and MOSFET gate drivers use an ASIC chip set specifically designed to reduce count, save space and increase product reliability and functionality. A recent technology development, SCALE-2+, enables Soft Shut Down (SSD) to be implemented in the event of a short circuit without requiring additional components (SSD function exclusive in 2SC0106T and 2SC0108T). This is particularly beneficial in applications with low stray-inductance where Advanced Active Clamping (AAC) may not be required.

EVERYTHING A DESIGNER NEEDS

Power Integrations' gate driver cores incorporate driver functions including galvanic isolation, protection functions, DC-DC converter, etc., on board presenting designers with a complete yet extremely flexible system solution.

Gate driver cores are available with blocking voltage capabilities from 600 V to 6500 V and output power from 1 W to 20 W per channel. They are also suitable for driving wide bandgap devices based on emerging materials such as Gallium Nitride (GaN) and Silicon Carbide (SiC) at frequencies at up to 500 kHz. Gate driver cores are supported by reference designs for fast design-ins.

DESIGN SUPPORT AND CUSTOMISATION

Power Integrations develops reference designs and semi-custom gate drive designs based on the company's driver cores and produces full-custom drivers using the company's SCALE-2 platform for large projects.



SCALE-2 AND SCALE-2+ GATE DRIVER CORES PORTFOLIO

IGBT Module Blocking Voltage

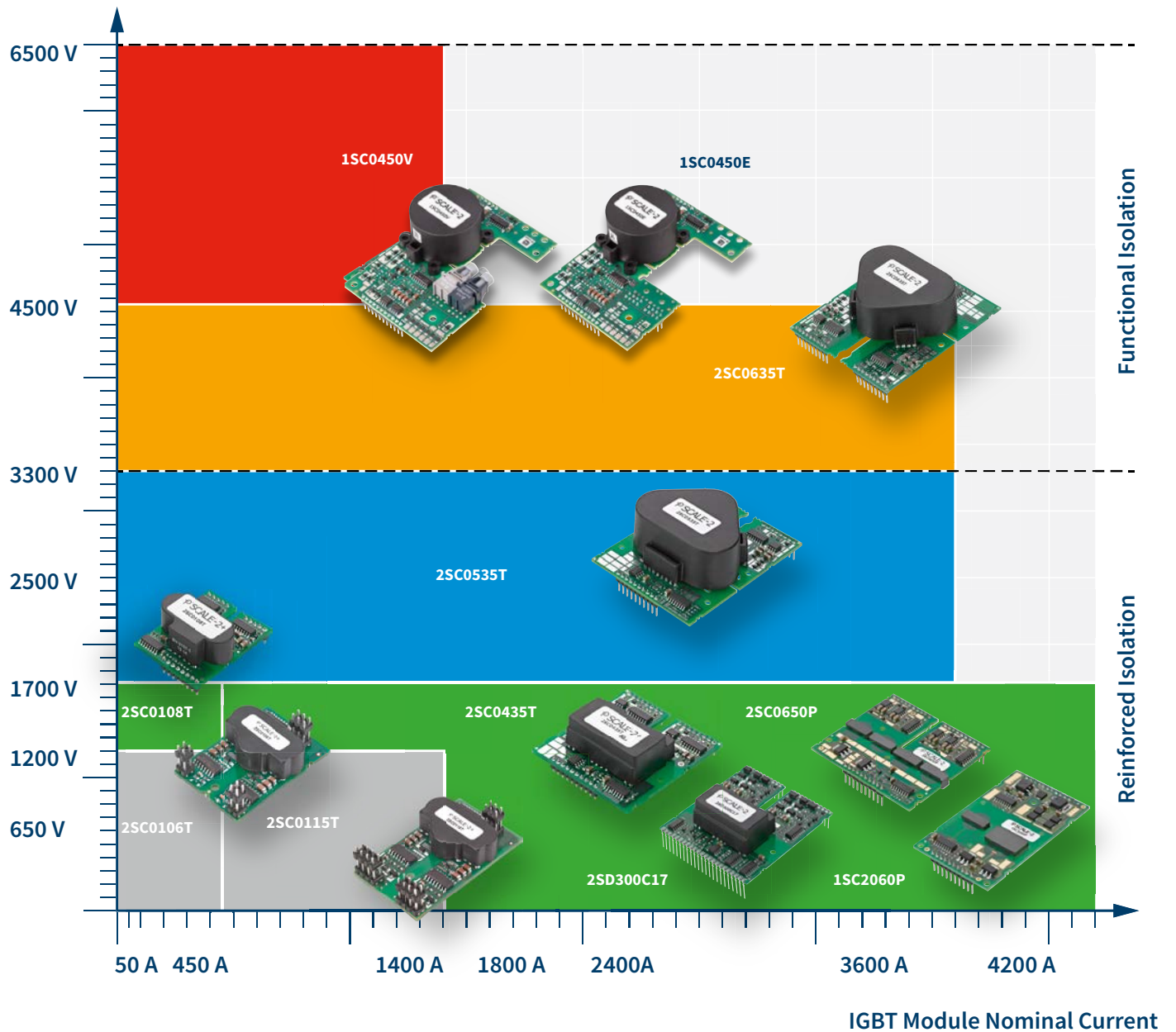

SCALE-2+ Gate Driver Core 2SC0106T



Dual-channel gate driver core for 1200 V IGBTs – The alternative to optocoupler driver solutions for inverter designs requiring reinforced isolation in the 37 kW to 110 kW power range.

APPLICATIONS

- Industrial motor drives
- Premium drives
- Uninterruptible power supplies (UPS)
- Solar inverters
- Electro/hybrid drive vehicles
- Switch-mode power supplies (SMPS)
- Medical (MRT, CT, X-ray)
- Welding

CERTIFICATION

- Reinforced isolation coordination according to IEC

KEY FEATURES

- Dual-channel driver core for up to 1200 V
- ± 6 A gate current, +15 V/-8 V
- 1 W @ 85 °C per channel
- On-board regulated power supply
- High reliability (reduced component count)
- Direct paralleling capability
- Short-circuit protection, undervoltage lockout
- <100 ns delay time up to 50 kHz; jitter ± 3 ns
- -40 °C to +85 °C (105 °C with derating)
- Lead-free
- Soft Shut Down (SSD)

PRODUCT DESCRIPTION

An output current of ± 6 A and 1 W driver power at 85 °C is available per channel, making the 2SC0106T an ideal driver platform for universal usage in small and medium power applications. The driver provides a gate voltage swing of +15 V/-8 V. The turn-on voltage is regulated to maintain a stable 15 V regardless of the output power level. Outstanding EMC performance enables safe and reliable operation even in harsh industrial environments.

KEY DATA OVERVIEW

Parameter	Min	Typical	Max	Unit
Nominal supply voltage		15		V
Supply current @ $f_{in}=0$ Hz		40		mA
Supply current, full load		300		mA
Output power per channel		1		W
Gate voltage		+15/-8		V
Peak output current (gate current)	-6		+6	A
Switching frequency (f_s)	0		50	kHz
Duty cycle	0		100	%
Creepage distance primary-secondary	9			mm
Creepage distance secondary-secondary	5.5			mm
Clearance distance primary-secondary	9			mm
Clearance distance secondary-secondary	5.5			mm
Dielectric test voltage	4000			V _{AC}
Partial discharge extinction voltage	1800			V _{peak}
dv/dt immunity, input-to-output			50	kV/us
Operating temperature	-40		+105	°C

APPLICATION CIRCUIT (2SC0106T)

The 2SC0106T is a cost-effective driver core equipped with Power Integrations' latest SCALE-2+ chipset which consists of two ASICs that provide the main functions required to implement intelligent gate drivers. Devices include all functionality necessary for an advanced dual-channel gate driver: isolated DC-DC converter, short-circuit protection, Soft Shut Down (SSD) and supply voltage monitoring.

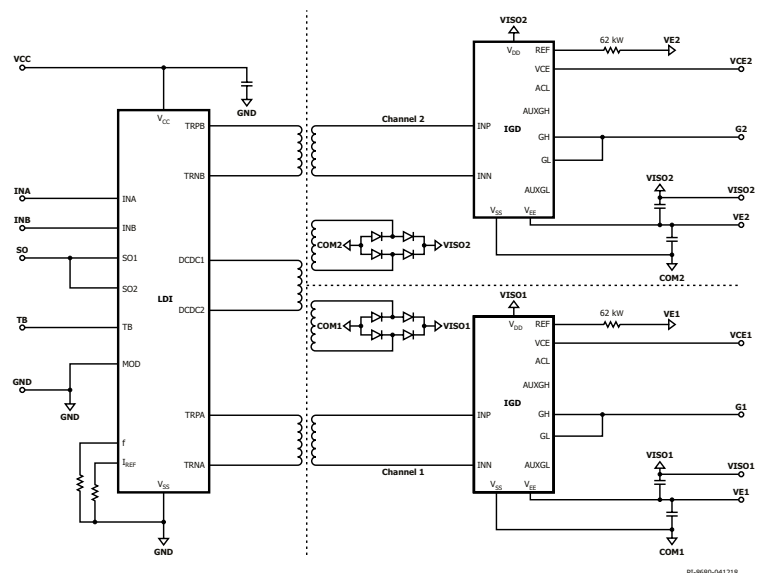

REFERENCE DESIGN

<https://gate-driver.power.com/design-support/reference-designs/>



RDHP	Part Number	Technology	Channels	Voltage Class	Power Module Package	Related Power Module	Interface	Application
RDHP-1423	2SC0106T	SCALE-2+	2	600 V and 1200 V	Any	N/A	Electrical (15 V logic)	General purpose drives, UPS, solar power and others

ORDERING INFORMATION

Part Number	Type Designation	Temp	SSD
2SC0106T	2SC0106T2A1-12	-40 °C to +85 °C	Yes

SCALE-2+ Gate Driver Core 2SC0115T

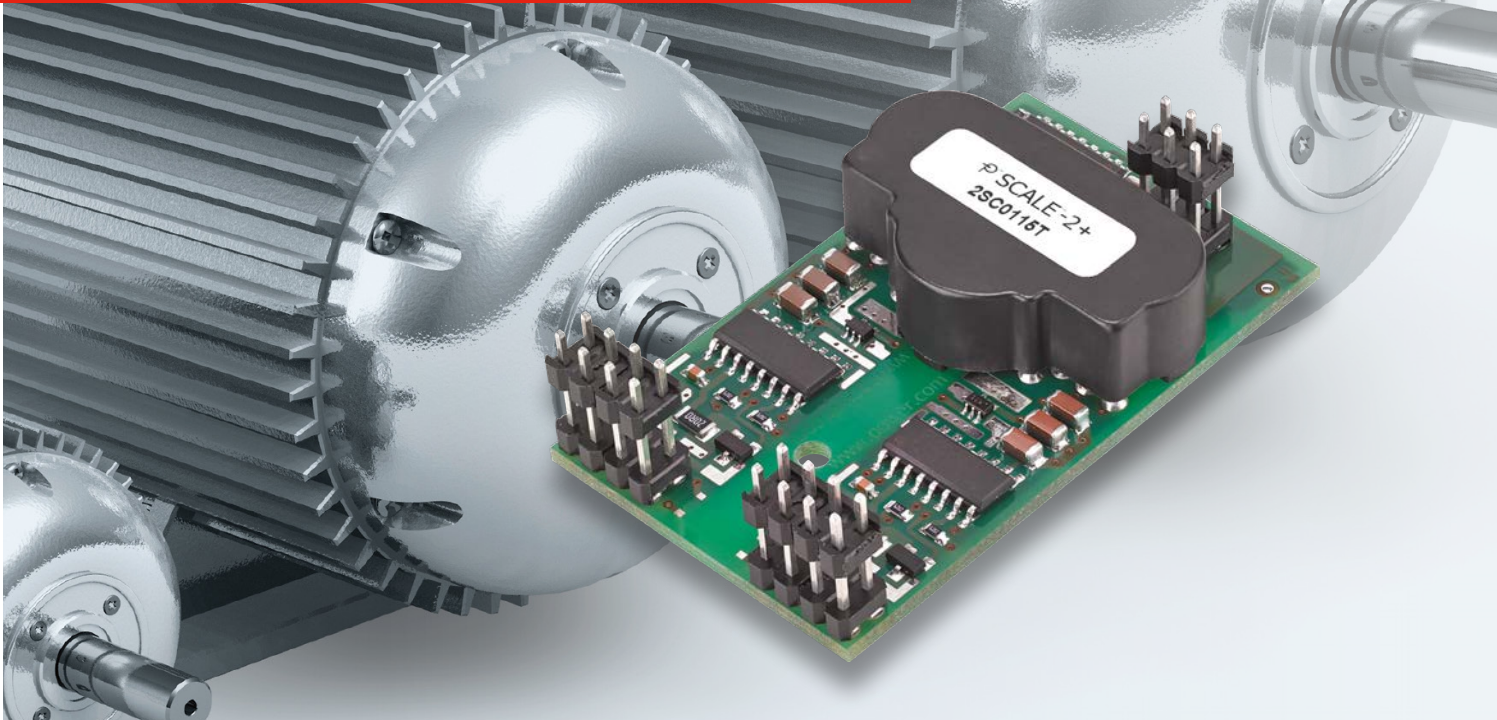

Dual-channel gate driver core – The alternative to optocoupler driver solutions for inverter designs in the 90 kW to 500 kW power range.

APPLICATIONS

- Industrial motor drives
- Premium drives
- Uninterruptible power supplies (UPS)
- Solar inverters
- Electro/hybrid drive vehicles
- Switch-mode power supplies (SMPS)
- Medical (MRT, CT, X-ray)
- Welding

CERTIFICATION

- Reinforced isolation according to VDE/EN and IEC

PRODUCT DESCRIPTION

The 2SC0115T combines a complete two-channel driver core with other driving components including isolated DC-DC converter, short-circuit protection, and supply voltage monitoring. Each channel is electrically isolated from the primary side and the other secondary channel. An output current of ± 15 A and 1.4 W drive power is available per channel. The driver provides a gate voltage swing for IGBT switching of +15 V/–6 V. Turn-on voltage is regulated to maintain a stable 15 V regardless of output power level. For SiC-MOSFET usage, the 2SC0115T provides adjustable gate source voltages. Outstanding EMC performance enables safe and reliable operation even in harsh environments.

KEY FEATURES

- Dual channel driver core for up to 1200 V
- Driver core for modules up to $V_{ces} \leq 1200$ V
- ± 15 A peak output gate current
- +15 V/–6 V gate output voltage
- 1 W @ 85 °C output power per channel or 1.4 W @ = 55 °C
- On-board power supply
- High reliability (reduced component count)
- Isolation technology according to international standard
- Short-circuit protection, undervoltage lockout
- <100 ns delay time up to 50 kHz
- Advanced Active Clamping (AAC)
- Able to drive SiC-MOSFETs

KEY DATA OVERVIEW

Parameter	Min	Typical	Max	Unit
Nominal supply voltage		15		V
Supply current @ $f_{IN}=0$ Hz		40		mA
Output power per channel		1	1.4	W
Gate voltage		+15/-6		V
Peak output current (gate current)	-15		+15	A
Switching frequency (f_s)	0		50	kHz
Duty cycle	0		100	%
Creepage distance primary-secondary	9			mm
Creepage distance secondary-secondary	5.5			mm
Clearance distance primary-secondary	9			mm
Clearance distance secondary-secondary	5.5			mm
Dielectric test voltage	4000			V_{AC}
Partial discharge extinction voltage	1800			V_{peak}
dv/dt immunity, input-to-output		50		kV/us
Operating temperature	-40		+105	$^{\circ}C$
Operating temperature	-40		+105	$^{\circ}C$

APPLICATION CIRCUIT (2SC0115T)

The 2SC0115T is a cost-effective driver core equipped with Power Integrations' latest SCALE-2+ chipset. The SCALE-2 chipset consists of two application specific integrated circuits (ASICs) that cover the main range of functions needed to design intelligent gate drivers. It comprises all functionality for an advanced dual-channel IGBT gate driver, including an isolated DC-DC converter, short-circuit protection, Advanced Active Clamping (AAC) and supply voltage monitoring.

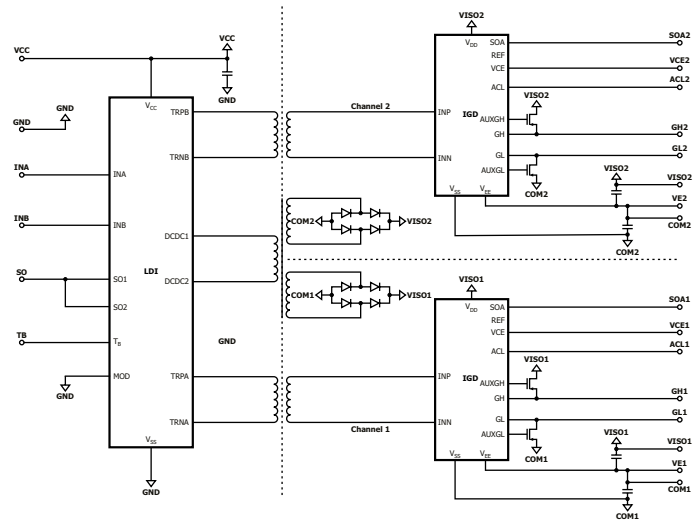

REFERENCE DESIGN

<https://gate-driver.power.com/design-support/reference-designs/>

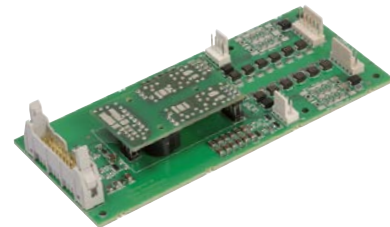

RDHP	Part Number	Technology	Channels	Voltage Class	Power Module Package	Related Power Module	Interface	Application
RDHP-1521	2SC0115T	SCALE-2+	2	600 V and 1200 V	Any	N/A	Electrical (15 V logic)	General purpose drives, UPS, solar power and others

ORDERING INFORMATION

Part Number	Type Designation	Temp	Pin Length
2SC0115T	2SC0115T2A0-12	-40 $^{\circ}C$ to +105 $^{\circ}C$, lead free, AAC	3.00 mm

SCALE-2+ Gate Driver Core 2SC0108T



Dual-channel, ultra-compact universal gate driver core for up to 1700 V IGBTs.

APPLICATIONS

- General purpose drives
- Uninterruptible power supplies (UPS)
- Solar and wind power converters
- Auxiliary converters for traction
- Electric/hybrid drive vehicles
- Switch-mode power supplies (SMPS)
- Medical (MRT, CT, X-ray)
- Laser technology
- Medium voltage drives

CERTIFICATION

- Reinforced isolation according to IEC 60664-1
- UL recognized: UL 508C NMMS2/8 and UL 60950-1 NWGQ2/8

KEY FEATURES

- Ultra-compact, dual-channel driver
- Blocking voltages up to 1700 V
- Switching frequency up to 50 kHz
- <100 ns delay time
- ±2 ns jitter
- ±8 A
- +15 V/-8 V gate driving
- Regulated gate emitter voltage
- Interface for 3.3 V – 15 V logic level
- Direct and half bridge modes
- Two-level and multi-level topologies
- IGBT short-circuit protection with Soft Shut Down (SSD)
- Isolated DC-DC converter
- 2 x 1 W output power
- Supply undervoltage lockout
- 45 mm x 34.3 mm footprint

KEY DATA OVERVIEW

Parameter	Min	Typical	Max	Unit
Nominal supply voltage		15		V
Supply current @ $f_{in}=0$ Hz		31		mA
Supply current, full load		240		mA
Output power per channel		1		W
Gate voltage		+15/-8		V
Peak output current (gate current)	-8		+8	A
Switching frequency (f_s)	0		50	kHz
Duty cycle	0		100	%
Turn-on delay		90		ns
Turn-off delay		75		ns
Output rise time		17		ns
Output fall time		15		ns
Creepage distance primary-secondary	12.9			mm
Creepage distance secondary-secondary	8.5			mm
Clearance distance primary-secondary	12.9			mm
Clearance distance secondary-secondary	6.5			mm
Dielectric test voltage	5000			V _{AC}
Partial discharge extinction voltage	1768			V _{peak}
dv/dt immunity, input-to-output			75	kV/us

APPLICATION CIRCUIT (2SC0108T)

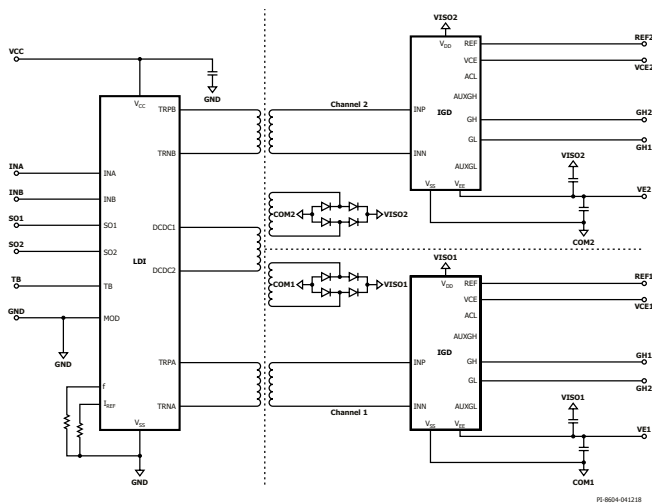

APPLICATION CIRCUIT (2SC0108T2D0-xx)

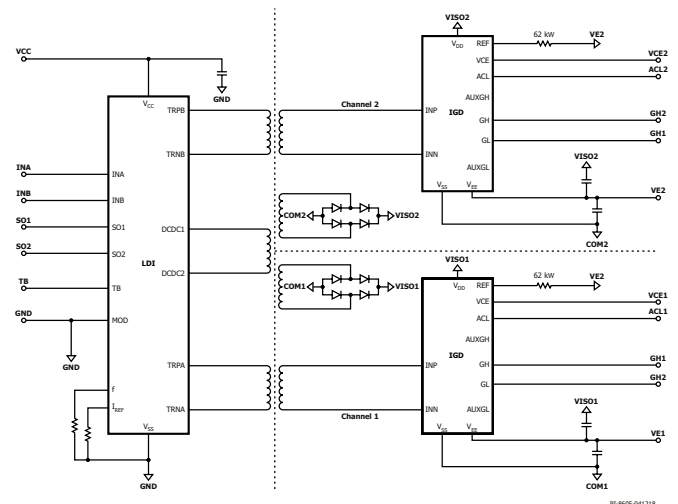

REFERENCE DESIGNS

<https://gate-driver.power.com/design-support/reference-designs/>

RDHP	Part Number	Technology	Channels	Voltage Class	Power Module Package	Related Power Module	Interface	Application
RDHP-1415	2SC0108T	SCALE-2+	2	600 V, 1200 V and 1700 V	Any	N/A	Electrical (15 V logic)	General purpose drives, UPS, solar power and others
RDHP-1531	2SC0108T	SCALE-2+	2	600 V, 1200 V and 1700 V	Any	N/A	Electrical (15 V logic)	General purpose drives, UPS, solar power and others

ORDERING INFORMATION

Part Number	Type Designation	Increased EMI Capability	Temp	Lead Free	Pin Length
2SC0108T	2SC0108T2D0-12	Yes	-40 °C to +85 °C	Yes	2.54 mm
	2SC0108T2H0-17	Yes	-40 °C to +85 °C	Yes	2.54 mm
	2SC0108T2F1-17	Yes	-40 °C to +85 °C	Yes	5.84 mm
	2SC0108T2G0-17	Yes	-40 °C to +85 °C	Yes	3.10 mm

SCALE-2+ Gate Driver Core 2SC0435T



Dual-channel, 1700 V gate driver core.

APPLICATIONS

- Wind power and photovoltaic
- Industrial drives
- Medium voltage drive
- Traction applications
- Electric/hybrid commercial vehicles
- Uninterruptible power supplies (UPS)
- Driving large parallel-connected IGBTs
- High gate current driving applications
- Medical (MRT, CT, X-ray)
- Industrial power supplies

CERTIFICATION

- Reinforced isolation according to IEC 60664-1
- UL recognized: UL 508C NMMS2/8 and UL 60950-1 NWGQ2/8

KEY FEATURES

- High power, dual-channel driver
- Blocking voltages up to 1700 V
- Switching frequency up to 100 kHz
- <100 ns delay time
- ±3 ns jitter
- ±35 A gate current @ 85 °C
- Regulated gate emitter voltage
- Interface for 3.3 V to 15 V logic level
- Direct and half bridge modes
- Two-level and multi-level topologies
- IGBT short-circuit protection
- Advanced Active Clamping
- Isolated DC-DC converter
- 2 x 4 W output power at 85 °C
- Supply undervoltage lockout
- 57.2 mm x 51.6 mm footprint

KEY DATA OVERVIEW

Parameter	Min	Typical	Max	Unit
Nominal supply voltage		15		V
Supply current @ $f_{in}=0$ Hz		58		mA
Supply current, full load		700		mA
Output power per channel		4		W
Gate voltage		+15/-10		V
Peak output current (gate current)	-35		+35	A
Switching frequency (f_s)	0		100	kHz
Duty cycle	0		100	%
Turn-on delay		85		ns
Turn-off delay		70		ns
Output rise time		20		ns
Output fall time		20		ns
Creepage distance primary-secondary	15.7			mm
Creepage distance secondary-secondary	12			mm
Clearance distance primary-secondary	15.7			mm
Clearance distance secondary-secondary	7.3			mm
Dielectric test voltage	5000			V _{AC}
Partial discharge extinction voltage	1768			V _{peak}
dv/dt immunity, input-to-output		50		kV/us
Operating temperature	-40		+85	°C

REFERENCE DESIGNS

<https://gate-driver.power.com/design-support/reference-designs/>



RDHP-1424



RDHP-1516



RDHP-1532

RDHP	Part Number	Technology	Channels	Voltage Class	Power Module Package	Related Power Module	Interface	Application
RDHP-1424	2SC0435T	SCALE-2+	2	1200 V and 1700 V	Dual 130 mm x 140 mm power modules	N/A	Electrical (15 V logic) or optical	Two-level topology for traction, solar power, general purpose drives and others
RDHP-1516 RDHP-1532	2SC0435T	SCALE-2+	2	600 V, 1200 V and 1700 V	Any	N/A	Electrical (15 V logic)	General purpose drives, traction, solar power and others

ORDERING INFORMATION

Part Number	Type Designation	Increased EMI Capability	Temp	Lead Free	Pin Length
2SC0435T	2SC0435T2F1-17	Yes	-40 °C to +85 °C	Yes	2.54 mm
	2SC0435T2G1-17	Yes	-40 °C to +85 °C	Yes	3.10 mm
	2SC0435T2H0-17	Yes	-40 °C to +85 °C	Yes	5.84 mm

SCALE-2 IGBT Gate Driver Core 2SD300C17



1700 V dual-channel gate driver core.

APPLICATIONS

- Traction
- Solar
- Wind power converters
- Medium voltage converters/drives
- Motor drives
- IGBTs up to 1700 V

CERTIFICATION

- Reinforced isolation according to IEC 60664-1

KEY FEATURES

- Dual-channel driver core
- Second source solution
- Blocking voltages up to 1700 V
- Switching frequency up to 60 kHz
- 400 ns pulse suppression
- <700 ns delay time
- ± 30 A gate current
- ± 15 V gate voltage
- 15 V logic interface
- Direct and half bridge modes
- IGBT short-circuit protection
- Soft Shut Down
- Isolated DC-DC converter
- 2 x 4 W output-power
- Supply undervoltage lockout

KEY DATA OVERVIEW

Parameter	Min	Typical	Max	Unit
Nominal supply voltage		15		V
Supply current @ $f_{in}=0$ Hz		65		mA
Supply current @ $f_{in}=60$ Hz		21		mA
Output power		4		W
Gate voltage		+15/-15		V
Peak output current (gate current)	-30		+30	A
Switching frequency (f_s) ¹⁾			60	kHz
Duty cycle	0		100	%
Turn-on delay		630		ns
Turn-off delay		490		ns
Operating temperature	-40		+85	°C

¹⁾ Maximum switching frequency depends on the IGBT gate charge. See data sheet for actual value of specific driver.

APPLICATION CIRCUIT (2SD300C17)

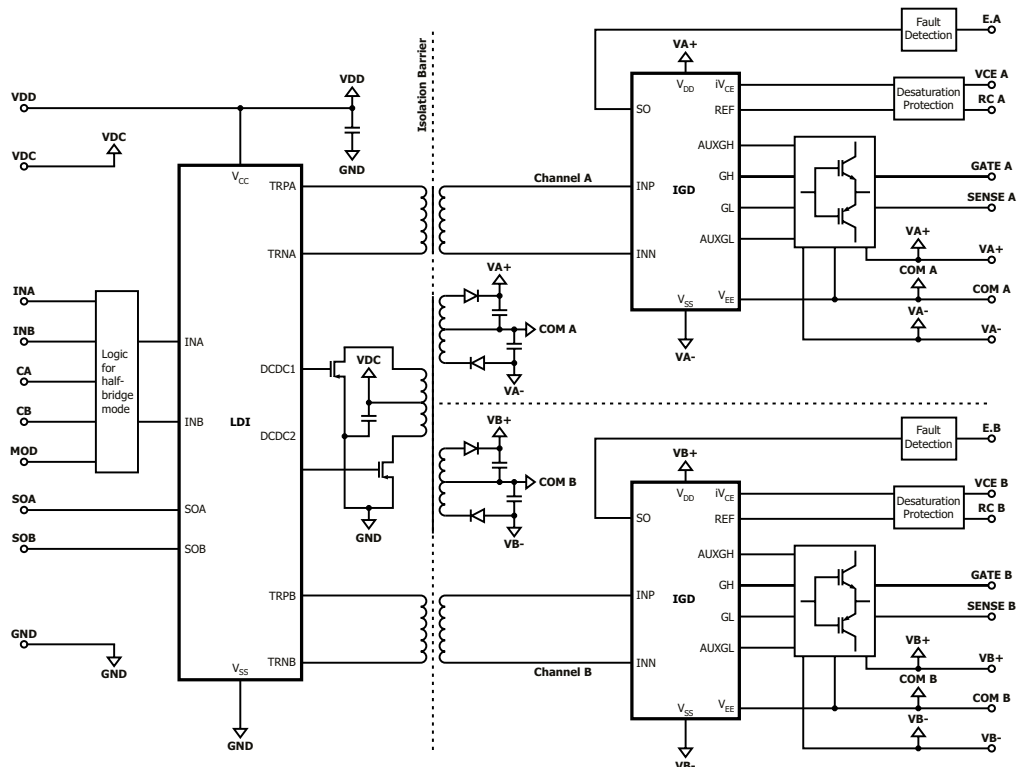

ORDERING INFORMATION

Part Number	Type Designation	Description	Lead Free
2SD300C17	2SD300C17A2	Standard version	Yes
	2SD300C17A3	Increased EMI capability	Yes

SCALE-2 Planar Gate Driver Core 2SC0650P

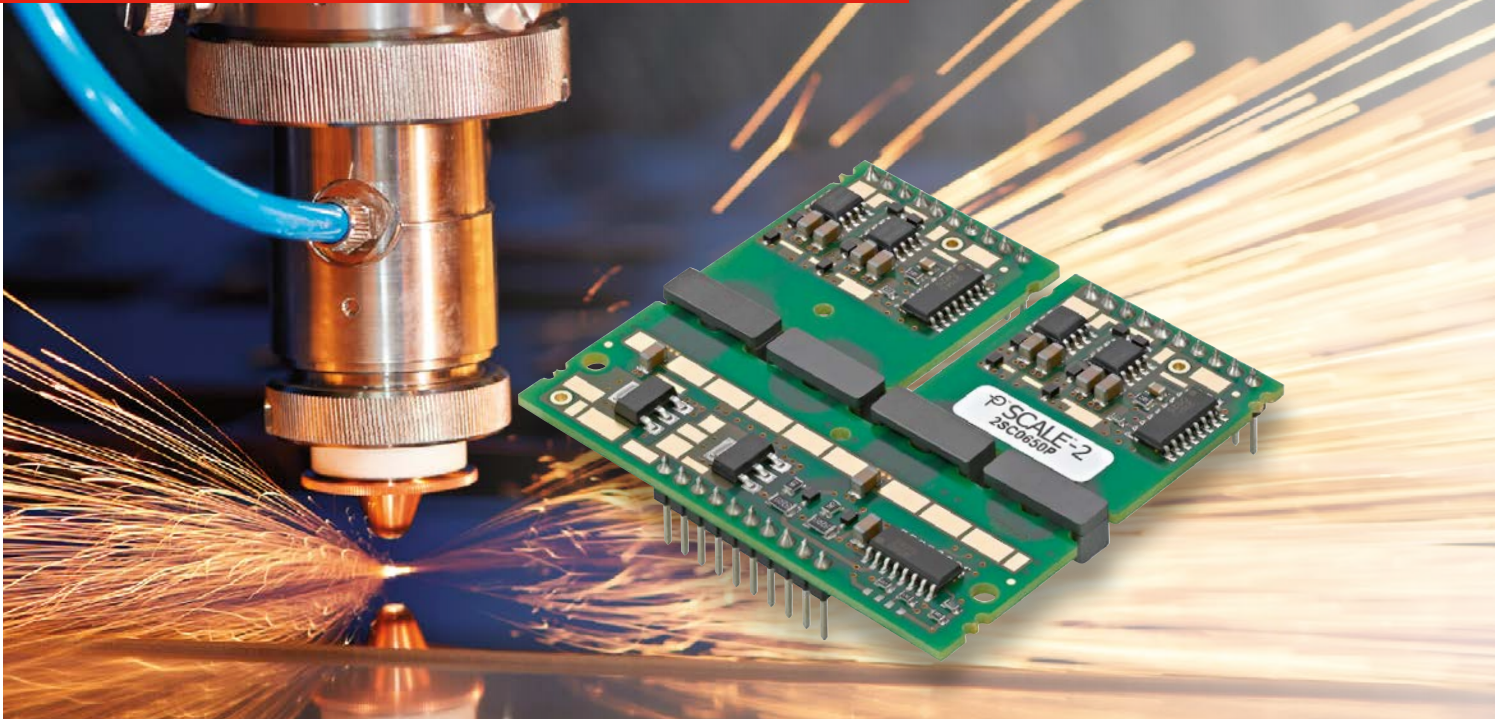

Dual-channel IGBT, MOSFET and SiC-MOSFET gate driver core with planar transformers.
Highest power density for high power and high frequency.
50 A gate current and 2 x 6 W output power at 85 °C ambient temperature.

APPLICATIONS

- High gate current driving applications
- High frequency applications
- Switch-mode power supplies (SMPS)
- Wind power converters
- Induction heating
- Industrial drives
- Traction applications
- Electro/hybrid commercial vehicles
- SiC-MOSFET applications

CERTIFICATION

- Reinforced isolation according to IEC 60664-1
- UL compliant

KEY FEATURES

- Ultra-low-profile solution
- Planar transformer isolation
- IGBT blocking voltages up to 1700 V
- Switching frequency up to 150 kHz
- ≤ 80 ns very short delay time
- $\leq \pm 2$ ns jitter
- ± 50 A gate current
- Compatible with all logic families
- IGBT short-circuit protection
- Advanced Active Clamping
- 2 x 6 W output power
- Supply undervoltage lockout

KEY DATA OVERVIEW

Parameter	Min	Typical	Max	Unit
Nominal supply voltage		15		V
Supply current @ $f_{IN}=0$ Hz		61		mA
Supply current, full load			1335	mA
Output power per channel			6.5	W
Gate voltage		+15/-10		V
Peak output current (gate current)	-50		+50	A
Switching frequency (f_s) ¹⁾			150	kHz
Duty cycle	0		100	%
Turn-on delay		80		ns
Turn-off delay		75		ns
Creepage distance primary-secondary		15		mm
Clearance distance primary-secondary		15		mm
Dielectric test voltage	5000		5100	V _{AC}
Partial discharge extinction voltage	1768			V _{peak}
dv/dt immunity, input-to-output			100	kV/us
Operating temperature	-40		+85	°C

¹⁾ Maximum switching frequency depends on the IGBT gate charge. See data sheet for actual value of specific driver.

APPLICATION CIRCUIT (2SC0650P)

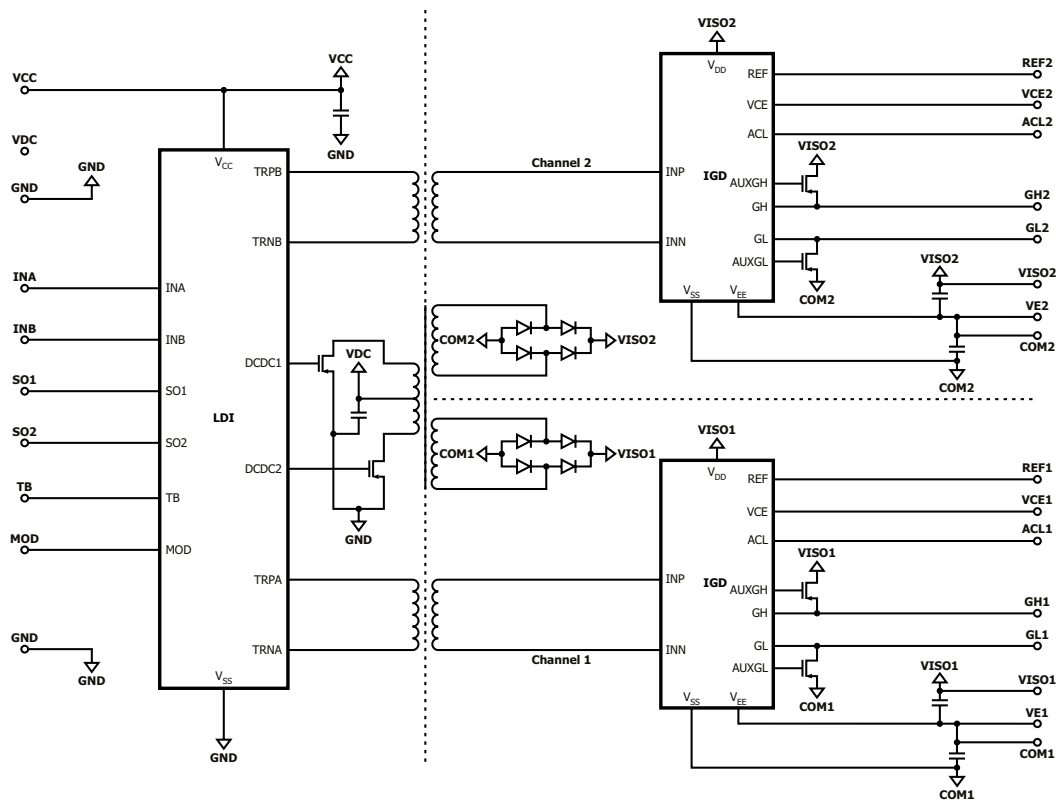

ORDERING INFORMATION

Part Number	Type Designation	Description	Temp	Lead Free	Pin Length
2SC0650P	2SC0650P2A0-17	Switching frequency up to 150 kHz	-40 °C to +85 °C	No	2.54 mm
	2SC0650P2C0-17	Switching frequency up to 150 kHz	-40 °C to +85 °C	No	5.84 mm

SCALE-2 Single-Channel Gate Driver Core 1SC2060P



Single-channel gate driver core with ± 60 A gate current for driving IGBT modules and SiC-MOSFET. 20 W output power for high frequency applications up to 500 kHz.

APPLICATIONS

- High frequency applications
- High gate current driving applications
- Switch-mode power supplies (SMPS)
- Driving parallel-connected large IGBTs
- Wind power converters
- Traction propulsion converters
- Industrial drives
- Induction heating
- SiC-MOSFET applications

CERTIFICATION

- Reinforced isolation according to IEC 60664-1
- UL compliant

KEY FEATURES

- Ultra-low-profile solution
- Planar transformer isolation
- Switching frequency up to 500 kHz
- IGBT blocking voltages up to 1700 V
- < 80 ns delay time
- $< \pm 1$ ns jitter
- ± 60 A gate current
- Compatible with all logic families
- IGBT short-circuit protection
- Advanced Active Clamping
- Isolated DC-DC converter
- 20 W output power
- Supply undervoltage lockout

KEY DATA OVERVIEW

Parameter	Min	Typical	Max	Unit
Nominal supply voltage		15		V
Supply current @ $f_{in}=0$ Hz		48		mA
Supply current, full load			2131	mA
Output power per channel			23	W
Gate voltage		+15/-10		V
Peak output current (gate current)	-60		+60	A
Switching frequency (f_s^1)			500	kHz
Duty cycle	0		100	%
Turn-on delay		75		ns
Turn-off delay		70		ns
Creepage distance primary-secondary	15			mm
Clearance distance primary-secondary	15			mm
Dielectric test voltage	5000	5050	5100	V_{AC}
Partial discharge extinction voltage	1768			V_{peak}
dv/dt immunity, input-to-output			100	kV/us
Operating temperature	-40		+85	$^{\circ}C$

¹⁾ Maximum switching frequency depends on the IGBT gate charge. See data sheet for actual value of specific driver.

APPLICATION CIRCUIT (1SC2060P)

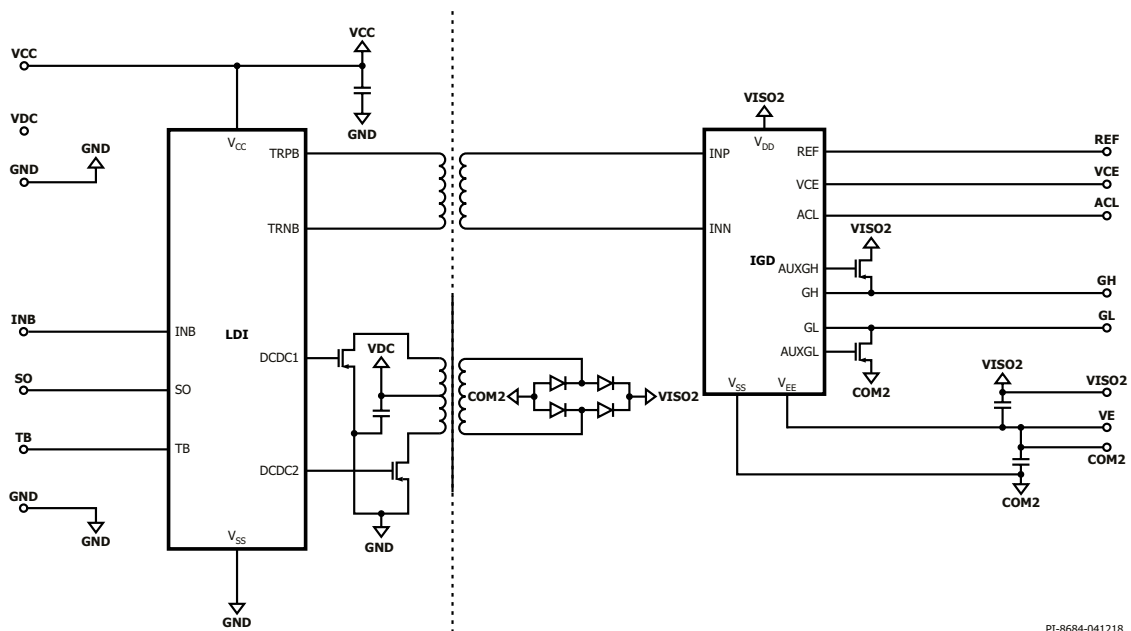

PI-9684-041218

ORDERING INFORMATION

Part Number	Type Designation	Description	Temp	Lead Free	Pin Length
1SC2060P	1SC2060P2A0-17	Switching frequency up to 500 kHz	-40 $^{\circ}C$ to +85 $^{\circ}C$	No	5.84 mm

SCALE-2 Gate Driver Core 2SC0535T



Dual-channel gate driver for 1.7 kV to 3.3 kV IGBTs and SiC MOSFETs.

APPLICATIONS

- Traction
- Railroad power supplies
- Light rail vehicles
- HVDC
- Flexible AC transmission systems (FACTS)
- Medium voltage converters
- Wind power converters
- Industrial drives

CERTIFICATION

- Reinforced isolation according to IEC 61800-5-1
- UL compliant

DRIVING PARALLEL-CONNECTED IGBTs

The driver allows direct parallel-connection of any of IGBT modules with individual drivers or a single gate driver. This concept for simple and reliable parallel connection makes it practical to set up a converter series with discrete modules as well as parallel-connected IGBTs.

KEY FEATURES

- IGBT blocking voltages up to 3300 V
- Two-level and multi-level topologies
- Applicable for SiC-MOSFETs
- Switching frequency up to 100 kHz
- <100 ns delay time
- ± 2 ns jitter
- ± 35 A current
- +15 V (regulated)/-10 V gate driving
- Interface for 3.3 V to 15 V logic level
- Direct and half bridge modes
- IGBT short-circuit protection
- Supply undervoltage lockout
- Isolated DC-DC converter
- 2 x 5 W output power
- Operating temperature -55 °C to +85 °C

KEY DATA OVERVIEW

Parameter	Min	Typical	Max	Unit
Nominal supply voltage		15		V
Supply current @ $f_{in}=0$ Hz		87		mA
Supply current, full load		900		mA
Output power per channel		5		W
Gate voltage		+15/-10		V
Peak output current (gate current)	-35		+35	A
Switching frequency (f_s) ¹⁾	0		100	kHz
Duty cycle	0		100	%
Turn-on delay		70		ns
Turn-off delay		70		ns
Output rise time		20		ns
Output fall time		20		ns
Creepage distance primary-secondary	44			mm
Creepage distance secondary-secondary	22			mm
Clearance distance primary-secondary	25			mm
Clearance distance secondary-secondary	14			mm
Dielectric test voltage	9100			V _{AC}
Partial discharge extinction voltage	4125			V _{peak}
dv/dt immunity, input-to-output		50		kV/us
Operating temperature	-55		+85	°C

¹⁾ Maximum switching frequency depends on the IGBT gate charge. See data sheet for actual value of specific driver.

APPLICATION CIRCUIT (2SC0535T)

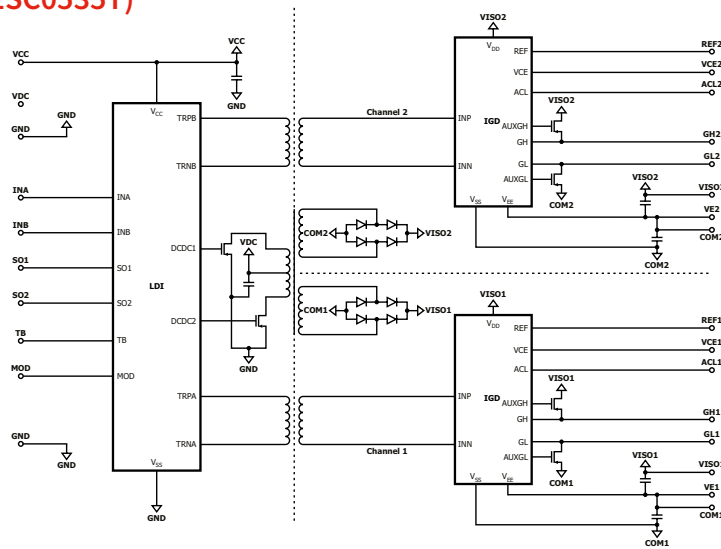

REFERENCE DESIGNS

<https://gate-driver.power.com/design-support/reference-designs/>



RDHP	Part Number	Technology	Channels	Voltage Class	Power Module Package	Related Power Module	Interface	Application
RDHP-1517	2SC0535T	SCALE-2	2	3300 V	Any	N/A	Electrical (15V logic)	General purpose drives, traction, wind power and others

ORDERING INFORMATION

Part Number	Type Designation	Description	Temp	Lead Free	Pin Length
2SC0535T	2SC0535T2A1-33	Standard version	-55 °C to +85 °C	Yes	5.84 mm
2SC0535T	2SC0535T2G0-33	Standard version	-55 °C to +85 °C	Yes	3.10 mm

SCALE-2 Gate Driver Core 2SC0635T

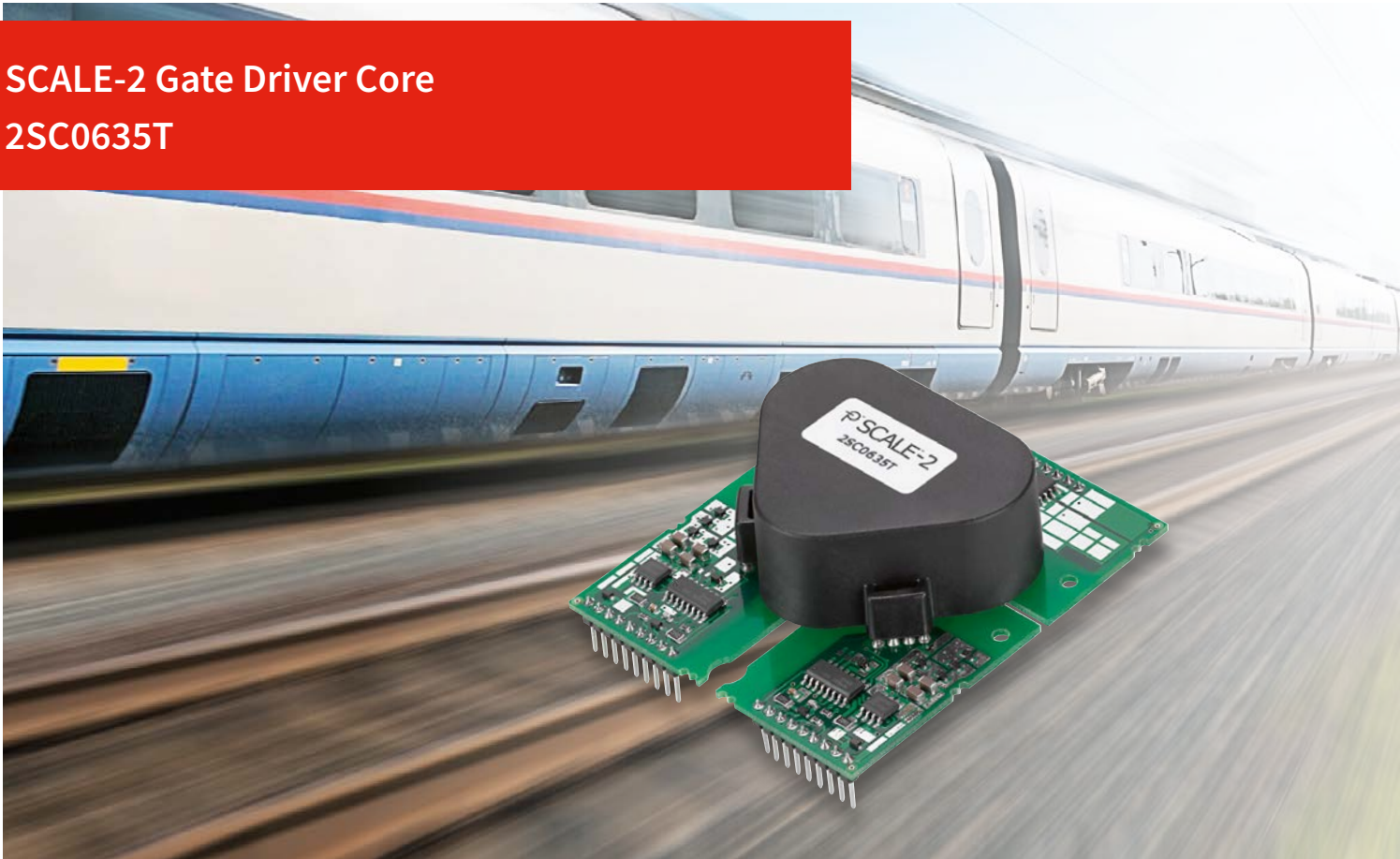

High-voltage, dual gate driver core with electrical signal interface.

APPLICATIONS

- Traction
- HVDC
- STATCOM
- Medium voltage converters/drives
- Wind power converters

CERTIFICATION

- Isolation coordination according to IEC 61800-5-1
- UL compliant

KEY FEATURES

- Dual-channel driver core for up to 4500 V
- ± 35 A gate current, +15 V/-10 V
- 6 W @ 85 °C per channel
- High reliability (reduced component count)
- Design flexibility
- 1700 V/3300 V three-level converters
- Direct paralleling capability
- Advanced Active Clamping
- Short-circuit protection, undervoltage lockout
- Adjustable short-circuit turn-off delay (three-level converters)
- <100 ns delay time
- Switching frequency up to 100 kHz

KEY DATA OVERVIEW

Parameter	Min	Typical	Max	Unit
Nominal supply voltage		15		V
Supply current @ $f_{in}=0$ Hz		95		mA
Supply current, full load			1484	mA
Output power per channel			9	W
Gate voltage		+15/-10		V
Peak output current (gate current)	-35		+35	A
Switching frequency (f_s) ¹⁾			100	kHz
Duty cycle	0		100	%
Turn-on delay		95		ns
Turn-off delay		80		ns
Creepage distance primary-secondary	34			mm
Clearance distance primary-secondary	25			mm
Dielectric test voltage		10300		V _{AC}
Partial discharge extinction voltage	5400			V _{peak}
dv/dt immunity, input-to-output			50	kV/us
Operating temperature	-40		+85	°C

¹⁾ Maximum switching frequency depends on the IGBT gate charge. See data sheet for actual value of specific driver.

APPLICATION CIRCUIT (2SC0635T)

The 2SC0635T2A0-45 combines a complete two-channel driver core with all components required for driving, such as an isolated DC-DC converter, short-circuit protection, Advanced Active Clamping, as well as supply voltage monitoring. Each of the two output channels is electrically isolated from the primary side and from the other secondary channel.

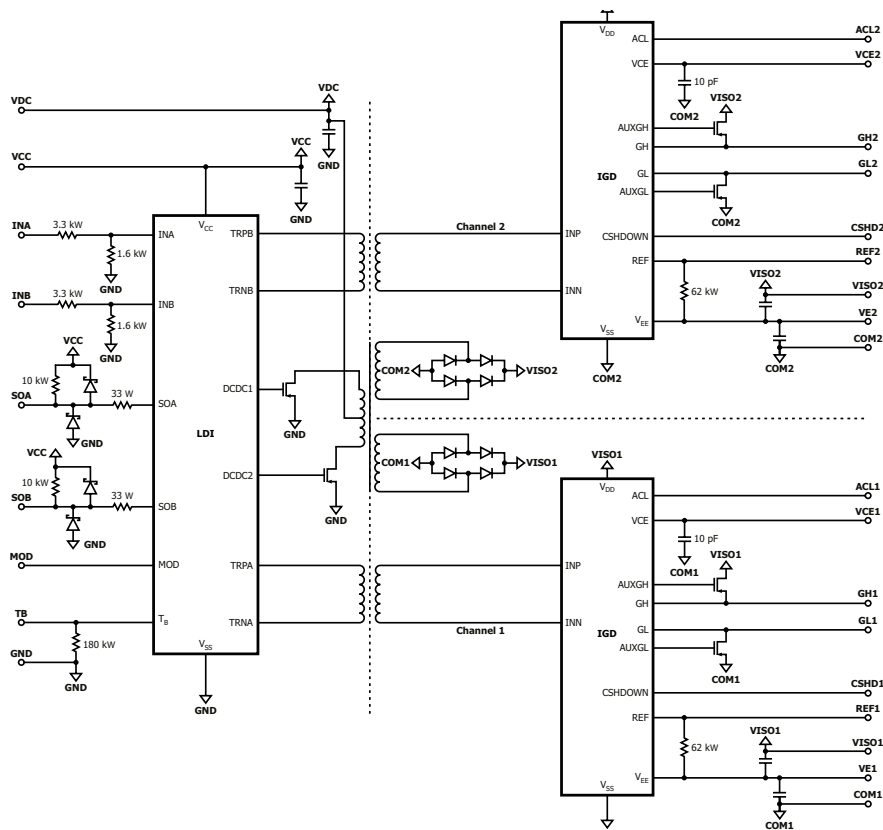

ORDERING INFORMATION

Part Number	Type Designation	Description	Temp	Lead Free	Pin Length
2SC0635T	2SC0635T2A1-45	For 4.5 kV IGBT modules, electrical interface	-40 °C to +85 °C	Yes	3.1 mm

SCALE-2 IGBT Gate Driver Core 1SC0450V2, 1SC0450E2



High-voltage 4.5 kV and 6.5 kV single-channel gate driver with integrated DC-DC converter.

APPLICATIONS

- Traction
- HVDC
- STATCOM
- Medium voltage converters/drives
- Wind power converters

CERTIFICATION

- Isolation according to IEC 61800-5-1
- UL compliant

KEY FEATURES

- Single-channel driver core for up to 4.5 kV and 6.5 kV IGBTs
- ± 50 A gate current, +15 V/-10 V
- 6 W @ 85 °C
- High reliability (reduced component count)
- Parallel connection of IGBT modules
- Design flexibility
- Advanced Active Clamping and Dynamic Advanced Active Clamping
- Short-circuit protection, undervoltage lockout
- <100 ns delay time
- Power supply short-circuit protection
- Lead free
- -40 °C to +85 °C

KEY DATA OVERVIEW

Parameter	Min	Typical	Max	Unit
Nominal supply voltage		15		V
Supply current @ $f_{in}=0$ Hz		130		mA
Supply current, full load			880	mA
Output power per channel			8	W
Gate voltage		+15/-10		V
Peak output current (gate current)	-50		+50	A
Switching frequency (f_s ¹)			10	kHz
Duty cycle	0		100	%
Turn-on delay		135		ns
Turn-off delay		105		ns
Creepage distance primary-secondary	45			mm
Clearance distance primary-secondary	25			mm
Dielectric test voltage		10300		V _{AC}
Partial discharge extinction voltage	5400/7800			V _{peak}
dv/dt immunity, input-to-output			35	kV/us
Operating temperature	-40		+85	°C
Dielectric test voltage	9100			V _{AC}
Partial discharge extinction voltage	4125			V _{peak}
dv/dt immunity, input-to-output		50		kV/us
Operating temperature	-55		+85	°C

¹ Maximum switching frequency depends on the IGBT gate charge. See data sheet for actual value of specific driver.

APPLICATION CIRCUIT (1SC0450V)

APPLICATION CIRCUIT (1SC0450E)

The 1SC0450V2A0-xx combines a complete single-channel driver core with all components required for driving, such as an isolated DC-DC converter, short-circuit protection, Advanced Active Clamping, as well as supply voltage monitoring. Enhanced features, such as gate boosting or power supply short-circuit protection, are also implemented and provide further driving benefits.

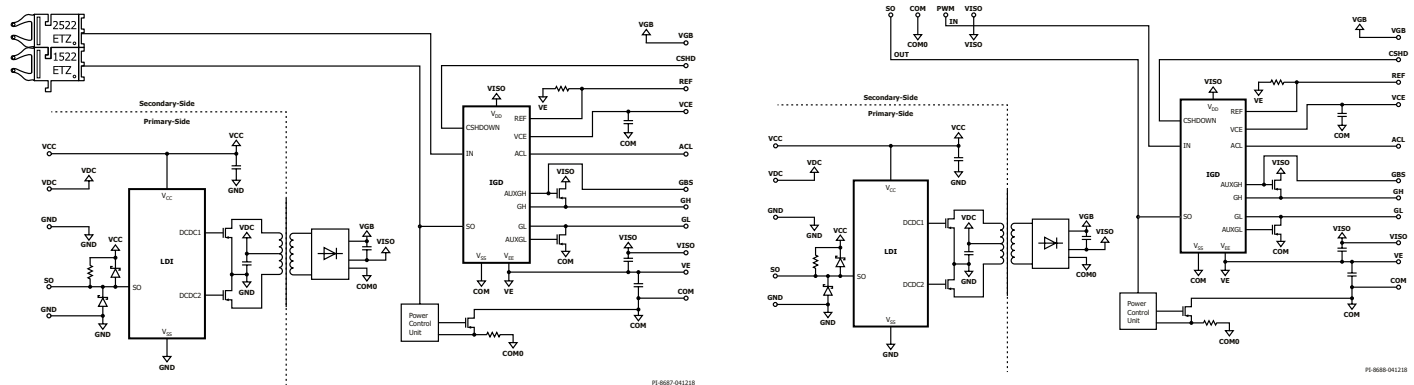

REFERENCE DESIGN

<https://gate-driver.power.com/design-support/reference-designs/>



RDHP	Part Number	Technology	Channels	Voltage Class	Power Module Package	Related Power Module	Interface	Application
RDHP-1413	1SC0450E	SCALE-2	1	4500 V	Press-pack IGBTs	N/A	Optical	Two-level and multi-level topologies for medium voltage drives, FACTS and others

ORDERING INFORMATION

Part Number	Type Designation	Description	Temp	Lead Free	Pin Length
1SC0450	1SC0450V2B0-45	Fiber optic interface	-40 °C to +85 °C	Yes	5.84 mm
	1SC0450V2B0-65	Fiber optic interface	-40 °C to +85 °C	Yes	5.84 mm
	1SC0450E2B0-45	Non-isolated electrical interface	-40 °C to +85 °C	Yes	5.84 mm
	1SC0450E2B0-65	Non-isolated electrical interface	-40 °C to +85 °C	Yes	5.84 mm

Plug-and-Play Gate Drivers INTRODUCTION

Power Integrations is a technology and market leader in mid- and high-power gate drivers. Using highly integrated technology, the company's gate drivers employ 85% fewer components than other commonly-available solutions. Power Integrations has 30 years' history of supporting demanding industries such as traction, power generation, power transmission and industrial automation with products that combine outstanding reliability, best-in-class performance and competitive pricing.

INNOVATIVE TECHNOLOGY

Power Integrations pioneered the use of ASIC technology to develop highly-integrated, ultra-efficient, high-performance gate drivers. Our SCALE-2 design methodology uses an ASIC chipset to reduce component count and save space. It is manufactured on an automotive-qualified BiCMOS wafer processing line, so performance and reliability are ensured. By owning the IC design, Power Integrations is also able to insure a long service life.

COMPLETE AND READY TO USE

Plug-and-play products are complete, ready-to-use IGBT gate drivers that have been tightly matched to a specific IGBT module. Drivers are available to cover a large selection of high-power and high-voltage IGBT modules with reverse blocking voltages from 600 V to 6500 V. All plug-and-play drivers are equipped with DC-DC converters, short-circuit protection, active clamping, supply monitoring, soft start and more.

DESIGN SUPPORT AND CUSTOMISATION

Power Integrations develops reference designs and semi-custom gate drive designs based on the company's driver cores and produces full custom drivers using the company's SCALE-2 platform for large projects.



SCALE-2 PLUG-AND-PLAY GATE DRIVER

IGBT Module Blocking Voltage

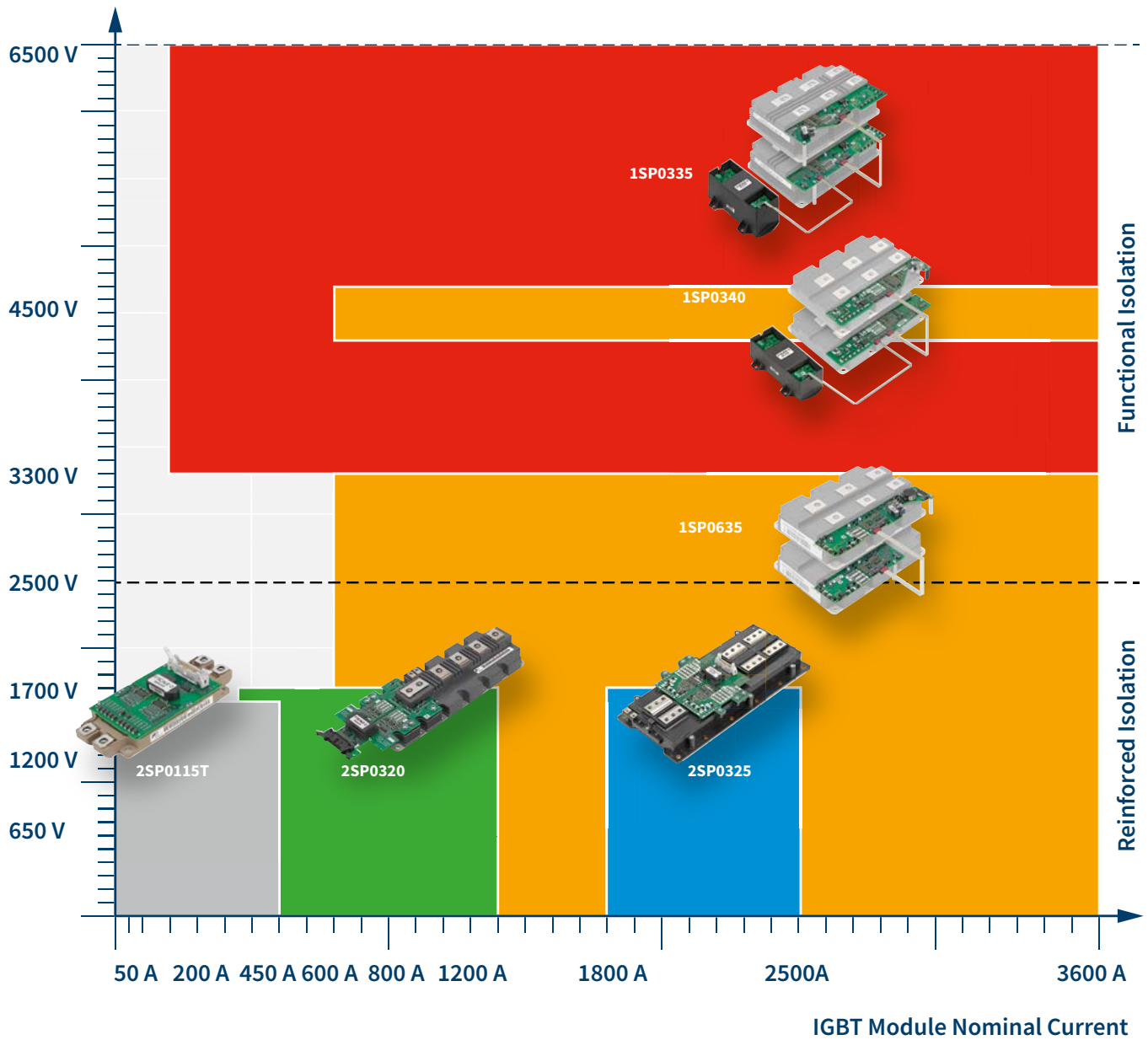

SCALE-2 Plug-and-Play Gate Driver 2SP0115T



Dual-channel gate driver with electrical interface for 17 mm dual IGBT modules.

APPLICATIONS

- Wind power converters
- Industrial drives
- Railways auxiliary systems
- Induction heating
- Elevators
- UPS and SMPS
- Medical (MRT, CT, X-ray)
- Laser technology

CERTIFICATION

- Isolation according to IEC 60664-1
- UL compliant

KEY FEATURES

- <100 ns delay time
- ± 4 ns jitter
- +15 V (regulated)/-8 V gate driving
- Separate gate current paths (on/off)
- Suitable for IGBTs up to 1700 V
- Interface for 3.3 V to 15 V logic level
- Direct and half bridge modes
- Two-level and multi-level topologies
- IGBT short-circuit protection
- Advanced Active Clamping
- Isolated DC-DC converter
- 2 x 1 W output power
- Supply undervoltage lockout
- Superior EMC
- Reliable, long service life

KEY DATA OVERVIEW

Parameter	Min	Typical	Max	Unit
Nominal supply voltage		15		V
Supply current @ $f_{in}=0$ Hz		33		mA
Supply current, full load			220	mA
Output power per channel		1		W
Gate voltage		+15/-8		V
Peak output current (gate current)	-8		+15	A
Switching frequency (f_s) ¹⁾	0		50	kHz
Duty cycle	0		100	%
Turn-on delay		75		ns
Turn-off delay		65		ns
Creepage distance primary-secondary	12.6			mm
Creepage distance secondary-secondary	6.6			mm
Clearance distance primary-secondary	12.3			mm
Clearance distance secondary-secondary	6.6			mm
Dielectric test voltage (600 V/1200 V versions)	3800			V _{AC}
Dielectric test voltage (1700 V version)	5000			V _{AC}
Partial discharge extinction voltage (600/1200 V versions)	1200			V _{peak}
Partial discharge extinction voltage (1700 V version)	1700			V _{peak}
dv/dt immunity, input-to-output		50		kV/us
Operating temperature 2SP0115T2Ax-xx	-20		+85	°C
Operating temperature 2SP0115T2Bx-xx	-40		+85	°C

ELECTRICAL INTERFACE DIC20

The 2SP0115T driver series is equipped with DIC20 electrical interface, fully compatible to PrimePACK driver series 2SP0320T.

The DIC20 electrical interface is very simple and easy to use. It has the following terminals:

- Power supply and GND
- 2x drive signal inputs
- 2x status outputs (failure returns)
- 1x mode selection (half bridge mode/direct mode)
- 1x input to set the blocking time

All inputs are ESD protected and all digital inputs have Schmitt trigger characteristics.

PrimePACK™ is a registered trademark of Infineon Technology AG

¹⁾ Maximum switching frequency depends on the IGBT gate charge. See data sheet for actual value of specific driver.

PLUG-AND-PLAY GATE DRIVER

The driver contains all necessary components for optimal and safe driving of the relevant IGBT module: smallest gate resistors in order to minimize switching losses, gate clamping, active clamping diodes (overvoltage protection at turn-off), V_{ce} monitoring (short-circuit protection), as well as the input electrical connector X1. Moreover, it includes components for setting the turn-off trip level, the response time and the dead time between both channels in half bridge mode. Its plug-and-play capability means that it is ready to operate immediately after mounting. The user needs to invest no effort in designing or adjusting the driver for a specific application.

APPLICATION CIRCUIT (2SP0115T)

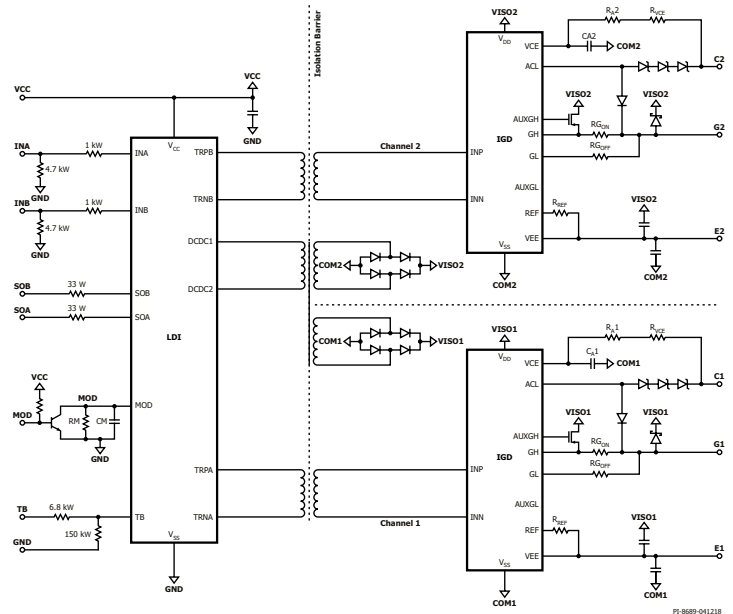

ORDERING INFORMATION

Part Number	Type Designation	Description
2SP0115T	2SP0115T2A0	Standard version (-20 °C to +85 °C)
	2SP0115T2B0	Extended operating temperature (-40 °C to +85 °C)
	2SP0115T2A0-xx or	xx: voltage basic type (for any module type) ¹⁾
	2SP0115T2B0-xx	xx = 06 (600 V) / xx = 12 (1200 V) / xx = 17 (1700 V)
		xx: specific module type (Infineon, Fuji, Mitsubishi, Starpower, Powerex) such as 2MBI300VN-120-50
	2SP0115T2C0-xx	xx: voltage basic type xx = 06 (600 V) / xx = 12 (1200 V) / xx = 17 (1700 V) 15 V logic level, extended operating temperature (-40 °C to +85 °C)

¹⁾ Gate resistors have to be soldered by customer

SCALE-2 Plug-and-Play IGBT Gate Driver 2SP0320T2, 2SP0320V2

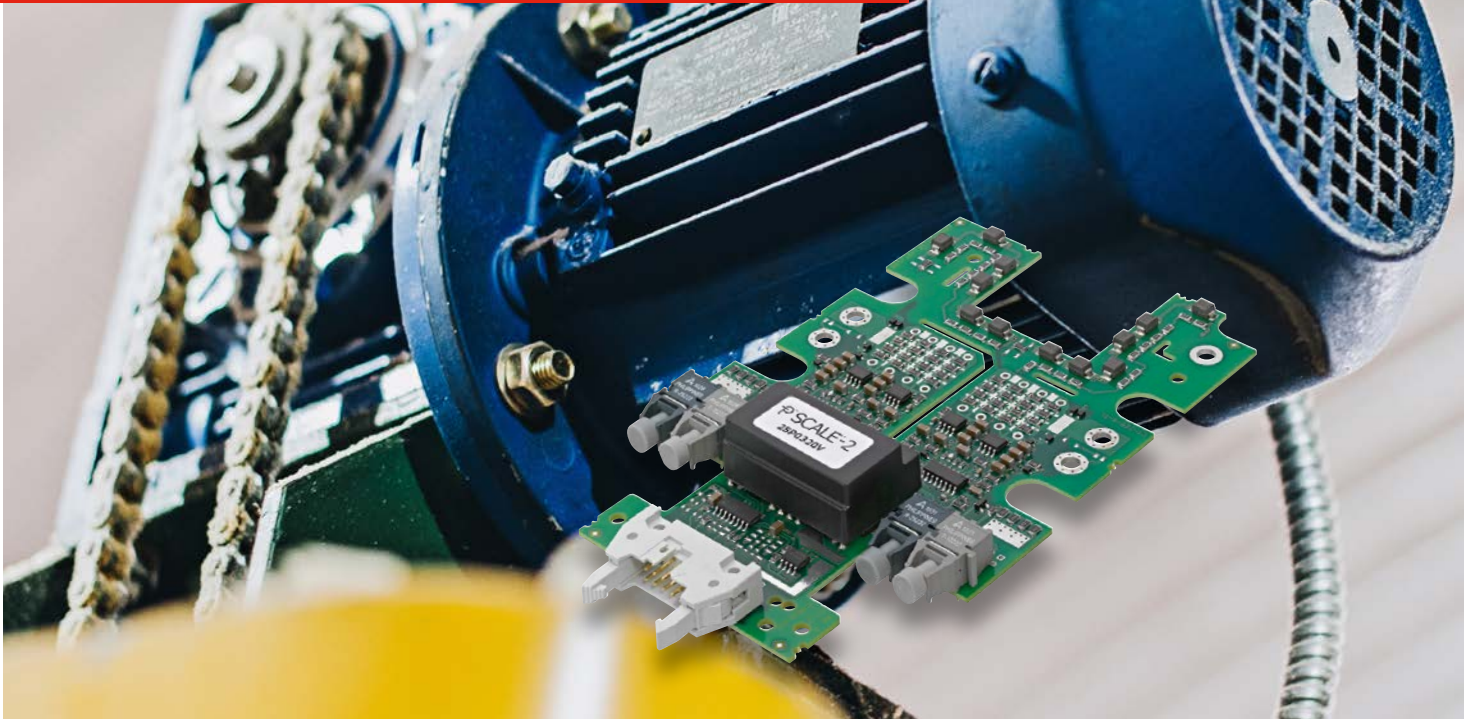

Dual-channel gate driver for PrimePACK and equivalent IGBT modules with electrical or fiberoptic interfaces.

APPLICATIONS

- Wind power converters
- Industrial drives
- Railway auxiliary systems
- Induction heating
- Elevators
- UPS and SMPS
- Medical (MRT, CT, X-ray)
- Laser technology

CERTIFICATION

- Reinforced isolation to IEC-60664-1
- UL compliant

KEY FEATURES

- Compact plug-and-play solution up to 1.7 kV
- <120 ns delay time
- ± 2 ns jitter
- Interface for 3.3 V to 15 V logic level
- Electrical or fiberoptic interfaces
- +15 V/-10 V gate driving
- Easy mounting directly onto the IGBT
- Supports two-level and three-level converter topologies
- IGBT short-circuit protection
- Advanced Active Clamping
- Isolated DC-DC converter
- Supply undervoltage lockout

KEY DATA OVERVIEW

Parameter	Min	Typical	Max	Unit
Nominal supply voltage		15		V
Supply current 2SP0320T2xx @ $f_{IN}=0$ Hz		56		mA
Supply current 2SP0320V2xx and 2SP0320S2xx @ $f_{IN}=0$ Hz		164		mA
Supply current, full load 2SP0320T2xx		600		mA
Supply current, full load 2SP0320V2xx and 2SP0320S2xx		690		mA
Output power per channel		3		W
Gate voltage		+15/-10		V
Peak output current (gate current)	-20		+20	A
Switching frequency (f_s^{-1})	0		30	kHz
Duty cycle	0		100	%
Turn-on delay, 2SP0320T2xx		90		ns
Turn-off delay, 2SP0320T2xx		90		ns
Turn-on delay, 2SP0320V2xx and 2SP0320S2xx		120		ns
Turn-off delay, 2SP0320V2xx and 2SP0320S2xx		100		ns
Creepage distance primary-secondary	20			mm
Creepage distance secondary-secondary	17			mm
Dielectric test voltage	5000			VAC
Partial discharge extinction voltage	1768			V _{peak}
dv/dt immunity, input-to-output			50	kV/us
Operating temperature	-40		+85	°C

¹⁾ Maximum switching frequency depends on the IGBT gate charge. See data sheet for actual value of specific driver.

APPLICATION CIRCUIT (2SP0320V2)

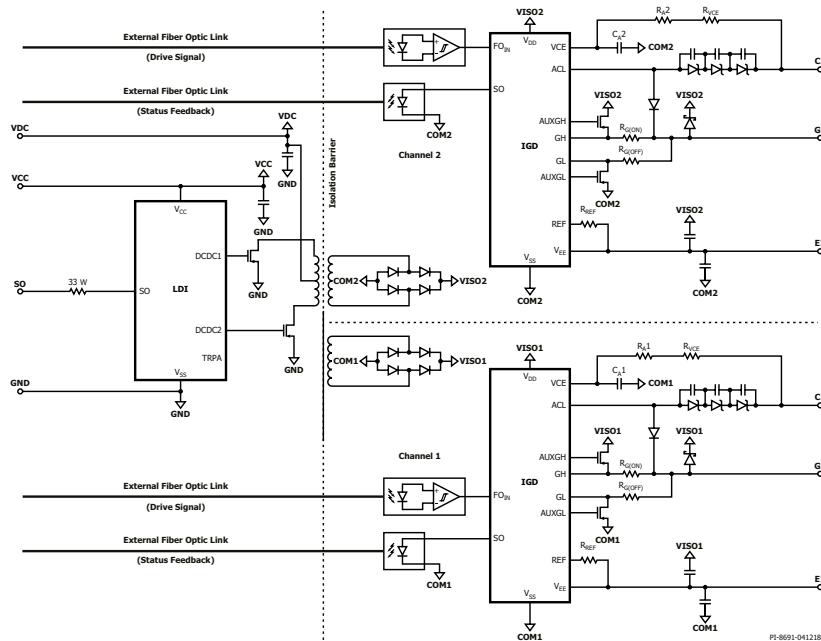

ORDERING INFORMATION

	2SP0320T2	2SP0320V2
Type designation	2SP0320T2A0-xx 2SP0320T2C0-12 2SP0320T2C0-17	2SP0320V2A0-xx
xx: Voltage basic type ¹ or xx: Specific module type	xx = 12 (1200 V) / xx = 17 (1700 V) xx = e.g., 2MBI900VXA-120E-50	
Input signal interface	Electrical interface 2SP0320T2A0: 3.3-15 V logic level 2SP0320T2C0: 15 V logic level	Versatile FOL input/output
On-board connector	DIC20 ²	HFBR 2522ETZ/1522ETZ

1) Gate resistors must be soldered by customer

2) Electrical connector on the driver: 71922-120LF from FCI, recommended cable connector: 71600-020LF from FCI. Recommended twisted pair flat cable: 1700/20 or 2100/20 from 3M™.

SCALE-2 Plug-and-Play IGBT Gate Driver 2SP0325V2, 2SP0325T2



Perfect driving of the new mega-power dual (nMPD) from Mitsubishi.

APPLICATIONS

- Wind power converters
- Solar inverters
- UPS systems
- Industrial drives

CERTIFICATION

- Creepage and clearance according to IEC 60664-1
- UL compliant

PLUG-AND-PLAY GATE DRIVER

The driver contains all necessary components for optimal and safe driving of the relevant IGBT module: smallest gate resistors in order to minimize switching losses, gate clamping, active clamping diodes (overvoltage protection at turn-off), V_{ce} monitoring (short-circuit protection), as well as the input electrical connector X1. Moreover, it includes components for setting the turn-off trip level, the response time and the dead time between both channels in half bridge mode. Plug-and-play capability means that this driver is ready to operate immediately after mounting. The user needs to invest no effort in designing or adjusting the driver to a specific application.

KEY FEATURES

- High-power dual-channel plug-and-play IGBT gate driver
- Schmitt trigger input
- 15 V Electrical logic level or fiberoptic interfaces
- +15 V (regulated)/-10 V gate driving
- Supports three-level converter topologies
- IGBT short-circuit protection
- Isolated DC-DC converter
- Supply undervoltage lockout
- Dynamic Advanced Active Clamping (DAAC)

KEY DATA OVERVIEW

Parameter	Min	Typical	Max	Unit
Nominal supply voltage		15		V
Supply current @ $f_{IN}=0$ Hz		55		mA
Supply current, full load			573	mA
Output power per channel			2	W
Gate voltage		+15/-10		V
Peak output current (gate current)	-25		+25	A
Switching frequency (f_s) ¹⁾			5	kHz
Duty cycle	0		100	%
Turn-on delay		80		ns
Turn-off delay		65		ns
Creepage distance primary-secondary	12.5			mm
Clearance distance primary-secondary	12.5			mm
Dielectric test voltage		5050		V _{AC}
Partial discharge extinction voltage	1768			V _{peak}
dv/dt immunity, input-to-output			50	kV/us

¹⁾ Maximum switching frequency depends on the IGBT gate charge. See data sheet for actual value of specific driver.

APPLICATION CIRCUIT (2SP0325T)

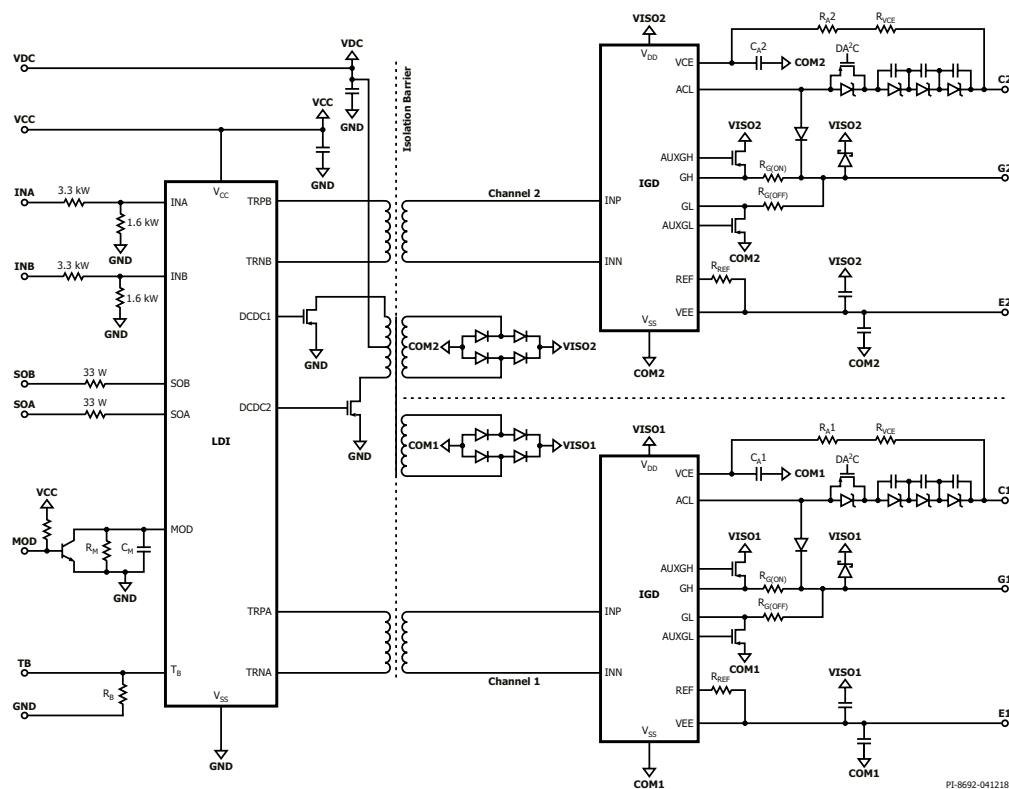

ORDERING INFORMATION

Part Number	Type Designation	Description	Lead Free
2SP0325T	2SP0325T2A0	Electrical interface	Yes
2SP0325V	2SP0325V2A0	Fiber optic interface with built-in DC-DC power supply	Yes

SCALE-2 Plug-and-Play IGBT Gate Driver 1SP0635V2



Single-channel plug-and-play gate driver 1.2 kV, 1.7 kV and 3.3 kV, supports direct paralleling with master/slave principle.

APPLICATIONS

- Traction
- Railroad power supplies
- Light rail vehicles
- HVDC
- Flexible AC transmission systems
- Medium voltage converters
- Industrial drives
- Wind power converters

CERTIFICATION

- Creepage and clearances according to IEC 60077-1
- UL compliant

KEY FEATURES

- Single-channel driver
- Compact plug-and-play solution
- Fiberoptic interfaces
- +15 V/-10 V gate driving
- Regulated gate voltage
- Direct paralleling of IGBTs
- Two-level and multi-level topologies
- Embedded paralleling capability
- IGBT short-circuit protection
- Dynamic Advanced Active Clamping (DAAC)
- Built-in isolated DC-DC converter
- Supply undervoltage lockout
- Easy mounting directly onto the IGBT
- Extremely reliable, long service life

KEY DATA OVERVIEW

Parameter	Min	Typical	Max	Unit
Nominal supply voltage		15		V
Supply current 1SP0635x2Mx @ $f_{IN}=0$ Hz		120		mA
Per additional 1SP0635D2Sx @ $f_{IN}=0$ Hz		35		mA
Supply current, full load 1SP0635x2Mx		325		mA
Output power (1SP0635V2Mx or 1SP0635SMx)		3		W
Output power (1SP0635D2Sx)		2.6		W
Gate voltage		+15/-10		V
Peak output current (gate current)	-35		+35	A
Switching frequency (f_s^{-1})	0		30	kHz
Duty cycle	0		100	%
Turn-on delay		190		ns
Turn-off delay		185		ns
Creepage distance primary-secondary	21			mm
Clearance distance primary-secondary	21			mm
Dielectric test voltage (3.3 kV versions)	6000			V _{AC}
Partial discharge extinction voltage (3.3 kV versions)	3630			V _{peak}
Operating temperature	-40		+85	°C

¹⁾ Maximum switching frequency depends on the IGBT gate charge. See data sheet for actual value of specific driver.

1SP0635 SERIES MASTER-SLAVE SYSTEM

The master (1SP0635V or 1SP0635S) can be used as perfect stand-alone driver without a slave to drive IGBT modules without parallel connection or with one to three 1SP0635D slaves to drive up to four parallel-connected IGBT modules. Paralleling is achieved by simply connecting the master and slaves via the provided paralleling interfaces X2 and X3, which are identical.

APPLICATION CIRCUIT (1SP0635)

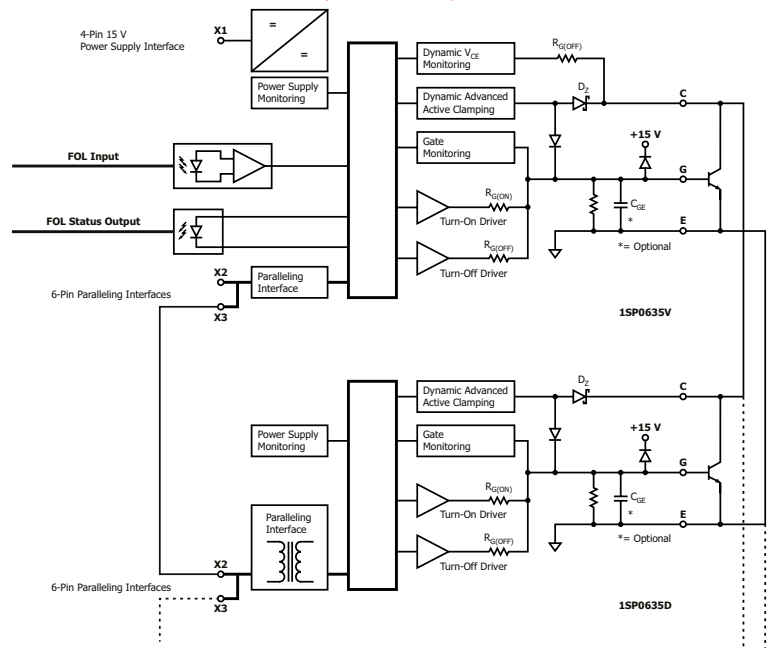

ORDERING INFORMATION

	V-Type (Master)	S-Type (Master)	D-Type (Slave)
Type designation plus	1SP0635V2M1-xx	1SP0635S2M1-xx	1SP0635D2S1-xx
xx: Voltage basic type	xx = 12 (1200 V) xx = 17 (1700 V) xx = 33 (3300 V)		
or xx: Specific module type	e.g., 5SNA1200E330100		
Module package	IHM 130/190		
Input signal interface	Versatile FOL input/output	ST FOL input/output	N/A
On-board connector	HFBR-1522ETZ/2522ETZ	HFBR1412Z/2412Z	N/A
Bus interface	X2/X3		
On-board connector	MBCON-6-1-0		
Connecting cable	MBC61-xxx-0 (xxx=030,050,070,110)		
Power supply	X1		N/A
User-board connector	Right angle MBCON-4-1-0; vertical MBCON-4-2-0		N/A
Connecting cable	MBC41-xxx-0 (xxx=035,045,070)		N/A

SCALE-2 Plug-and-Play IGBT Gate Driver 1SP0340V2 and DC-DC Converter ISO5125I

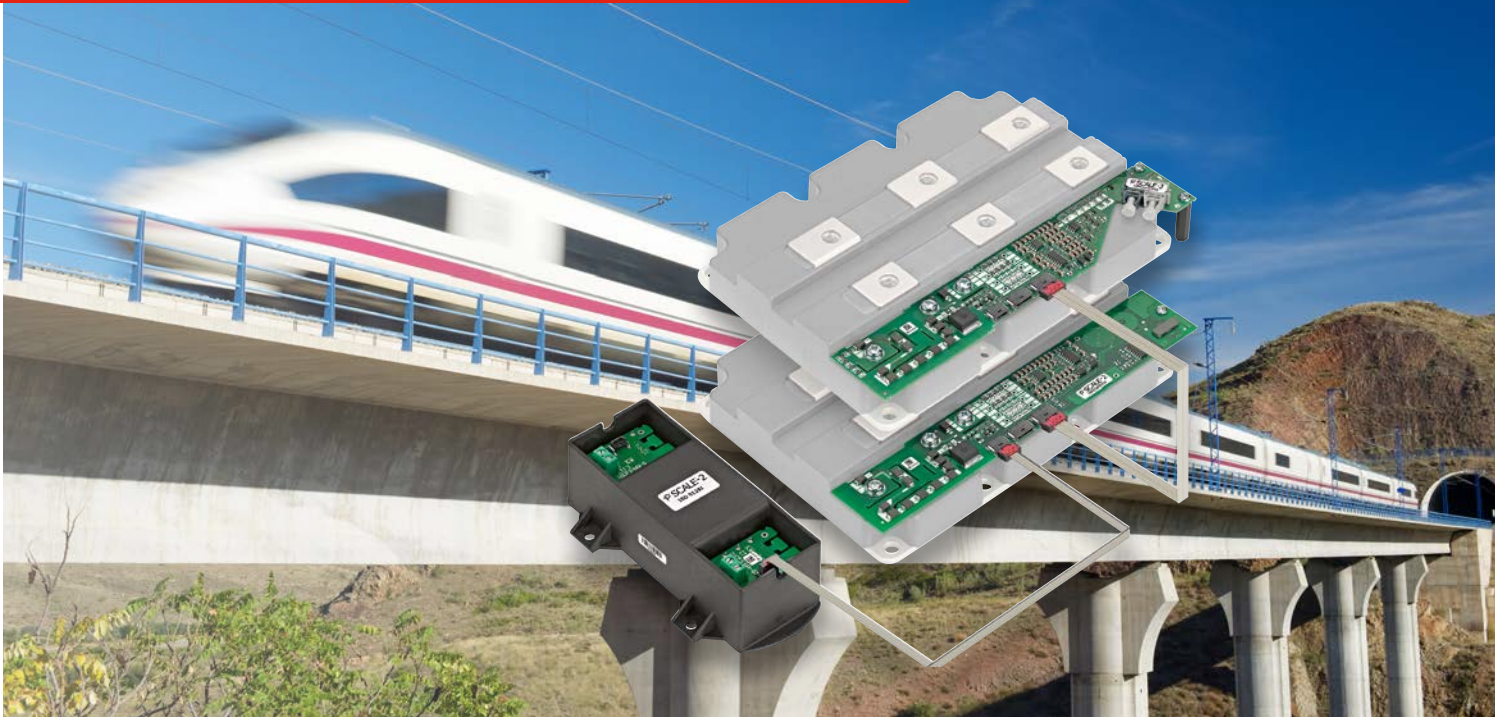

Compact plug-and-play gate driver for 4.5 kV IGBT modules in a low-voltage (6 kV IGBT module) package.

APPLICATIONS

- Traction inverters
- HVDC
- Wind power converters
- Medium and high-voltage drives
- Pulse power applications

CERTIFICATION

- Creepage and clearances according to IEC 60077-1
- UL compliant

POWER SUPPLY AND ELECTRICAL ISOLATION

The 1SP0340 driver is modular, so the driver card and power supply (DC-DC converter, ISO5125I see page 52) are two separate units. This means that any driver that has been developed to match a specific IGBT module can be used for any required isolation specification. Only the separate power supply (ISO51) must be selected to match the specific application. A further benefit is that drivers for 4.5 kV IGBTs can be implemented in two-level, three-level and multi-level inverter topologies. For parallel-connected drivers, only one power supply is needed per switch.

KEY FEATURES

- Single-channel IGBT gate driver
- Compact plug-and-play solution
- Fiberoptic interfaces
- +15 V (regulated)/-10 V gate driving
- Direct paralleling of IGBTs
- Two-level and multi-level topologies
- IGBT short-circuit protection
- Dynamic Advanced Active Clamping (DAAC)
- Supply undervoltage lockout
- Gate monitoring
- Active Miller clamping
- Easy mounting directly onto the IGBT
- External DC-DC converter ISO5125I necessary

KEY DATA OVERVIEW

Parameter	Min	Typical	Max	Unit
Nominal supply voltage		25		V
Supply current 1SP0340V2M0 @ $f_{IN}=0$ Hz		180		mA
Output power (1SP0340V2M0)		2.8		W
Gate voltage		± 15		V
Peak output current (gate current)	-35		+35	A
Switching frequency (f_s ¹⁾)	0		30	kHz
Duty cycle	0		100	%
Turn-on delay		170		ns
Turn-off delay		160		ns
Operating temperature	-40		+85	°C

¹⁾ Maximum switching frequency depends on the IGBT gate charge. See data sheet for actual value of specific driver.

APPLICATION CIRCUIT (1SP0340, ISO5125I)

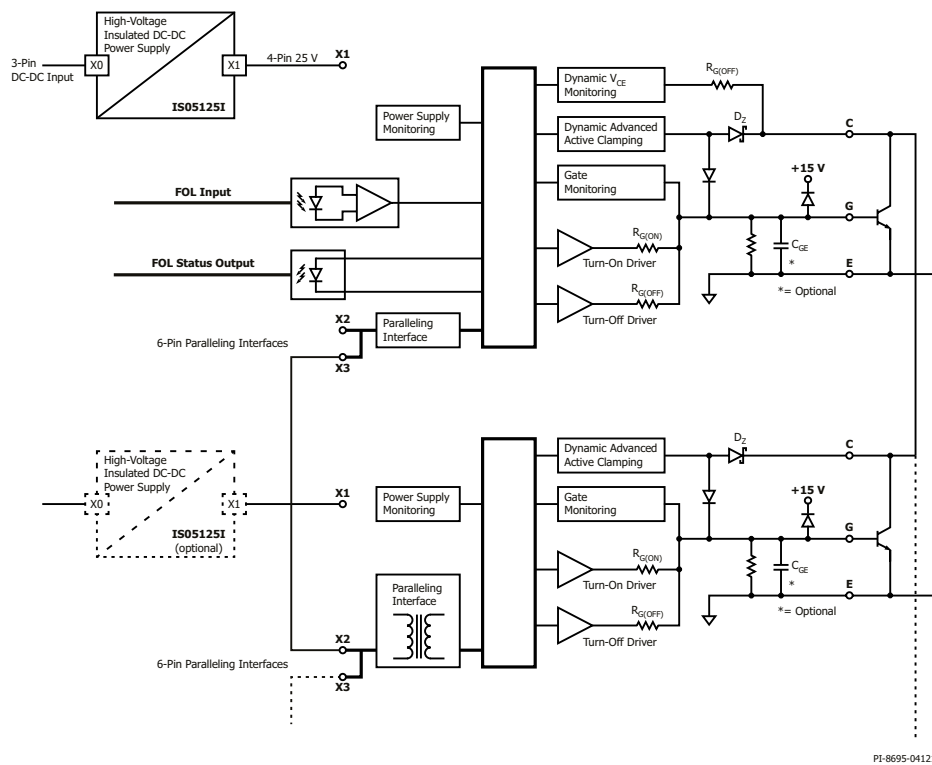

Fiberoptic links are used to electrically isolate the command and status feedback signals.

ORDERING INFORMATION

	V-Type (Master)	D-Type (Slave)
Type designation plus	1SP0340V2M0-xx	1SP0340D2S0-xx
xx: Voltage basic type	4500 V=45	
or xx: Specific module type	e.g., FZ1200R45HL3	
Module package	IHV 130/140; 190/140	
DC-DC converter	ISO5125I-xx (xx: 4500 V=45 / 6500 V=65 / 10000 V=100 / 12000 V=120)	
Input signal interface	Versatile FOL input/output	N/A
On-board connector	HFBR-2522ETZ/1522ETZ	N/A
Bus interface	X2/X3	
On-board connector	MBCON-6-1-0 (on 1SP0340)	
Connecting cable	MBC61-xxx-0 (xxx=030,050,070,110)	
Power supply	X0/X1	
User-board connector	Right angle MBCON-3-1-0; vertical MBCON-3-2-0	
Connecting cable driver/ISO	MBC41-xxx-0 (xxx=035,045,070,110)	
Connecting cable ISO/user board	MBC31-100-0	

SCALE-2 Plug-and-Play IGBT Gate Driver 1SP0335 and DC-DC Converter ISO5125I

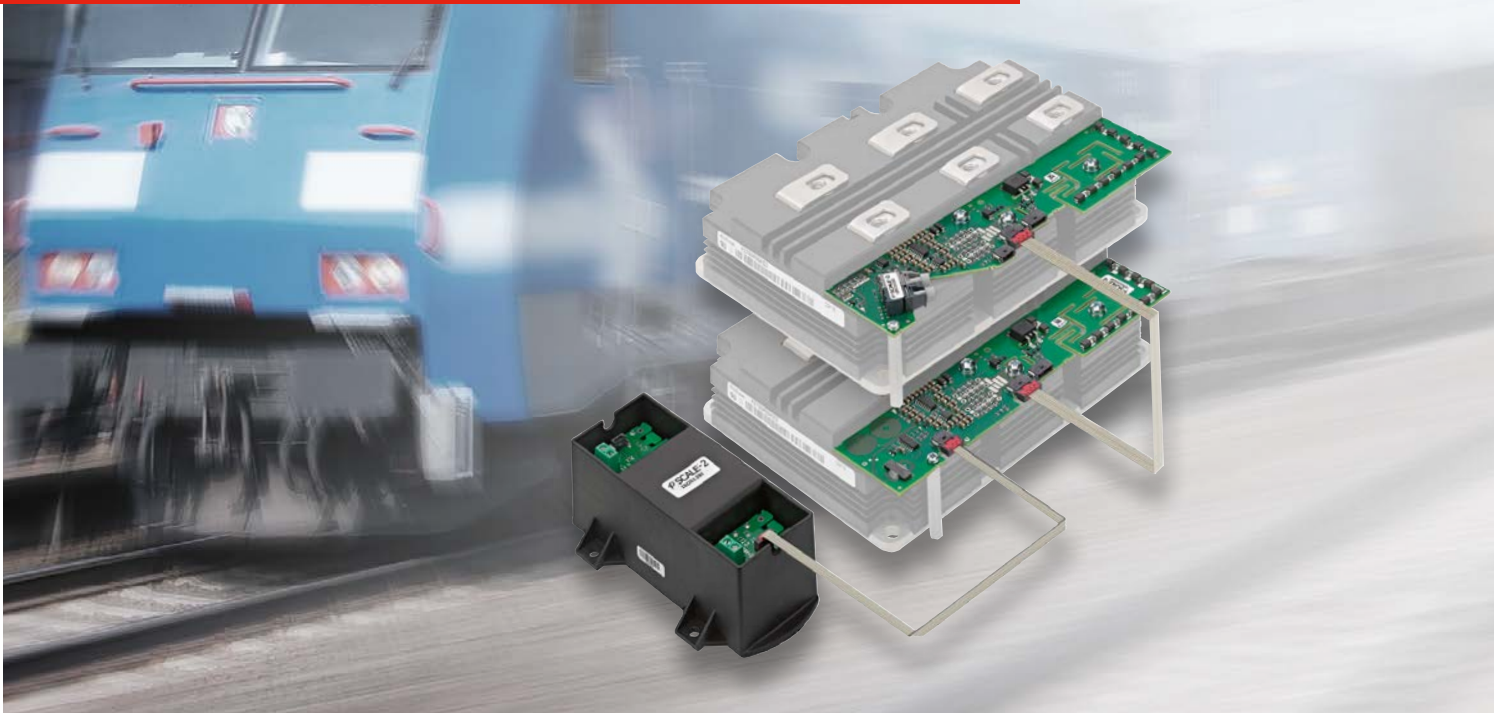

Single-channel driver 6.5 kV/4.5 kV with separate power supply unit for high-voltage (10.2 kV IGBT module) package.

APPLICATIONS

- Traction
- Railroad power supplies
- Light rail vehicles
- HVDC
- Flexible AC transmission systems
- Medium voltage converters
- Industrial drives
- Wind power converters

CERTIFICATION

- Creepage and clearances according to IEC 60077-1
- UL compliant

MASTER-SLAVE SYSTEM

The master (1SP0335V or 1SP0335S) can be used as a perfect standalone driver without a slave to drive IGBT modules without parallel connection or with up to three 1SP0335D slaves to drive up to four parallel-connected IGBT modules. Paralleling is achieved by simply connecting the master and slaves via paralleling interfaces. In contrast to other SCALE-2 plug-and-play drivers, the drivers of the 1SP0335 family are modular - driver card and power supply (DC-DC converter, ISO5125I see page 52) are two separate units. Therefore, any driver unit that matches a specific IGBT module can be used for any insulation specifications. A separate PSU ISO5125I must be chosen for a specific application.

KEY FEATURES

- Single-channel driver
- Compact plug-and-play solution
- Fiberoptic interfaces
- +15 V (regulated)/-10 V gate driving
- Direct paralleling of IGBTs
- Two-level and multi-level topologies
- Dynamic IGBT short-circuit protection
- Dynamic Advanced Active Clamping (DAAC)
- Supply undervoltage lockout
- Easy mounting directly onto the IGBT
- Extremely reliable, long service life
- External DC-DC converter ISO5125I necessary

KEY DATA OVERVIEW

Parameter	Min	Typical	Max	Unit
Nominal supply voltage		25		V
Supply current 1SP0335x2Mx @ $f_{IN}=0$ Hz		45		mA
Per additional 1SP0335D2Sx @ $f_{IN}=0$ Hz		20		mA
Output power (1SP0335V2Mx)		3.5		W
Output power (1SP0335D2Sx)		3.3		W
Gate voltage		+15/-10		V
Peak output current (gate current)	-35		+35	A
Switching frequency (f_s ¹)	0		30	kHz
Duty cycle	0		100	%
Turn-on delay		190		ns
Turn-off delay		185		ns
Operating temperature	-40		+85	°C

¹) Maximum switching frequency depends on the IGBT gate charge. See data sheet for the value of a specific driver.

APPLICATION CIRCUIT (1SP0335 AND DC-DC ISO5125I)

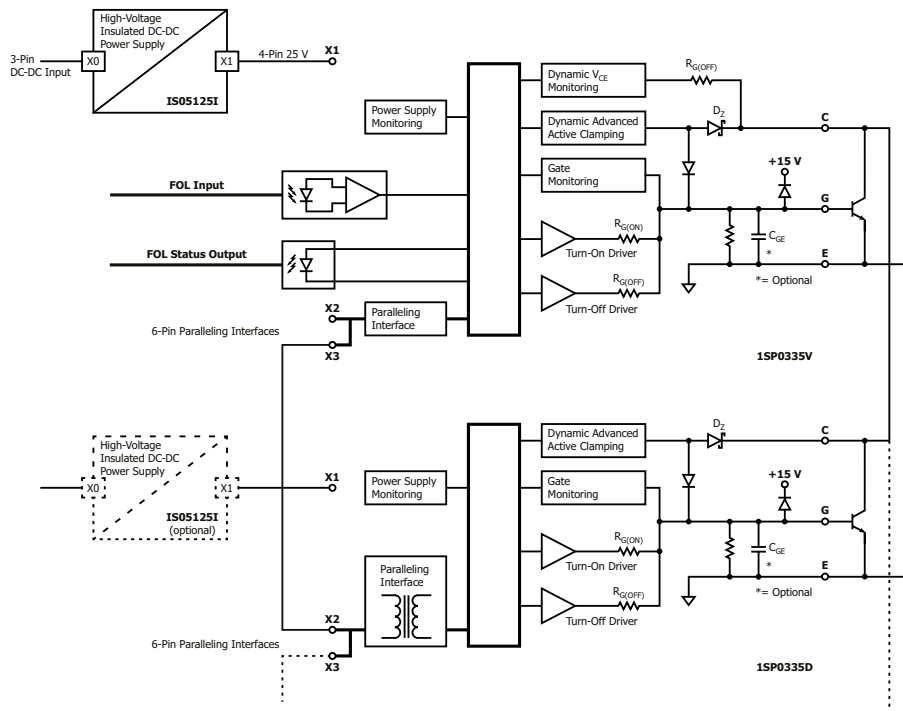

ORDERING INFORMATION

	V-Type (Master)	S-Type (Master)	D-Type (Slave)
Type designation plus	1SP0335V2M1-xx	1SP0335S2M1-xx	1SP0335D2S1-xx
xx: Voltage basic type or xx: Specific module type	3300 V=33 / 4500 V=45 / 6500 V=65 e.g., 5SNA1200G330100		
Module package	IHV 130/140; 190/140		
DC-DC converter	ISO5125I-xx (xx: 4500 V=45 / 6500 V=65 / 10000 V=100 / 12000 V=120)		
Input signal interface	Versatile FOL input/output	ST FOL input/output	N/A
On-board connector	HFBR-2522ETZ/1522ETZ	HFBR-2412Z/1412Z	N/A
Bus interface	X2/X3		
On-board connector	MBCON-6-1-0 (on 1SP0335)		
Connecting cable	MBC61-xxx-0 (xxx=030,050,070,110)		
Power supply	X0/X1		
User-board connector	Right angle MBCON-3-1-0; vertical MBCON-3-2-0		
Connecting cable driver/ISO	MBC41-xxx-0 (xxx=035,045,070,110)		
Connecting cable ISO/user board	MBC31-100-0		

DC-DC Converter for SCALE-2 Plug-and-Play Gate Drivers ISO5125I



For 3.3 kV to 6.5 kV SCALE-2 plug-and-play gate drivers.

APPLICATIONS

- Traction
- Railroad power supplies
- Light rail vehicles
- HVDC
- Flexible AC transmission systems
- Medium voltage converters
- Industrial drives
- Wind power converters

KEY FEATURES

- Operating voltage up to 12 kV peak
- Dielectric test voltage up to 18 kVAC
- Creepage distance 60 mm
- Output power 5 W
- Reliable, long service life
- Outstanding coupling capacitance 4 pF

ELECTRICAL INSULATION AND POWER SUPPLY WITH ISO5125I

The ISO5125I is a single-channel isolated DC-DC converter suitable as a power supply for IGBT drivers up to 6.5 kV. It complements Power Integrations' 1SP0335 and 1SP0340 high voltage plug-and-play gate drivers. Its output power of 5 W enables switching frequencies up to 5 kHz for 6.5 kV/750 A IGBTs. It enables IGBTs drivers in the 3.3 kV to 6.5 kV voltage range to be implemented in two-level, three-level and multi-level inverter topologies.

The driver unit is mounted directly onto the IGBT module by means of three screws. The power supply unit ISO5125I is designed as a separate module, to be attached close to the IGBT. For parallel-connected drivers, only one power supply is needed per switch.

Application Notes



For better understanding and easier design with SCALE gate drivers, Power Integrations offers detailed application notes with test data, PCB layout references, topology application suggestions and other useful information.

- Typical application failures
- EMI requirements
- Clearance and creepage distances for PCB
- External implementation guidance

KEY APPLICATION NOTES

AN-1001: IGBT AND MOSFET DRIVERS CORRECTLY CALCULATED

This application note describes the calculation of gate driver performance figures required for a given application. The values derived from this application note serve as a basis for selecting the most appropriate driver.

AN-1101: APPLICATION WITH SCALE-2 AND SCALE-2+ GATE DRIVER CORES

This application note highlights important design rules and helps to speed up development time by showing detailed examples about how to successfully design IGBT drivers for industrial and traction applications. Considered SCALE driver cores are: 2SC0108T, 2SC0435T, 2SC0650P and 1SC2060P.

AN-1301: DO'S AND DON'TS WITH SCALE-2 GATE DRIVERS

This application note highlights important points that must be considered when using SCALE-2 driver cores, as well as plug-and-play drivers (complements Application Note AN-1101).

AN-1601: CONTROLLING SiC MOSFET POWER SWITCHES WITH SCALE-2 AND SCALE-2+ GATE DRIVERS CORES AND SCALE-iDRIVER GATE DRIVER ICs

This application note discusses procedures to use SCALE gate drivers with SiC MOSFET switches.

More Application Notes available for download here:
gate-driver.power.com/design-support/application-notes/



Conformal Coating for Gate Drivers



In-line conformal coating enhances reliability and protection.

APPLICATIONS

- Offshore and onshore wind parks
- Traction main and auxiliary inverter
- HVDC stations
- Photovoltaic installations
- Medium voltage drives in mining and oil and gas industry

QUALIFICATION

- Qualification is based on tests in accordance with IEC 60068-2-xx
- Vibration (sinusoidal) test parameters according to IEC 60068-2-6:2008-10
- Shock test parameters according to IEC 60068-2-27:2010-02
- Damp heat, steady-state test parameters according to IEC 60068-2-78:2012-10
- Cold test parameters according to IEC 60068-2-1:2007-03
- Dry heat test parameters according to IEC 60068-2-2:2007-07
- Thermal cycle test parameters according to IEC 60068-2-14:2009-01
- Salt mist test test parameters according to IEC 60068-2-11

KEY FEATURES

- Reduced total cost of ownership and streamlined production
- Internal solutions and specialized subcontractors become obsolete
- Full conformal coating qualification with testing in accordance with IEC 60068-2 standards
- Controlled process with 100% optical inspection at end of line
- SCALE-2+ gate driver cores with UL recognition:
 - E321757 for UL508C (NMMS2/8)
 - E346491 for UL60950-1C (NWGQ2/8)

CONFORMAL COATING: IN-LINE PROCESS FLOW



TYPICAL COATED AND KEEP OUT AREAS (2SP0320V2AX-XXXX)

Top side

Bottom side

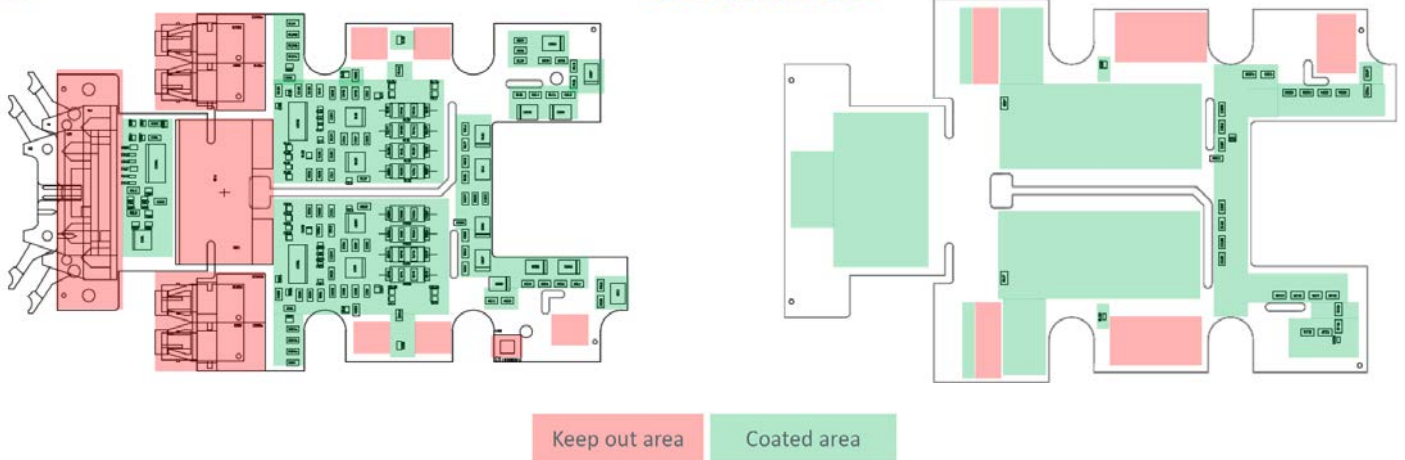

ORDERING INFORMATION

Part Number	Page	Part Number	Page
2SC0106T2A1C-12 (1)	20-21	2SC0435T2H0C-17 (1)	26-27
2SC0108T2G0C-17 (1)	24-25	2SP0115T2A0C-xxxx (2)	42-43
2SC0108T2F1C-17 (1)	24-25	2SP0115T2B0C-xxxx (2)	42-43
2SC0108T2G0C-17 (1)	24-25	2SP0115T2C0C-xxxx (2)	42-43
2SC0108T2H0C-17 (1)	24-25	1SP0335V2M1C-xxxx (2)	52-53
2SC0108T2D0C-12 (1)	24-25	1SP0335S2M1C-xxxx (2)	52-53
2SC0435T2F1C-17 (1)	26-27	1SP0335D2S1C-xxxx (2)	52-53

For additional products, please contact: gate-drivers.sales@power.com

SiC-MOSFET Gate Driver 600 V - 4500 V

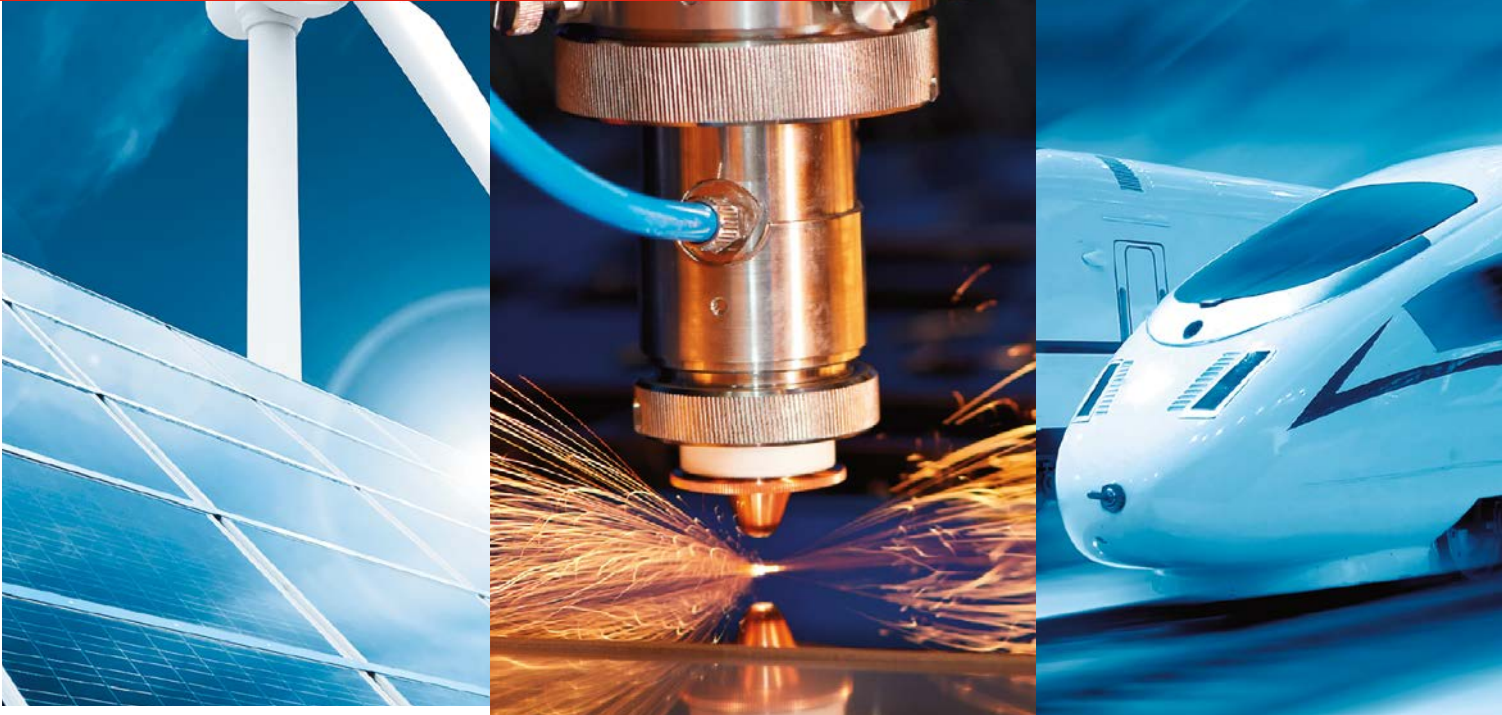

KEY FEATURES

- Variable gate voltage by VEE circuit 0 V to 25 V, 0 V to 10 V = 28 V
- $\leq 2 \mu\text{s}$ short-circuit response time
- High output current capability
- High isolation capability
- Advance active clamping with dv/dt feedback
- High switching frequency up to 500 kHz
- SiC-MOSFET breakdown voltage up to 4.5 kV
- High MTBF/low FITrate
- Broad portfolio
- Paralleling of MOSFET module
- Proven designs
- Suitable for all SiC-MOSFET designs
- Application defaults by request

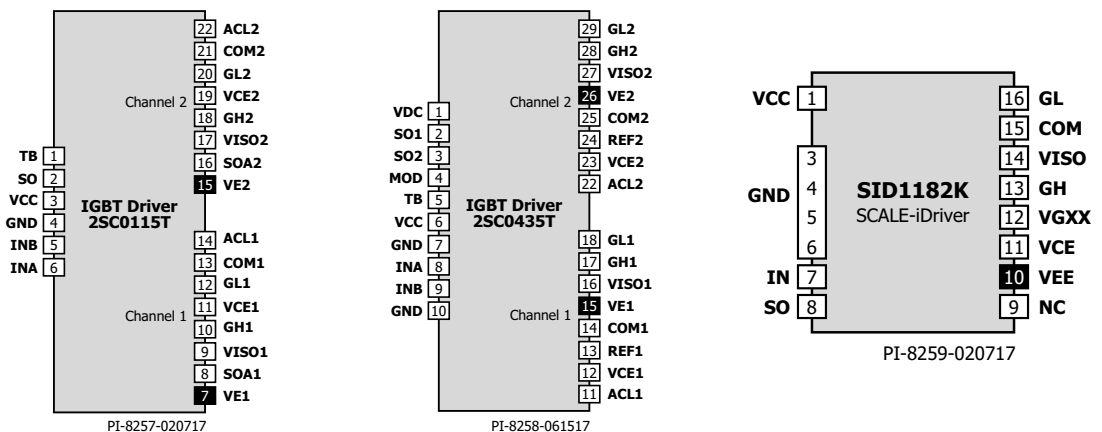

Figure 1.

Pinning of different SCALE gate drivers with marked VEx/VEE pins (gate driver cores 2SC0115T and 2SC0435T and driver IC SID1182K)

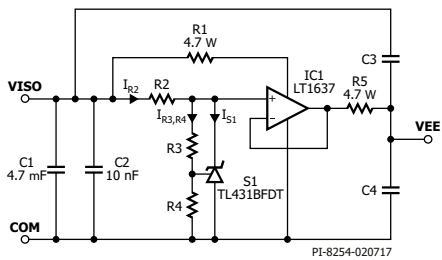

Figure 2.
VEE-Regulator for SiC MOSFET switches with regulated negative rail

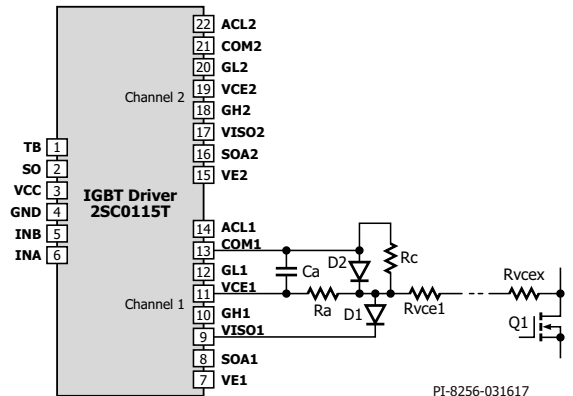

Figure 3.
Modified setting for SiC MOSFET short-circuit detection

GATE DRIVERS



SCALE-iDriver



2SC0115T-12



2SC0435T-17



2SC0535T-17



2SC0635T-45



2SC0650P-17



1SC2060P-17

APPLICATION NOTE

AN-1601: Controlling SiC MOSFET Power Switches with SCALE-2 and SCALE-2+ Gate Drivers Cores and SCALE-iDriver Gate Driver



Besides driving conventional Si-based power devices like IGBTs and MOSFETs, which require turn-on and turn-off gate voltages of 15 V / -10 V and 10 V through 20 V / 0 V respectively, SCALE-2 and SCALE-2+ gate driver cores plus SCALE-iDriver gate driver ICs are also able to drive SiC MOSFET power switches. However, SiC switches often require turn-on and turn-off voltage levels which are different from those required by Si-based devices.

