

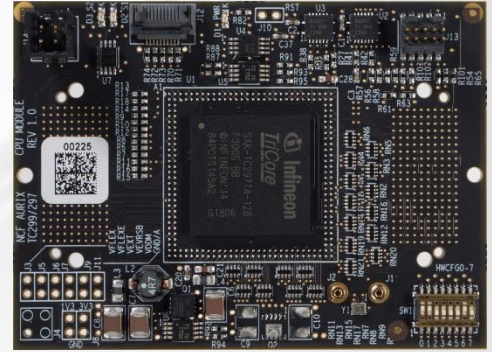

**Designed by Engineers for Engineers**

## AURIX™ TC299/297/277 MCU Platform Module

Designed for use with either REDline Carrier board, or as a standalone development platform



### Overview

- This Module can host a number of AURIX™ MCU derivatives.
- The Module also supports easy integration into the customer's target platform as MCU pins are routed out to two 200 position pad arrays on the bottom.
- All important standalone operations are made possible by incorporating essential power conversion, clock, system configuration, programming and debugging connections on the Module itself.
- Separated Analog and Digital domains make full use of MCU's 24-bit Analog-to-Digital Converters.
- The supplied software (Board Support Package) has all necessary parts for MCU boot configuration, start-up, and multicore operations, all written in C code.
- Complete hardware development support: schematics, BOM, layout, gerbers, PCB stack-up, and high-speed design rules.

### Features

- Infineon AURIX™ SAK-TC2gx MCU pin-compatible versions (299/297/277)
- Up to 3 cores @300MHz, 8MB flash, 2.7MB SRAM with HSM and ADAS
- Default 20MHz crystal with optional socket for custom crystal
- Core voltage SMPS for 1.3V generation (optional LDO) and 5V to 3.3V LDO for I/O supply
- Infineon DAP 10-position programming and debugging header (or alternative JTAG)
- Generic UART/CLI 4-pin header with USB cable
- High-speed AURORA trace buffer connector for Emulation Devices
- MCU and LDO temperature sensors connected to on-board I<sup>2</sup>C bus
- System and MCU configuration 8-position DIP switch
- "No solder" headers to configure Module in standalone mode and external power
- Critical voltage rails' supervisor with LED
- User status and Reset LED
- Very compact design for easy target integration, line-up compatible with remaining TC2xx series

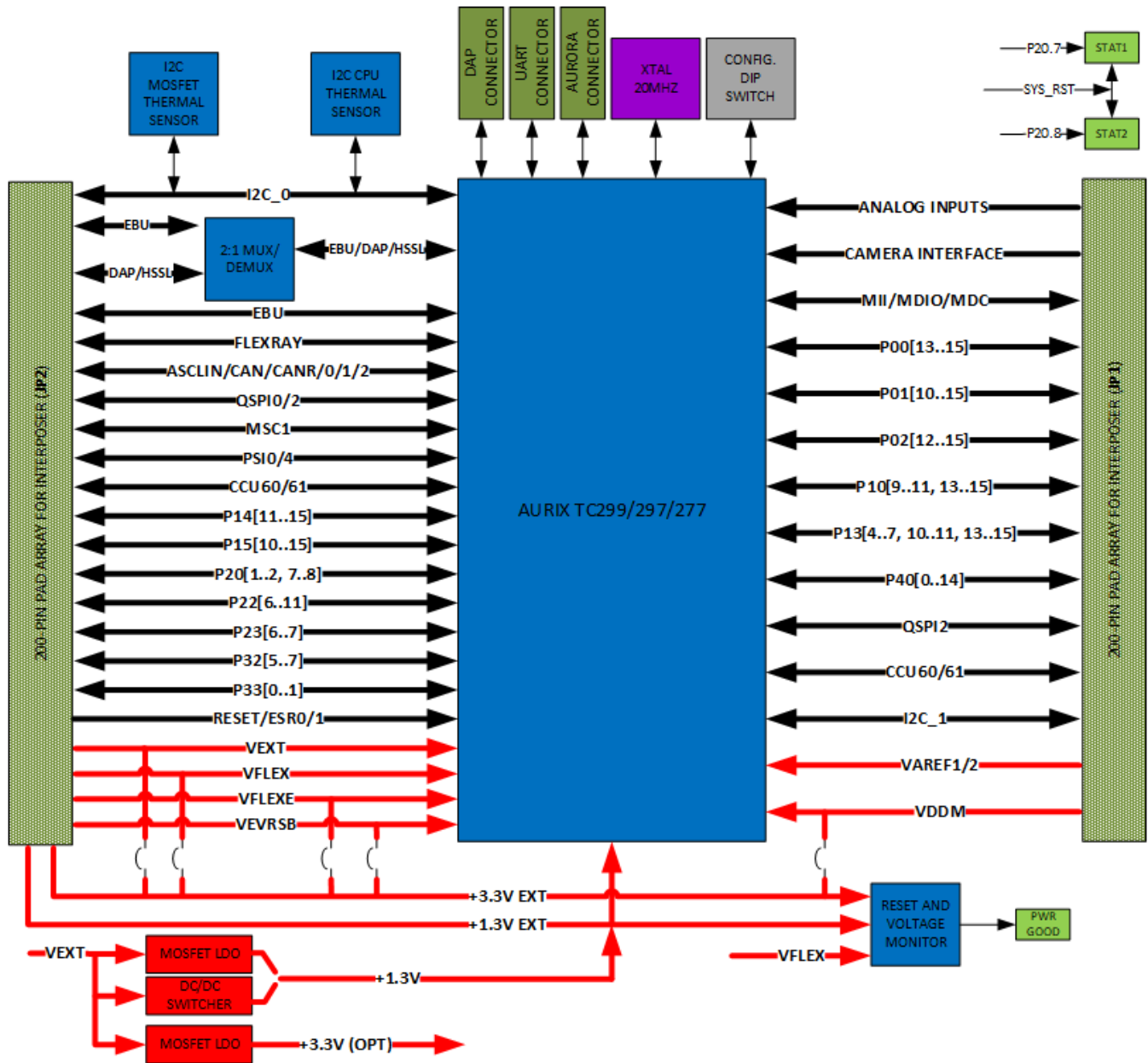

## Compatibility

- The Module is designed to work with AURIX™ Base Carrier Development Platform

## Ordering Information

- Module Part Number: RDL-CPU29w-SSxx-EVR13yy-zzz

