

Solid State Motor Contactor 3 Phase Motor Reversing Types REC2R



- AC electronic motor Reversing Relay
- Instantaneous Switching
- Three phase with two pole switching
- Control status LED indication
- Two control input ranges: 24 VAC/DC, 90-253 VAC
- Motor rating up to 3kW (3.0 HP)
- Rated Operational Voltage up to 600 VAC
- Opto-isolation at 4kVrms
- Mechanical Contactor resemblance with covered heatsink
- DIN-rail and panel mounting

Product Description

REC2R is a 3-phase electronic motor reversing relay. L1-T1 and L3-T3 poles are switched while L2, T2 pole is a direct connection from L2 phase to the motor. A front dual colour LED, lights green when the motor is running in the forward direction upon application of control voltage to A2-A3 terminals.

Motor runs in the reverse direction when control voltage is applied to terminals A1- A2 and the LED lights red. The integrated electronic interlock

prevents short circuit between phases in case a control signal is applied for forward and reverse directions simultaneously through the pluggable connector on the front. In such a case REC switches off until one of the control signals is removed.

REC can control motors up to 7.6 AAC and goes up to 600 VAC rating. An adaptor for underlying overload modules is available. Specifications are stated at 25°C unless specified.

Ordering Key **REC 2 R 48 A 2 0 G K E**

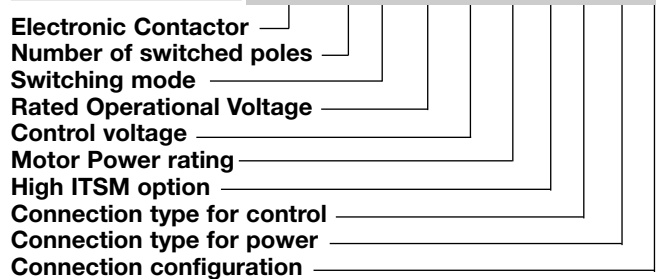

Ordering Key

Switching poles	Switching mode	Rated operational voltage	Control voltage	Motor power rating	Itsm control	Connection control	Connection power	Configuration
REC2: 2 poles	R: Reversing	48: 48-530 VAC 60: 48-600 VAC	D: 24 VDC, -15%, + 20% A: 90 - 253 VAC	2: 2.2kW 3: 3.0kW	0: Standard Itsm	G: Clamp R: Spring*	K: Screws	E: Contactor

* Available on request

Selection Guide

Rated Voltage	No of Poles	Control voltage	Power Rating @ 400 VAC	
			2.2kW	3.0kW
48-530 VAC	2	24VDC	REC2R48D20GKE	REC2R48D30GKE
		90-253VAC	REC2R48A20GKE	REC2R48A30GKE
48-600 VAC	2	24VDC	-	REC2R60D30GKE
		90-253VAC	-	REC2R60A30GKE

* According to EN61131-2

General Specifications

	REC..48..	REC..60..
Rated Operational voltage	480 VAC	600 VAC
Operational voltage Range	48-530 VAC	48-600 VAC
Blocking voltage	1200 Vp	1600 Vp
Operational frequency range	45 - 65 Hz	45 - 65 Hz
Power factor	>0.5 @ rated voltage	>0.5 @ rated voltage

Control specifications

	REC...D..	REC...A..
Rated control input voltage	24 VDC	230 VAC
Control voltage range	15-32 VDC (according to EN61131-2)	90 - 253 VAC
Maximum Input current	10 mA	15 mA
Pick-up voltage	15 VDC	90 VAC
Maximum Reverse voltage	32 VDC	N/A
Drop-out voltage	1 VDC	10 VAC
Response time pick-up	5 ms	30 ms
Response time drop-out	15 ms	30 ms
Operational frequency range	N/A	45 - 65 Hz
Maximum Time delay F- -> R, F <-- R	80 ms	100 ms
LEDs	Forward: Green Reverse: Red	Forward: Green Reverse: Red

Connection Specifications

POWER CONNECTIONS (75°C, Copper Cables)

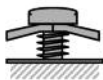
Connection Type	Screw terminal
Illustration of terminal	
Rigid (Solid)	2 x 1.5..2.5mm ² (2 x AWG16..14) 2 x 2.5..6mm ² (2 x AWG14..10)
Finely stranded with end sleeve	2 x 1..2.5mm ² (2 x AWG17..14) 2 x 2.5..6mm ² (2 x AWG14..10) 1 x 10mm ² (1 x AWG8)
Flexible w/o end sleeves	2 x 1.5..2.5mm ² (2 x AWG16..14) 2 x 2.5..6mm ² (2 x AWG14..10)
Stripping length	10mm
Tightening torque	2Nm (Pozidriv 2 bit)
Screw size	M4
Aperture for termination lug (fork type)	Max 11mm

CONTROL CONNECTIONS (75°C, Copper Cables)

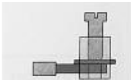
Connection Type	Spring loaded*	Captive Clamp
Illustration of terminal		
Type	Pluggable	Pluggable
Stranded	-	1 x 0.05..1.5mm ² (1 x AWG30..16)
Solid	1 x 0.05..2.5mm ² (1 x AWG 24..14)	1 x 0.05..2.5mm ² (1 x AWG30..14)
Stripping length	10mm	6 - 7.5mm
Tightening torque	N/A	0.5Nm (Philips bit)
Screw Size	N/A	M3
Withdrawal Force	1.5N	1.5N
Insertion Force	3N	3N
Max Contact Resistance	15mΩ	15mΩ

* Available on request

Load Specifications

	@ 40°	@ 50°	@ 60°	@ 40°	@ 50°	@ 60°	I _{min}	I _{tsm}
Rated Operational Current AC-53a @ 400Vrms, to IEC, for trip Classes 10, 20, 30 Horizontal space between units	45 mm			0 mm			All Cases	
REC.....20	6.2A	5.8A	5.3A	5.8A	5.3A	4.3A	400mA	600A _p
REC..48..30	7.6A	6.8A	6.2A	5.8A	5.8A	4.9A	400mA	600A _p
REC..60..30	7.6A	6.8A	6.2A	-	-	-	400mA	600A _p
No. of poles	2							
Maximum On-state voltage drop @ rated current	1.6 Vrms							
Off-state leakage current @rated voltage and frequency	< 3 mArms							
Critical dV/dt*	1000V/us							

Motor Rating (45mm space between adjacent units)

	HP @ 40 / 50 / 60°C, according to UL508				kW @ 40 / 50 / 60°C, according to IEC60947-4-2			
	230V	400V	480V	600V	230V	400V	480V	600V
REC2...20	1½ / 1 / 1	3 / 2 / 2	3 / 3 / 3	-	1.5 / 1.1 / 1.1	2.2 / 2.2 / 2.2	3.0 / 3.0 / 2.2	-
REC2..48..30	2 / 2 / 1	3 / 3 / 3	5 / 3 / 3	-	1.5 / 1.5 / 1.5	3.0 / 2.2 / 2.2	4.0 / 3.0 / 3.0	-
REC2..60..30	2 / 2 / 1½	3 / 3 / 3	5 / 3 / 3	5 / 5 / 5	1.5 / 1.5 / 1.5	3.0 / 2.2 / 2.2	4.0 / 3.0 / 3.0	5.5 / 4.0 / 4.0

Environmental Specifications

Operating Temperature	-25°C to 60°C
Storage Temperature	-40°C to 100°C
RoHS compliant	Yes
Impact resistance	15/11 g/ms
Vibration resistance	2g
Relative humidity	< 95% non-condensing @ 40 °C
Pollution degree	2
Installation category	III
Degree of finger protection	IP20
Installation altitude	0- 1000m. Above 1000m derate linearly by 1% of FLC per 100m up to a maximum of 2000m

* Specification @ T_j (init.) = 25°C and t = 10ms

Housing Specifications

Weight	approx 300g
Housing Material	Nylon PA66
Flame class	UL94-V0
Housing Colour	RAL7035
Dimensions (h x w x d) (without input plug)	105 x 45 x 90 mm

Isolation

Dielectric withstand voltage input to output	≥ 4000V AC rms
---	----------------

Short Circuit Protection (according to EN/IEC 60947-4-2 and UL508)

	REC2B48.20 REC3B.....20	REC2B...30 REC3B48...30	REC2B48..40
Short Circuit Current Rating	5kA	5kA	5kA
Type of coordination: 1			
UL rated short circuit current RK5 fuse	12A	15A	15A
Type of coordination: 2			
Rated short circuit Semiconductor fuse	Y220913 6.9 CP GRC 22.58 50	Y220913 6.9 CP GRC 22.58 50	Y220913 6.9 CP GRC 22.58 50

Agency Approvals & EMC

CE marking		UL Approval	cULus listed (E172877)
Low Voltage Directive	IEC / EN 60947-4-2	Restrictions of hazardous substances	RoHS
EMC Immunity	IEC / EN 61000-6-2	Radiated Radio Frequency Immunity	EN 61000-4-3 Performance criteria 1
EMC Emission	IEC / EN 61000-6-4	Electrical Surge Immunity	IEC / EN 61000-4-5 Output, line to line 1kV, performance criteria 1 Output, line to earth 2kV, performance criteria 1 Input, line to line 1kV, performance criteria 2 Input, line to earth 2kV, performance criteria 2
Electrostatic Discharge (ESD) Immunity	IEC / EN 61000-4-2 8kV, PC2 Air discharge 4kV, PC1 Contact	Conducted Radio Frequency Immunity	IEC / EN 61000-4-6 Performance criteria 1
Electrical Fast Transient Burst Immunity	IEC / EN 61000-4-4 Performance criteria 2 Performance criteria 1 Performance criteria 1	Voltage Dips Immunity	IEC / EN 61000-4-11 Performance criteria 2 Performance criteria 1
Output: 4kV / 5kHz		Radio Interference field emissions (radiated)	IEC / EN 55011, IEC/EN 60947-4-2 Class B (light industry)
Output: 2kV / 5kHz			
Input: 2kV / 5kHz			
Voltage Interruptions Immunity	IEC / EN 61000-4-11 Performance criteria 2		
0% for 5000ms			
Radio Interference voltage emissions (conducted)*	IEC / EN 55011, IEC/EN 60947-4-2 Class A (industrial)*		
150K - 30MHz			

* This product is designed and constructed as an EMC Class A device. The use of this product in residential applications could lead to radio interferences. In such applications, additional external filtering may be required.

Connection Diagrams

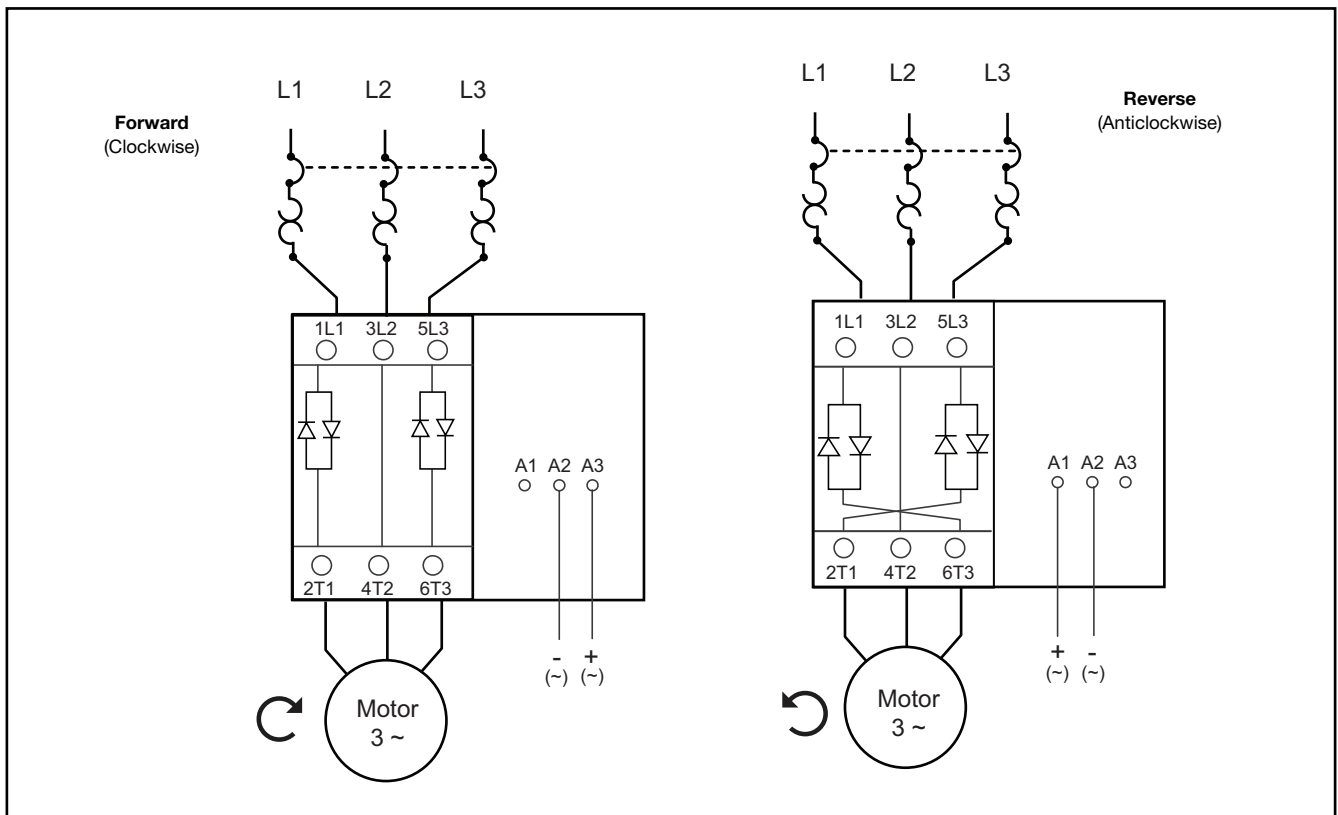

Dimensions

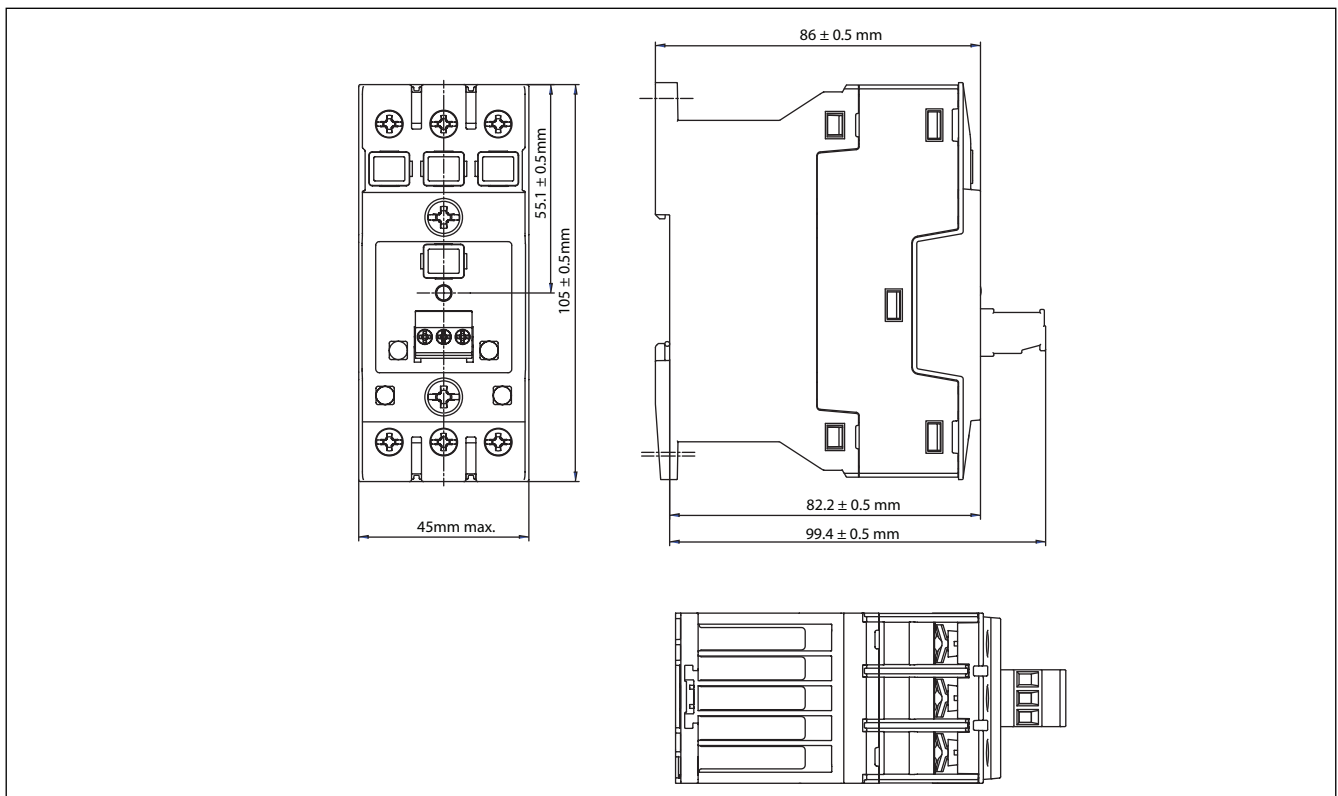

All dimensions in mm



Characteristic Curves and Operating Cycles

Maximum allowable number of starts depending on the T_n and T_{on}

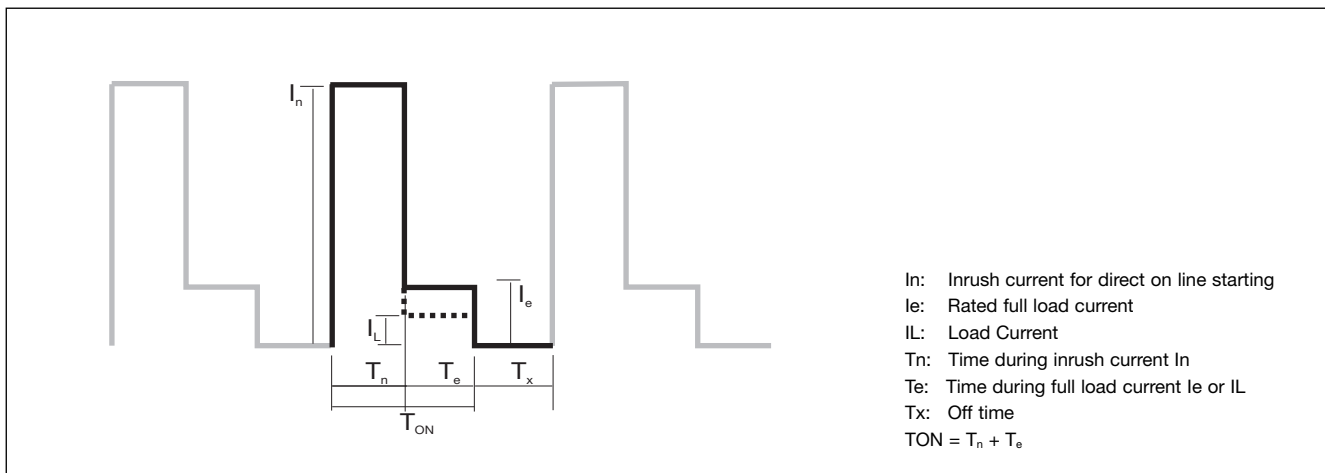

Curves: No. of switching cycles per hour versus t_{ON}

Chart No. 1

$$\frac{I_n}{I_e} = 7.2, \frac{I_L}{I_e} = 1$$

t_{ON} (s)	Number of Switches per Hour						
	$T_n = 0.05s$	$T_n = 0.1s$	$T_n = 0.2s$	$T_n = 0.4s$	$T_n = 0.8s$	$T_n = 1.6s$	$T_n = 3.2s$
0.1	1800	910	-	-	-	-	-
1	1500	800	420	220	102	-	-
10	380	300	250	160	90	40	15
100	38	38	38	35	35	25	6
1000	-	-	-	-	-	-	-

Chart No. 2

$$\frac{I_n}{I_e} = 7.2, \frac{I_L}{I_e} = 0.6$$

t_{ON} (s)	Number of Switches per Hour						
	$T_n = 0.05s$	$T_n = 0.1s$	$T_n = 0.2s$	$T_n = 0.4s$	$T_n = 0.8s$	$T_n = 1.6s$	$T_n = 3.2s$
0.1	1900	900	-	-	-	-	-
1	1800	850	440	120	110	-	-
10	390	390	350	190	100	50	25
100	38	38	38	38	25	25	20
1000	-	-	-	-	-	-	-

Chart No. 3

$$\frac{I_n}{I_e} = 4, \frac{I_L}{I_e} = 1$$

t_{ON} (s)	Number of Switches per Hour						
	$T_n = 0.05s$	$T_n = 0.1s$	$T_n = 0.2s$	$T_n = 0.4s$	$T_n = 0.8s$	$T_n = 1.6s$	$T_n = 3.2s$
0.1	5100	2800	-	-	-	-	-
1	2700	1900	1100	650	350	-	-
10	250	250	250	290	200	140	75
100	36	36	36	36	36	36	30
1000	-	-	-	-	-	-	-

Chart No. 4

$$\frac{I_n}{I_e} = 4, \frac{I_L}{I_e} = 0.6$$

t_{ON} (s)	Number of Switches per Hour						
	$T_n = 0.05s$	$T_n = 0.1s$	$T_n = 0.2s$	$T_n = 0.4s$	$T_n = 0.8s$	$T_n = 1.6s$	$T_n = 3.2s$
0.1	5500	2900	-	-	-	-	-
1	3400	2300	1400	700	350	-	-
10	350	350	350	350	280	170	80
100	36	36	36	36	36	36	36
1000	-	-	-	-	-	-	-