

- NOTES:
 1. INSTALL MT FERRULE WITH EPOXY WINDOW FACING AWAY FROM PCB.
 2. INSTALL THE FERRULE FIRST, THEN MATE FIREFLY.
 3. ALL ASSEMBLIES TO BE 100% TESTED.
 4. SEE PICS FOR PACKAGING INSTRUCTIONS.

DO NOT SCALE FROM THIS PRINT

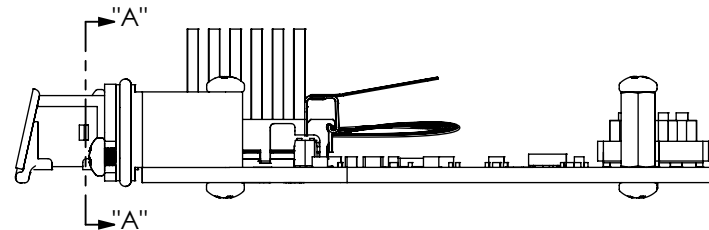
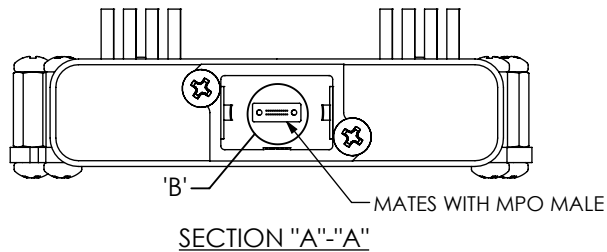
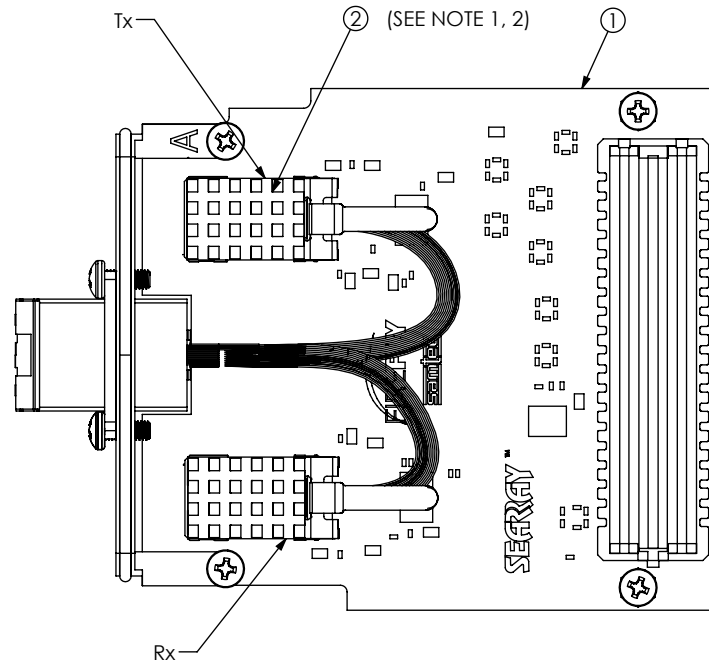
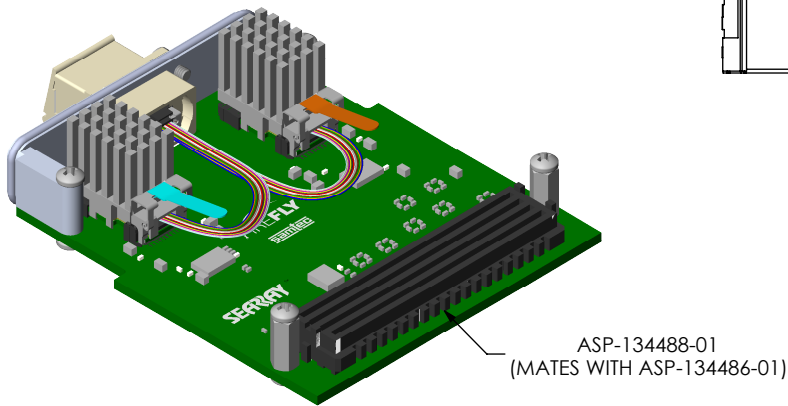
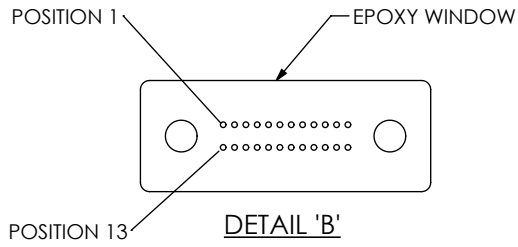

OPTICAL SIGNAL MAP	
FUNCTION	MTP POSITION
Rx0	1
Rx1	2
Rx2	3
Rx3	4
Rx4	5
Rx5	6
Rx6	7
Rx7	8
Rx8	9
Rx9	10
NC	11
NC	12
Tx0	13
Tx1	14
Tx2	15
Tx3	16
Tx4	17
Tx5	18
Tx6	19
Tx7	20
Tx8	21
Tx9	22
NC	23
NC	24

BOM TABLE					
ITEM	PART NUMBER	DESCRIPTION	QTY	COST QTY	UOM
1	PCBA-193428-01	PCBA ASSEMBLY	1	1	EACH
2	OTP-192287-01-ECUO	FIREFLY ASSEMBLY	1	1	EACH
3	MTP-24-LOOPBACK-OM3-M*	OPTICAL LOOPBACK	1	1	EACH
4	FP-FMC002*	PACKAGING BOX	1	1	EACH
5	S-FMC002*	PACKAGING SLEEVE	1	1	EACH
6	BG-04-06*	ESD BAG	2	2	EACH
7	LABEL-SENSITIVE-ELE*	ESD STICKER	1/500	1/500	EACH
8	CCS-197627-01-MC*	INSERT	1	1	EACH
9	LABEL-MAIL-1IN-CLR*	LABEL	2	2	EACH
10	CCS-197624-01-MC*	CLEANING STICK	1	1	EACH
11	CCS-197623-01-MC*	CLEANING PAD	1	1	EACH

*ITEM NOT SHOWN

UNLESS OTHERWISE SPECIFIED, DIMENSIONS ARE IN INCHES.
 TOLERANCES ARE:
 DECIMALS ANGLES
 .XX: ±.01[.3] 2°
 .XXX: ±.005[.13]
 .XXXX: ±.0020[.051]

PROPRIETARY NOTE
 THIS DOCUMENT CONTAINS CONFIDENTIAL AND PROPRIETARY INFORMATION AND ALL DESIGN, MANUFACTURING, REPRODUCTION, USE, PATENT RIGHTS AND SALES RIGHTS ARE EXPRESSLY RESERVED BY SAMTEC, INC. THIS DOCUMENT SHALL NOT BE DISCLOSED, IN WHOLE OR PART, TO ANY UNAUTHORIZED PERSON OR ENTITY NOR REPRODUCED, TRANSFERRED OR INCORPORATED IN ANY OTHER PROJECT IN ANY MANNER WITHOUT THE EXPRESS WRITTEN CONSENT OF SAMTEC, INC.

DO NOT SCALE DRAWING SHEET SCALE: 1:2



520 PARK EAST BLVD, NEW ALBANY, IN 47150
 PHONE: 812-944-6733 FAX: 812-948-5047
 e-Mail info@SAMTEC.com code 55322

DESCRIPTION:	14 GBPS FIREFLY FMC DEVELOPMENT KIT
DWG. NO.	REF-193429-01
BY: BRYANG	6/2/2016 SHEET 1 OF 1