

# Zenon 2.4GHz Antenna

Part No. SR4W030 REFLECTOR<sup>®</sup> Product Specification

## 1. Features

- REFLECTOR<sup>®</sup> Technology
- Antenna for 2.4GHz applications
- Bluetooth, Wi-Fi, ZigBee, ISM.
- Maintains high performance within device: DFI (Designed For Integration)
- 1.13mm diameter RF cable with IPEX MHF connector
- Self-Adhesive mounted
- Quick integration minimizes design cycle
- High performance
- Available in 2 standard cable lengths

## 2. Description

Zenon is intended for use with all Wi-Fi/BT/ISM applications. A rigid antenna with cable enables direct connection to the host device (Plastic/Metal/PCB). The antenna can be placed against any material and will not detune. Simple integration with plug and play simplicity. This product specification shows the performance of the antenna to cover the frequency range: 2.4-2.5 GHz.

## 3. Applications

- Smart lighting
- Portable Devices
- Set-Top-Box
- Network Devices
- Wearable devices
- MIMO Systems



Patent pending

## 4. Part Number

Zenon: SR4W030-xxx



Note. -xxx refers to cable length option:

Part Number	Cable Length
SR4W030-100	100mm
SR4W030-150	150mm



## 5. General Data

Product name	Zenon
Part Number	SR4W030
Frequency	2.4-2.5 GHz
Polarization	Linear
Operating temperature	-40°C to +85°C
Impedance with matching	50 Ω
Weight	< 0.5 g
Antenna Assembly type	FR4 Self-adhesive (3M 468MP)
Dimensions (Antenna)	23.0 x 16.0 x 1.6 (mm)
Cable length	100 / 150 (mm)
Connection	MHF IPEX

## 6. RF Characteristics

The RF characteristics are shown with the antenna placed in three scenarios:

- 1) **Placed on Metal surface (RF GND Plane)**
- 2) **Free space**
- 3) **Placed on metal surface (Floating unconnected copper)**

	2.4 – 2.5 GHz		
	Metal (RF GND)	Free space	Metal (Floating)
			
Peak gain	5.20dBi	2.60dBi	3.30dBi
Average gain	-3.00dBi	-2.50dBi	-3.00dBi
Average efficiency	>50%	>60%	>50%
Maximum return loss	<-8.0dB	<-9.3dB	<-8.0dB
Maximum VSWR	2.30:1	2.00:1	2.30:1

## 7. RF Performance

### 7.1 Return Loss

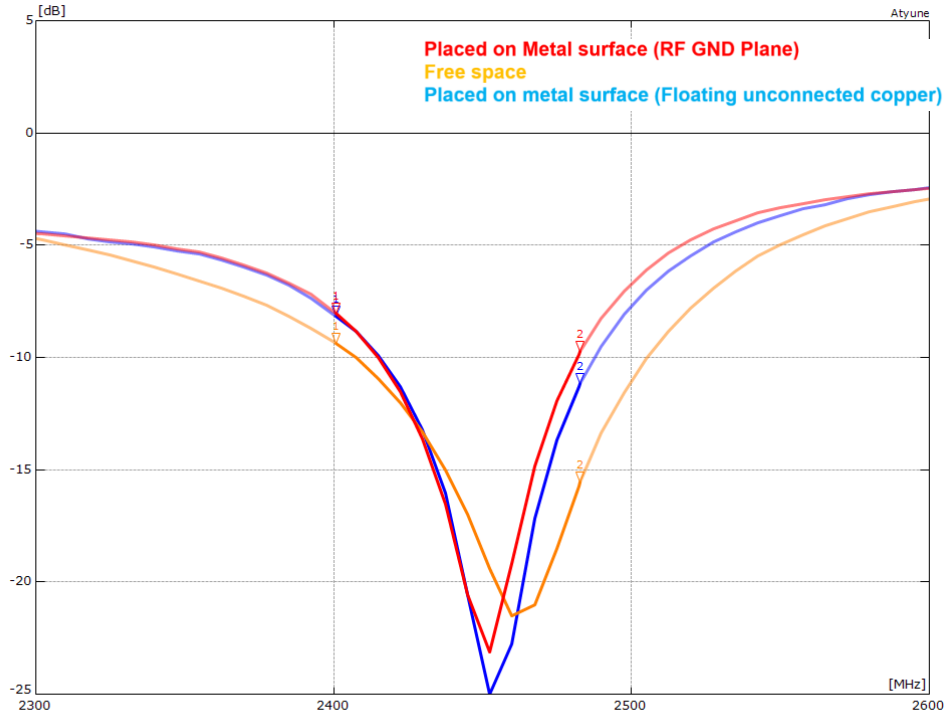

### 7.2 VSWR

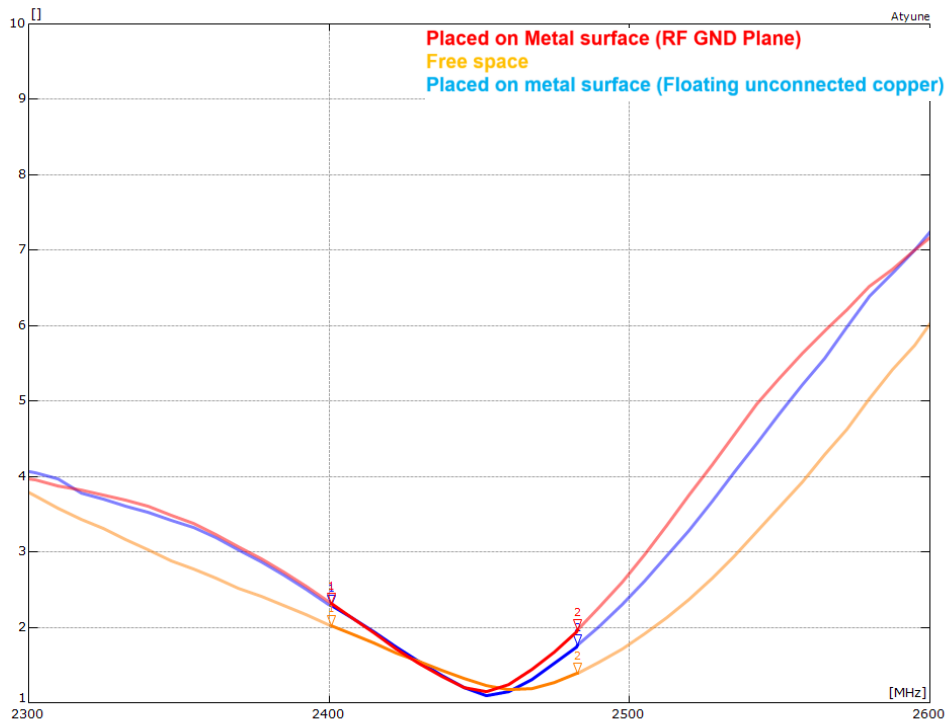

## 7.3 Antenna Pattern Free Space

### 7.3.1 2400 MHz – 2500 MHz

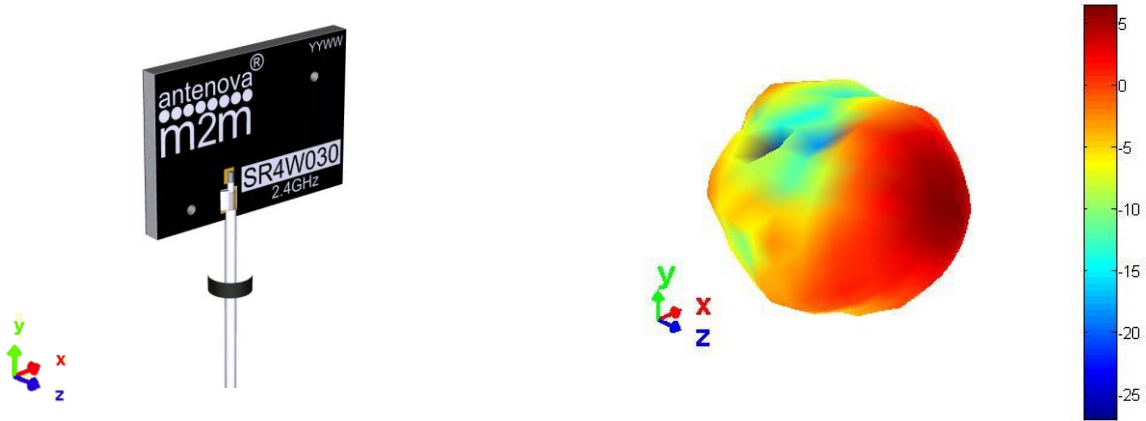

**3D pattern at 2450MHz**  
*Drag to rotate pattern and PCB by using Adobe Reader  
(Click to Activate)*

XY

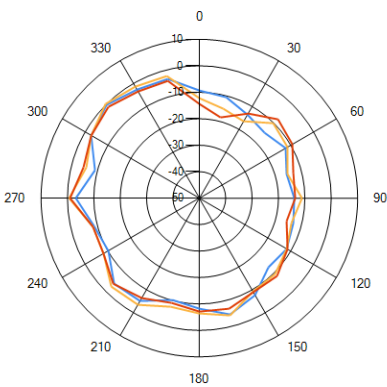

XZ

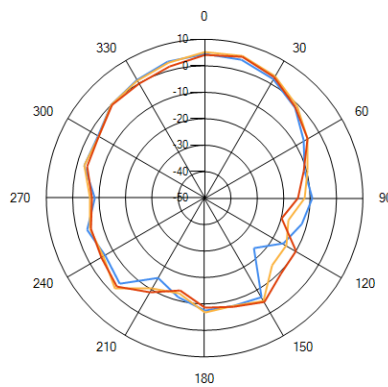

YZ

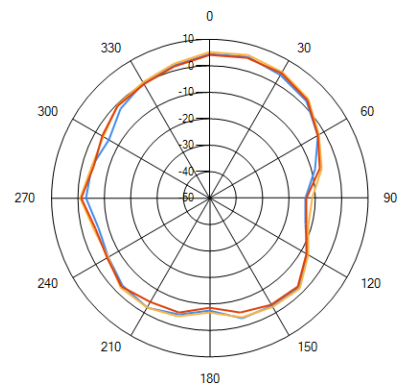

— 2.4GHz — 2.45GHz — 2.5GHz

## 8. Antenna Dimensions

### 8.1 Dimensions Antenna section

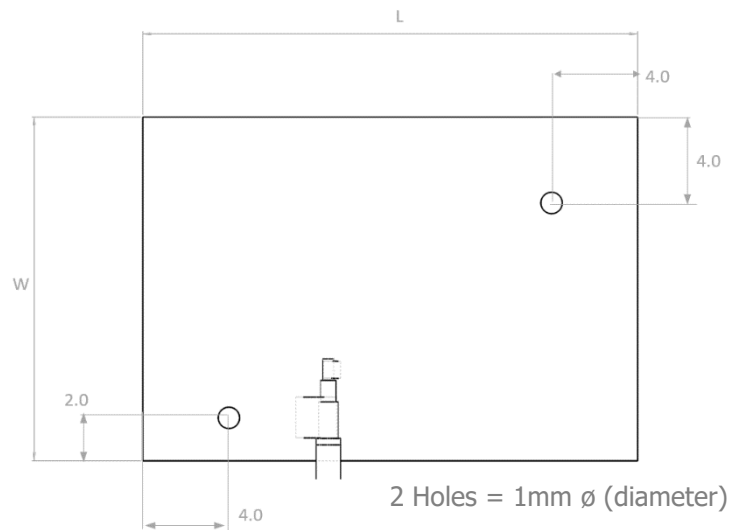

L	W	T
Length	Width	Thickness
23.0 $\pm$ 0.2 (mm)	16.0 $\pm$ 0.2 (mm)	1.6 (mm) nominal

All dimensions in mm

### 8.2 Dimensions assembled

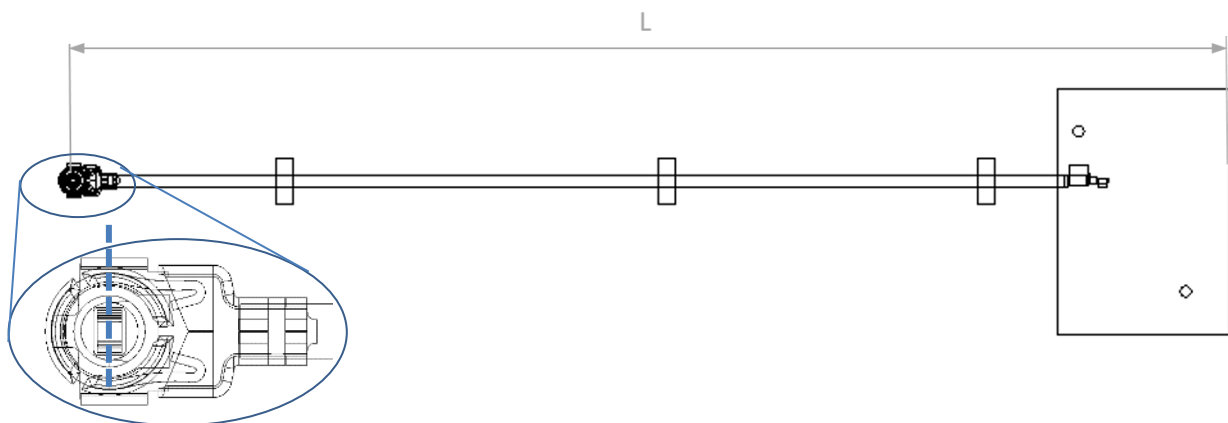

SR4W030-100	SR4W030-150
L	L
111 $\pm$ 2.0 (mm)	161 $\pm$ 2.0 (mm)

Antennas for Wireless M2M Applications

### 8.3 IPEX Connector

I-PEX	
Material	Copper Alloy
Plating	Ag

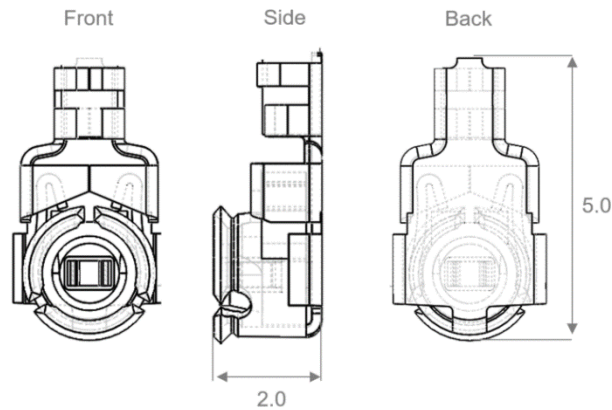

All dimensions in mm

### 8.4 O-Ring Spacer

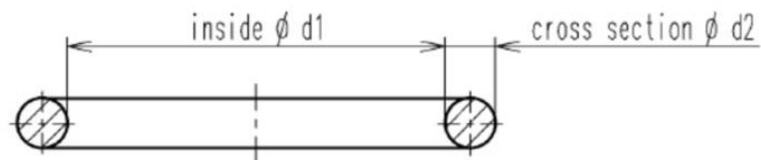

d1	d2
1.02 ±0.1	1.78 ±0.08

All dimensions in mm

## 8.4 Assembly

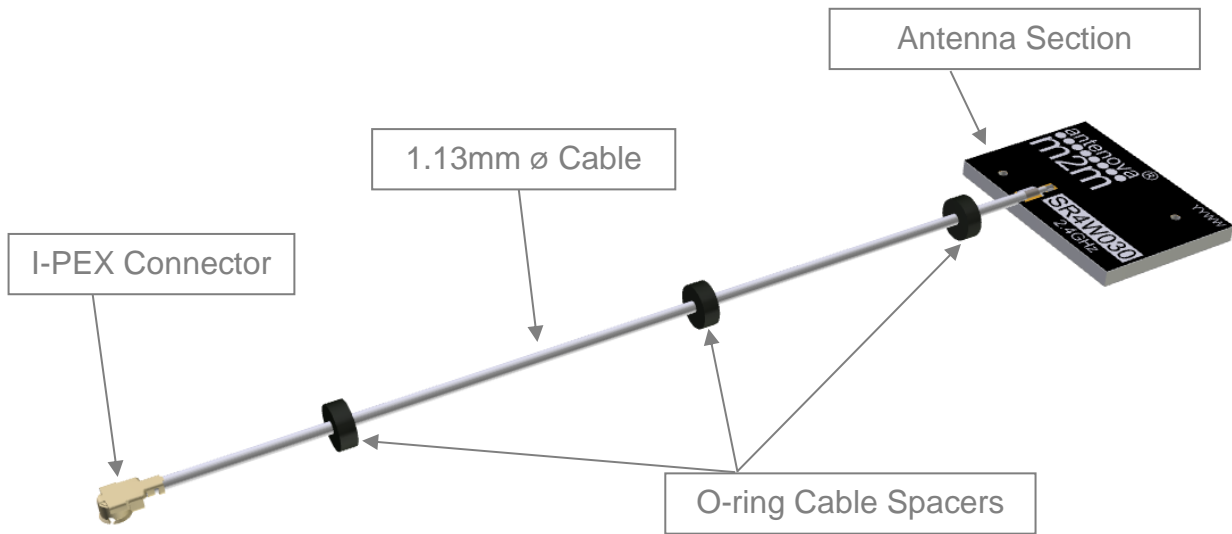



## 9. Electrical Interface

### 9.1 Host Interface

The host PCB requires the mating connector which is the IPEX MHF (UFL) receptacle. The location should be close to the chip/modules pin for the RF. Any feed from this receptacle should be maintained at 50Ω impedance.

### 9.2 Transmission Line

All transmission lines should be designed to have a characteristic impedance of 50Ω.

- The length of the transmission lines should be kept to a minimum
- Any other parts of the RF system like transceivers, power amplifiers, etc, should also be designed to have an impedance of 50 Ω.

Once the material for the PCB has been chosen (PCB thickness and dielectric constant), a coplanar transmission line can easily be designed using any of the commercial software packages for transmission line design. For the chosen PCB thickness, copper thickness and substrate dielectric constant, the program will calculate the appropriate transmission line width and gaps on either side of the feed.

A DC blocking capacitor should be placed in line to protect the RF front end.

## 10. Mechanical Adhesion

The antenna uses 3M 468MP adhesive on the reverse side of the antenna section. It is designed for a one time fix to a clean smooth surface.

*Antenna section reverse side*



## 11.0 Antenna Integration Guide

### 11.1 Applied Surface Material

The antenna can be placed on any material and will radiate effectively in the direction away from the material. The performance will vary depending on the type of material or surface applied. This antenna is intended for use internal to a device and this simply illustrates the versatility of the antenna.

The material behind the antenna is not critical and can enable proximity for devices that are thin and placed on a variety of surfaces.

Examples:

- Wall mounted devices.
- Mounting onto metal chassis (e.g. Light switch chassis)
- Direct to host PCB
- Devices installed in places where the material is not defined or could be any of the above.



## 11.2 Placement

For placing the antenna within a device, the host PCB size is not a factor as it is with PCB mounted antennas. Placement still needs to follow some basic rules, as any antenna is sensitive to its environment.

The top side of the antenna must be clear of all obstructions that are electrically conductive.

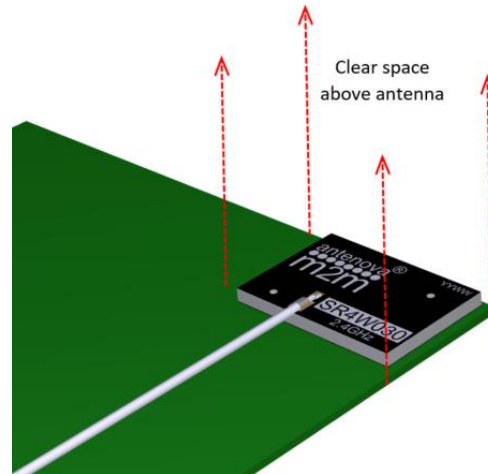

The location within a device will should ideally be along any outer edge. The height to any surface can be direct contact.

If placed on to a PCB, the proximity to any other board mounted component should be kept a minimum distance away. This distance can be defined from projecting a 5° angle from the bottom of the antenna as shown below.

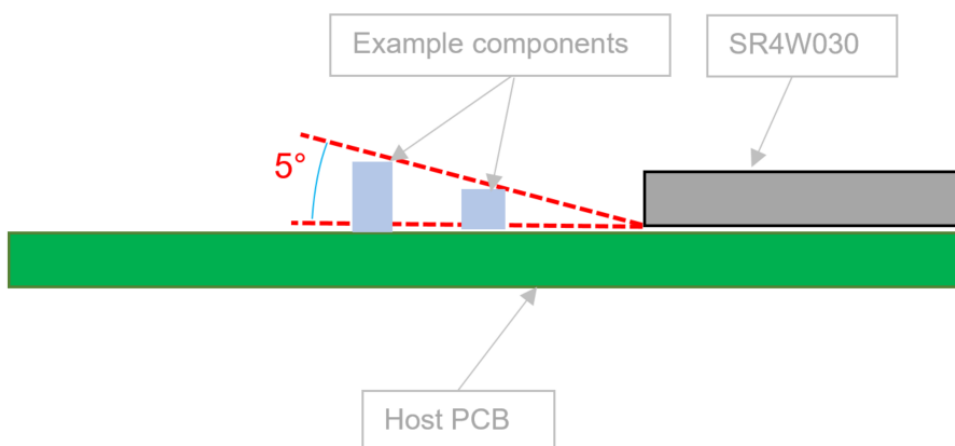

### 11.3 Cable Routing

The cable has 3 spacers to keep the clearance from any surface being in direct contact. Where 'd' is defined by the O-ring ( $d=1.78\text{mm}$ ).

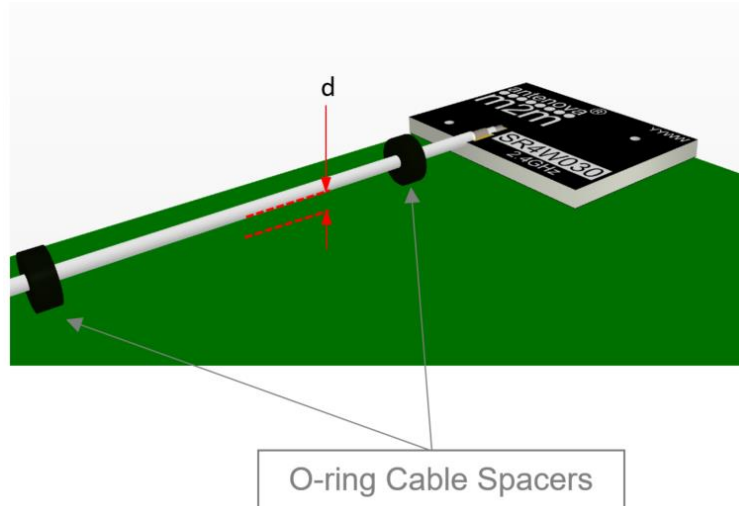

### 11.3 Evaluation Kit

The Reflector antenna EVK is available. This contains antenna samples and an evaluation PCB with 3 sections that can demonstrate the various placement options.

#### REFLECTOR-EVB-1 Evaluation Board

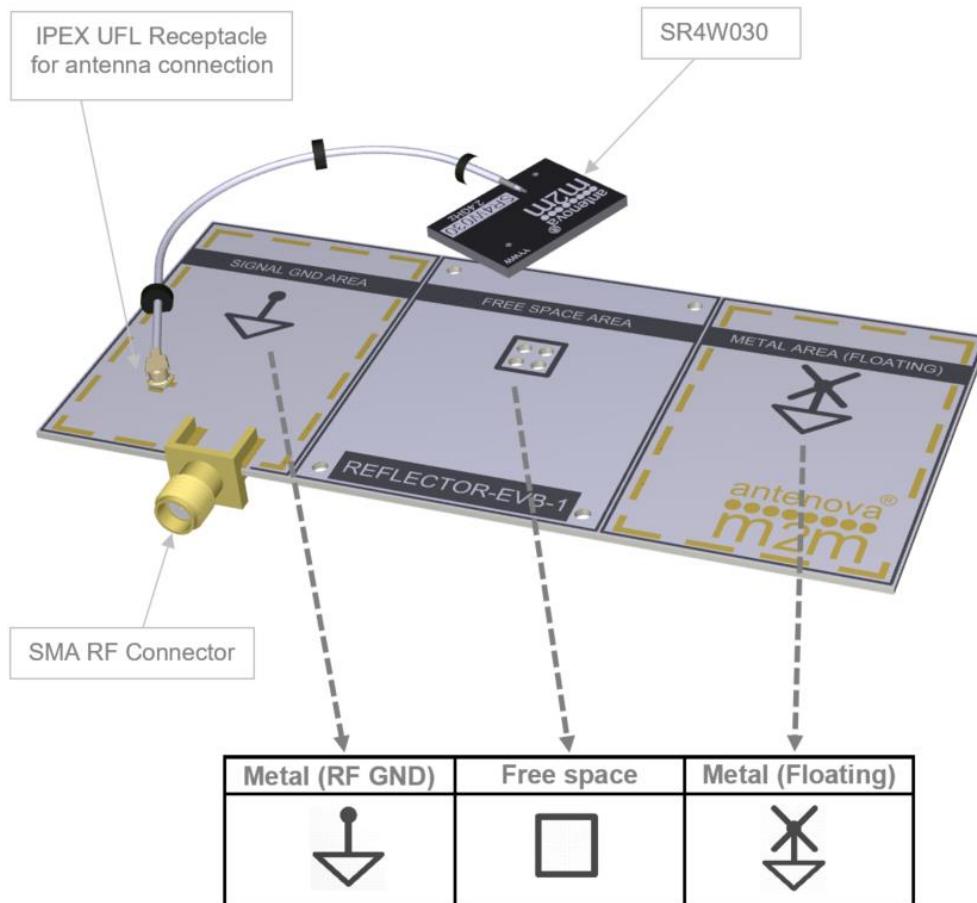

Dimensions: 110 x 50 (mm)

To order a reference board contact [sales@antenna-m2m.com](mailto:sales@antenna-m2m.com). Please state if a single antenna or two antenna EVB is required.

## 12. Hazardous Material Regulation Conformance

The antenna has been tested to conform to RoHS requirements. A certificate of conformance is available from Antenova M2M's website.

## 13. Packaging

The antennas are stored in individual plastic (PE) bags. Then stored within a second bag of 100pcs.

*Single antenna per bag*

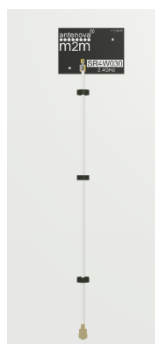

*100 units per second bag (Labelled)*

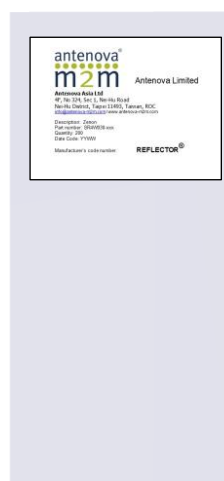

### 13.1 Optimal Storage Conditions

Temperature	-10°C to 40°C
Humidity	Less than 75% RH
Shelf life	18 Months
Storage place	Away from corrosive gas and direct sunlight
Packaging	Antennas should be stored in unopened sealed manufacturer's plastic packaging.

## 13.2 Label Information

