

## 1500 W, 50 V, HF to 500 MHz RF power LDMOS transistor

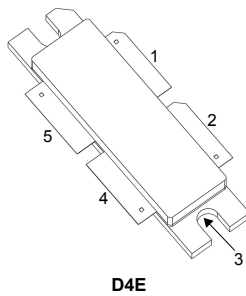

D4E

Pin connection	
Pin	Connection
1	Drain A
2	Drain B
3	Source (bottom side)
4	Gate B
5	Gate A



### Product status link

[RF5L051K5CB4](#)

### Product summary

<b>Order code</b>	RF5L051K5CB4
<b>Marking</b>	5L051K5
<b>Package</b>	D4E
<b>Packing</b>	Tray
<b>Base/bulk quantity</b>	20/100

### Features

Order code	Frequency	V <sub>DD</sub>	P <sub>OUT</sub>	Gain	Efficiency
RF5L051K5CB4	108 MHz	50 V	1500 W	22 dB	80%

- High efficiency and linear gain operations
- Integrated ESD protection
- Large positive and negative gate-source voltage range for improved class C operation
- On chip RC network enable high stability and ruggedness
- Excellent thermal stability, low HCI drift
- In compliance with the european directive 2002/95/EC

### Applications

- 30-88 MHz/136-174 MHz ground communication
- 1.6-30 MHz HF transceiver
- Plasma generator
- Particle accelerator
- FM and VHF TV broadcast

### Description

The **RF5L051K5CB4** is a 1500 W, 50 V, high performance, unmatched LDMOS FET, designed for wideband commercial and industrial applications in the frequency range from HF to 500 MHz. It can be used for both CW and pulse application. It is featured for high power and high ruggedness, suitable for industrial, scientific and medical application, as well as FM radio, VHF TV and aerospace applications.

# 1 Electrical ratings

**Table 1. Absolute maximum ratings ( $T_C = 25\text{ °C}$ )**

Symbol	Parameter	Value	Unit
$V_{DS}$	Drain-source voltage	110	V
$V_{GS}$	Gate-source voltage	-8 to 10	V
$V_{DD}$	Maximum operating voltage	55	V
$T_{STG}$	Storage temperature range	-65 to 150	°C
$T_J$	Maximum junction temperature	200	°C

**Table 2. Thermal data**

Symbol	Parameter	Value	Unit
$R_{thJC}^{(1)}$	Thermal resistance, junction-to-case	0.09	°C/W

1.  $T_C = 80\text{ °C}$ ,  $P_{OUT} = 1500\text{ W}$ , CW, DC test.

**Table 3. ESD protection**

Symbol	Test methodology	Class
HBM	Human body model (according to ANSI/ESDA/JEDEC JS001-2017 )	2
CDM	Charge device model (according to ANSI/ESDA/JEDEC JS002-2014)	C3

## 2 Electrical characteristics

**Table 4. Static (per side)**

Symbol	Parameter	Test conditions	Min.	Typ.	Max.	Unit
$V_{(BR)DSS}$	Drain-source breakdown voltage	$V_{GS} = 0\text{ V}, I_D = 100\ \mu\text{A}$	110			V
$I_{DSS}$	Zero gate voltage drain leakage current	$V_{GS} = 0\text{ V}, V_{DS} = 50\text{ V}$			1	$\mu\text{A}$
		$V_{GS} = 0\text{ V}, V_{DS} = 90\text{ V}$			1	
$I_{GSS}$	Gate-source leakage current	$V_{GS} = -8/10\text{ V}, V_{DS} = 0\text{ V}$			$\pm 100$	nA
$V_{GS(th)}$	Gate threshold voltage	$V_{DS} = 50\text{ V}, I_D = 600\ \mu\text{A}$	2.3		2.9	V
$V_{GS(Q)}$	Gate quiescent voltage	$V_{DS} = 50\text{ V}, I_D = 70\text{ mA}$		3.05		V
$V_{DS(on)}$	Static drain-source on-voltage	$V_{GS} = 10\text{ V}, I_D = 5\text{ A}$			450	mV
$I_{DS(on)}$	Static drain-source on-current	$V_{GS} = 10\text{ V}, V_{DS} = 100\text{ mV}$			2.5	A
$R_{DS(on)}$	Drain-source on-state resistance	$V_{GS} = 10\text{ V}, V_{DS} = 100\text{ mV}$			1	$\Omega$
$C_{iss}$	Common source input capacitance	$V_{GS} = 0\text{ V}, V_{DD} = 50\text{ V}, f = 1\text{ MHz}$		520		pF
$C_{rss}$	Common source feedback capacitance			1.4		pF
$C_{oss}$	Common source output capacitance			143		pF

**Table 5. Dynamic**

Symbol	Parameter	Test conditions	Min.	Typ.	Max.	Unit
f	Frequency				500	MHz
$P_{OUT}$	Output power	f = 108 MHz, 3 dB compression	-	1500		W
$G_{PS}$	Power gain		-	22		dB
$\eta_D$	Drain efficiency		-	80		%
VSWR	Load mismatch	$P_{OUT} = 1500\text{ W}$ , all phases	-		10:1	

Note:  $V_{DD} = 50\text{ V}, I_{DQ} = 200\text{ mA}$ , pulsed CW, pulse width = 100  $\mu\text{s}$ , duty cycle = 10%.

### 3 Typical performances

Figure 1. Power gain and drain efficiency vs output power (f = 108 MHz)

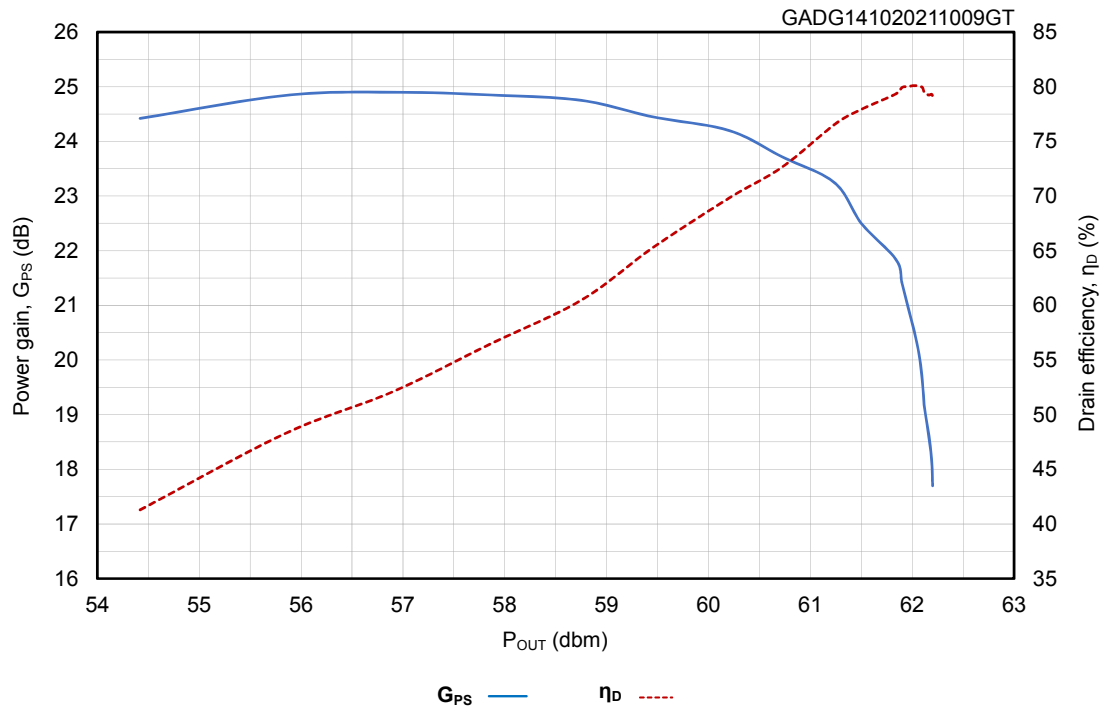

Note:  $V_{DD} = 50\text{ V}$ ,  $I_{DQ} = 200\text{ mA}$ , pulsed CW, pulse width = 100 μs, duty cycle = 10%.

## 4 Test circuits

Figure 2. Test circuit layout (f = 108 MHz)

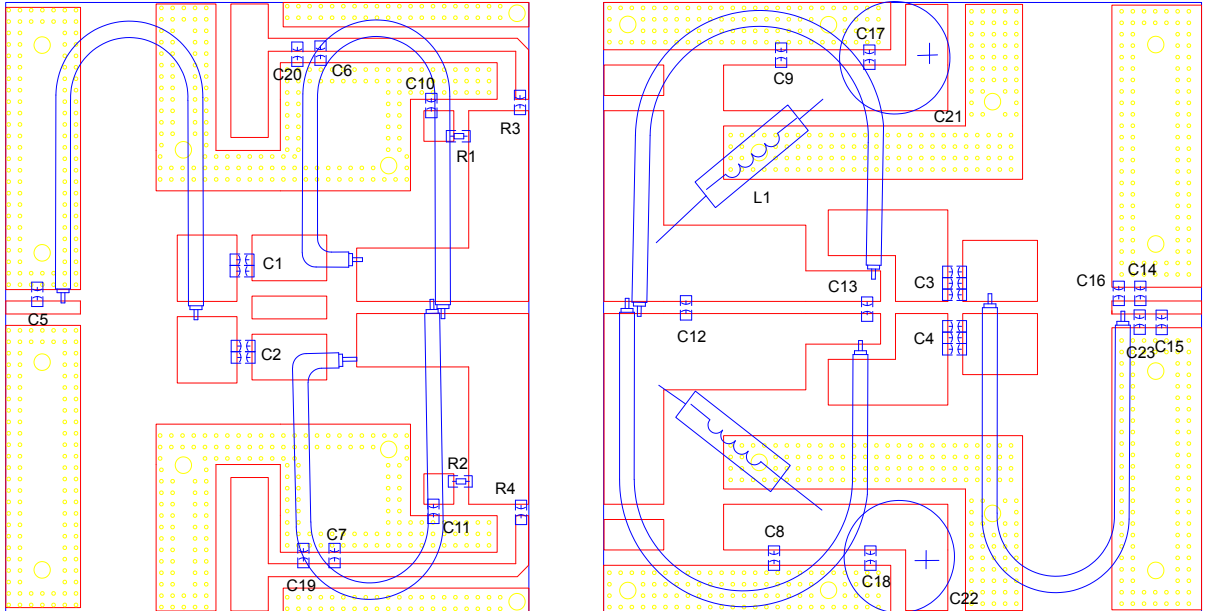

GADG12052021112GT

Figure 3. Test circuit photo

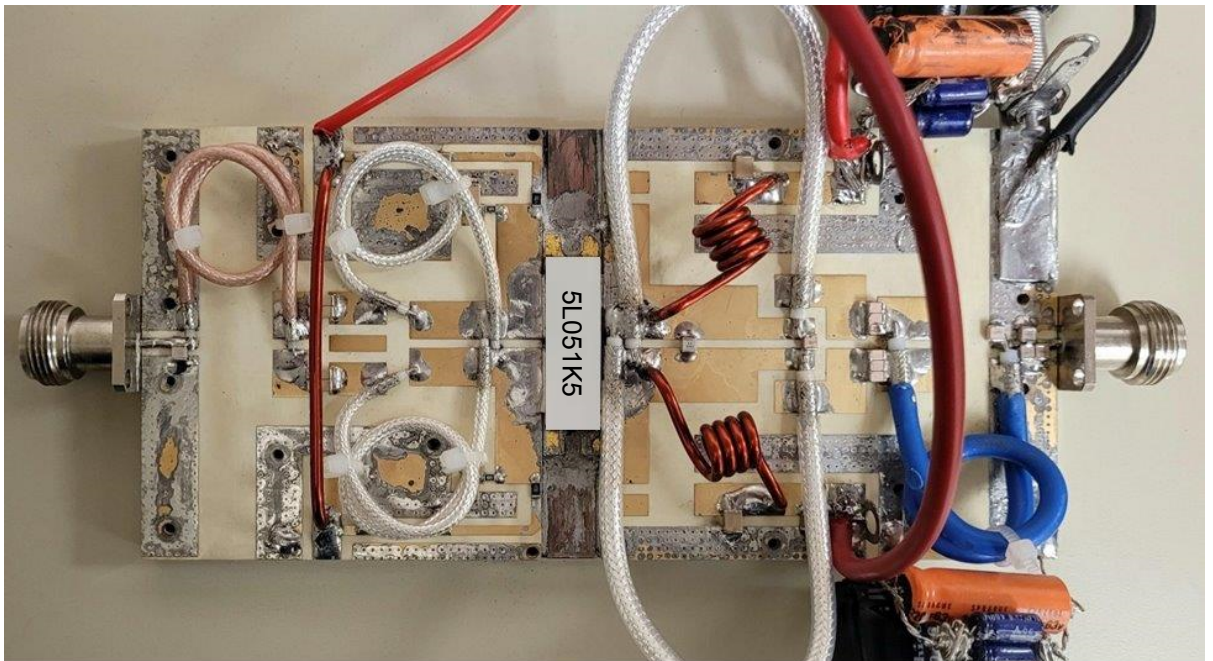

GADG141020211026GT

**Table 6. Components list**

Component	Value	Reference
C1, C2	470 pF (2x)	ATC800B
C3, C4	470 pF (3x)	ATC800B
C5	33 pF	DLC70B
C6, C7, C8, C9, C10, C11	100 nF	C4532X7R3D103KT000N
C12, C13	20 pF	DLC70B
C14, C15, C16, C23	3.9 pF	DLC70B
C17, C18, C19, C20	10 $\mu$ F	100 V ceramic capacitor
C21, C22	2200 $\mu$ F	63 V electrolytic capacitor
R1, R2	16 $\Omega$	0805 chip resistor
R3, R4	470 $\Omega$	0805 chip resistor
T1	50 $\Omega$ , 150 mm	SFF-50-1.5
T2, T3	25 $\Omega$ , line length = 150 mm, 9:1	SFF-25-1.5
T4, T5	12.5 $\Omega$ , line length = 150 mm, 9:1	SFF-12.5-1.5
T6	50 $\Omega$ , 150 mm	RG402-3
L1, L2	4 turns, $\Phi$ 1 mm	
PCB	0.762 mm (0.030") thick, $\epsilon_r = 3.48$ , Rogers RO4350B, 1 oz. copper	

## 5 Package information

In order to meet environmental requirements, ST offers these devices in different grades of **ECOPACK** packages, depending on their level of environmental compliance. ECOPACK specifications, grade definitions and product status are available at: [www.st.com](http://www.st.com). ECOPACK is an ST trademark.

### 5.1 D4E package information

Figure 4. D4E package outline

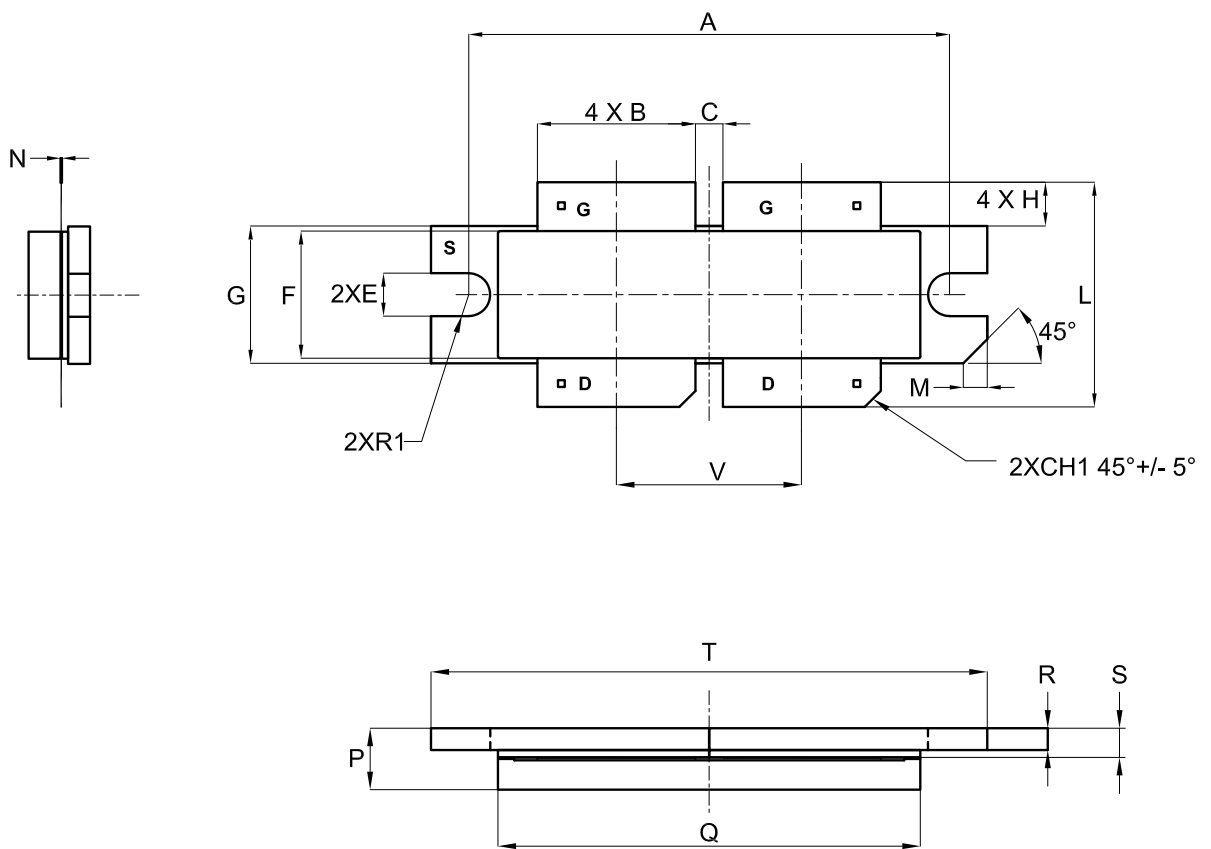

DM0066713\_2

**Table 7. D4E package mechanical data**

Symbol	Millimeters		
	Min.	Typ.	Max.
A	35.44	35.56	35.68
B	11.56	11.68	11.80
C	1.92	2.04	2.16
E	3.06	3.18	3.30
F	9.25	9.40	9.50
G	10.04	10.16	10.28
H	5.72	5.85	3.48
L	16.11	16.62	17.13
M	1.51	1.78	2.05
N	0.10	0.13	0.16
P	4.17	4.55	4.93
Q	30.96	31.24	31.52
R	1.55	1.62	1.69
S	2.09	2.16	2.23
T	41.08	41.22	
V	13.60	13.72	13.84
R1		1.59	
CH1		1.19	



## 5.2 Marking information

Figure 5. Marking composition

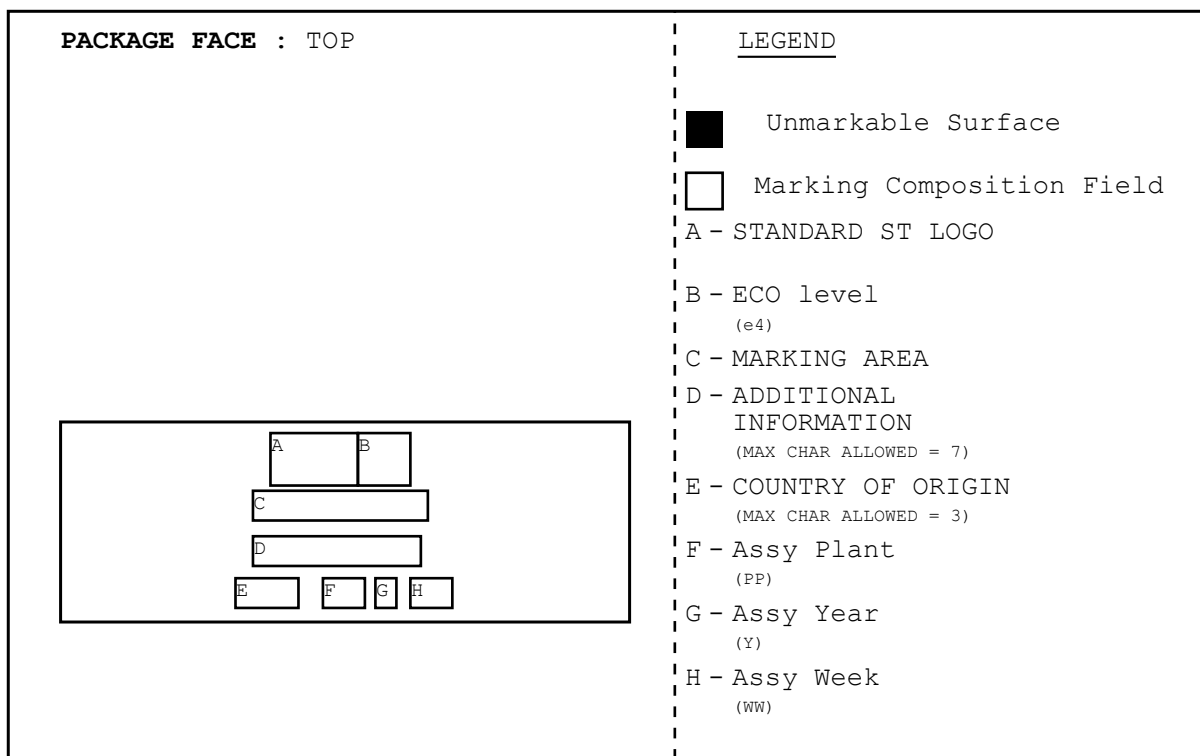

GADG040220211644GT

## Revision history

**Table 8. Document revision history**

Date	Version	Changes
25-May-2021	1	First release.
14-Oct-2021	2	Updated <a href="#">Features and Description</a> on cover page. Updated <a href="#">Table 1. Absolute maximum ratings</a> ( $T_C = 25\text{ °C}$ ). Updated <a href="#">Section 2 Electrical characteristics</a> . Added <a href="#">Section 3 Typical performances</a> . Updated <a href="#">Figure 3. Test circuit photo</a> and <a href="#">Table 6. Components list</a> .

---

## Contents

<b>1</b>	<b>Electrical data</b> .....	<b>2</b>
<b>2</b>	<b>Electrical characteristics</b> .....	<b>3</b>
<b>3</b>	<b>Typical performances</b> .....	<b>4</b>
<b>4</b>	<b>Test circuits</b> .....	<b>5</b>
<b>5</b>	<b>Package information</b> .....	<b>7</b>
<b>5.1</b>	<b>D4E package information</b> .....	<b>7</b>
<b>5.2</b>	<b>Marking information</b> .....	<b>9</b>
	<b>Revision history</b> .....	<b>10</b>