

RFFM6909

925MHz Transmit/Receive Module

This module is intended for 868MHz and 915MHz AMR solutions. The FEM provides separate ports for Rx/Tx paths, single-ended Tx and single-ended Rx or Rx differential port, 14dB gain single stage LNA, and single port antenna connection. The PA switch provides a nominal insertion loss of 0.8dB. The device is provided in a 4.0mm x 3.0mm, 18-pin package.



Package: LGA, 18-pin,
4.0mm x 3.0mm

Features

- Tx Insertion Loss: 0.7dB
- 50Ω Tx Transceiver Interface
- 75Ω Rx Differential Transceiver Interface
- Rx Gain: 14dB

Applications

- Wireless Automated Metering
- Wireless Alarm Systems
- Portable Battery Powered Equipment
- Smart Energy
- 925MHz ISM Band Application
- Single Chip RF Front End Module

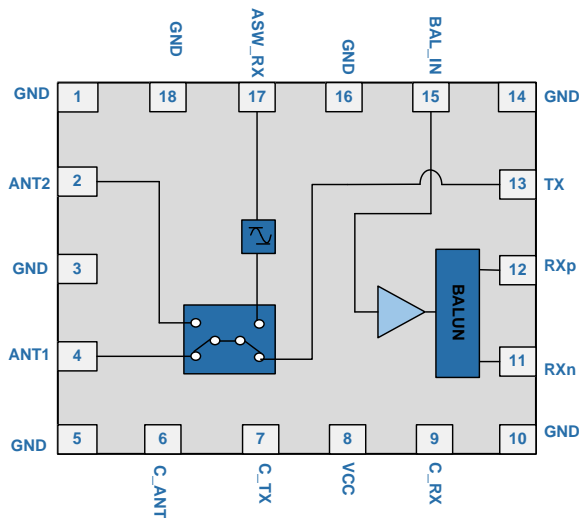

Functional Block Diagram

Ordering Information

RFFM6909SB	Standard 5-piece bag
RFFM6909SQ	Standard 25-piece bag
RFFM6909SR	Standard 100-piece reel
RFFM6909TR13	Standard 2500-pieces reel
RFFM6909PCK-410	Fully assembled eval board w/5-piece sample bag

Absolute Maximum Ratings

Parameter	Rating	Unit
Battery Voltage	5.5	V
Operating Temperature	-40 to 85	°C
Storage Temperature	-40 to 150	°C
ESD, HBM (all pins)	1000	V
ESD, CDM (all pins)	1000	V
MSL	MSL 3	
Maximum Input Power to TX Port	+25	dBm
Maximum Input Power to ANT1/ANT2 Switch	+20	dBm
Maximum Input Power to BAL_IN	+10	dBm



Caution! ESD sensitive device.



RFMD Green: RoHS status based on EU Directive 2011/65/EU (at time of this document revision), halogen free per IEC 61249-2-21, < 1000ppm each of antimony trioxide in polymeric materials and red phosphorus as a flame retardant, and <2% antimony in solder.

Exceeding any one or a combination of the Absolute Maximum Rating conditions may cause permanent damage to the device. Extended application of Absolute Maximum Rating conditions to the device may reduce device reliability. Specified typical performance or functional operation of the device under Absolute Maximum Rating conditions is not implied.

Nominal Operating Parameters

Parameter	Specification			Unit	Condition
	Min	Typ	Max		
Frequency	922	925	929	MHz	
RF Port Impedance		50		Ω	Single-ended
		75		Ω	Balanced; RX_P and RX_N
Operating Temperature	-40		85	°C	
Storage Temperature	-40		150	°C	
Total Leakage Current		1	10	μA	
RX Section					V_{CC} = 3.6V, C_{TX} = 0V, C_{RX} = 3.4V, Temperature = 25°C; Unless otherwise specified.
Battery Voltage	3.3	3.6	4.0	V	V _{CC}
RX Gain	12	14	16	dB	
Noise Figure		1.5	2	dB	
Input IP3		1		dBm	
Input Return Loss	7	10		dB	
Output Return Loss	10	15		dB	
LNA Current	6	8	12	mA	Over all conditions
V _{CC} RX Quiescent Current		9		mA	
Amplitude Imbalance	-0.6		+0.6	dB	BAL_IN to RX_N/RX_P
Phase Imbalance	-10		+10	Deg	
Antenna Switch Section					
Isolation		25		dB	Any used port to any unused port
TX Insertion Loss		0.7	1.2	dB	Pins 2, 4 to Pins 13
RX Insertion Loss		1.0	1.5	dB	Pins 2, 4 to Pins 17
Logic Voltage, High	3.1	3.4	3.8	V	All Logic I/Os, V _{BAT} -0.2V
Logic Voltage, Low	0.0		0.2	V	All Logic I/Os
Logic Current, High		5	10	μA	
Logic Current, Low		0.4		μA	

Switch Control Truth Table

Operating Mode	C_TX	C_RX	C_ANT
TX-ANT1	1	0	0
TX-ANT2	1	0	1
RX-ANT1	0	1	0
RX-ANT2	0	1	1
All Off	0	0	0

Note:

*Switch Control Logic High=Min 3.1V to Max 3.8V

*Switch Control Logic Low= 0.0V to Max 0.2V

Pin Out

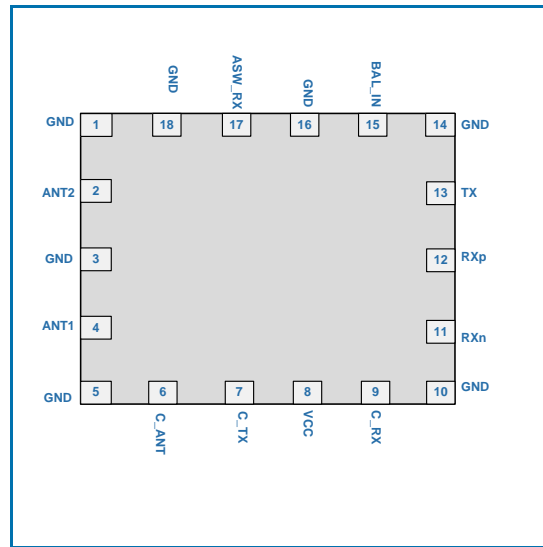

Package Outline and Branding Drawing (Dimensions in millimeters)

