

Product Overview

The RFGA2054 is a high performance InGaP HBT MMIC amplifier. The RFGA2054's internal active bias circuitry allows the amplifier to operate directly from a 5V supply and provides stable current over temperature and process variations of the Beta. This Darlington amplifier is internally matched to 50Ω making it ideal for applications requiring small footprints and minimal external components.



SOT-89 Package

Key Features

- Low Cost
- Broadband Gain
- Internally Matched
- Internal Active Bias
- No Dropping Resistor Required
- Single Supply 5V Operation
- HBM ESD Level >1000V

Functional Block Diagram

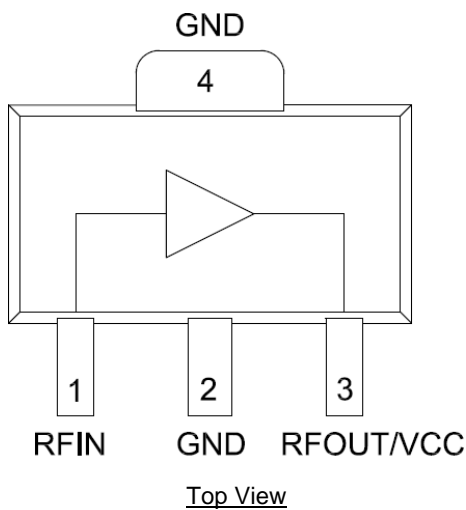

Applications

- PA Driver Amplifier
- LO Buffer Amplifier
- Cellular, PCS, GSM, UMTS, LTE, TD_SCDMA
- Wideband Instrumentation
- Wireless Data, Satellite Terminals

Ordering Information

Part No.	Description
RFGA2054TR13	2,500 pieces on a 13" reel
RFGA2054 PCK-410	500–3000 MHz Evaluation Board with a 5-piece sample bag

Absolute Maximum Ratings

Parameter	Rating
Storage Temperature	-55 to +150 °C
Device Voltage (V _{CC})	+6.0 V
Device Current (I _{CC})	130 mA
RF Input Power, CW, 50 Ω Output Load	+15 dBm
RF Input Power, CW, 10:1 Output VSWR	+10 dBm
Junction Temperature (T _J)	+150 °C

Exceeding any one or a combination of the Absolute Maximum Rating conditions may cause permanent damage to the device. Extended application of Absolute Maximum Rating conditions to the device may reduce device reliability.

Electrical Specifications

Parameter	Conditions ⁽¹⁾	Min	Typ	Max	Units
Linear Operation	Standard EVB circuit without R2				
Input Power	V _{CC} < 5.0V, Load VSWR < 2:1, R2 Open			3.0	dBm
Gain, Small Signal	850 MHz		20.3		dB
	2140 MHz	17.3	18.8	20.3	dB
	2650 MHz		18.4		dB
Input Return Loss	2140 MHz		13.0		dB
Output Return Loss			13.5		dB
Output P1dB	850 MHz		20.3		dBm
	2140 MHz	18.5	20.0		dBm
	2650 MHz		19.5		dBm
Output IP3 ⁽²⁾	850 MHz		33.5		dBm
	2140 MHz	28.0	30.5		dBm
	2650 MHz		29.0		dBm
Bandwidth	Minimum 10 dB typical return loss		3000		MHz
Reverse Isolation	2140 MHz		23.0		dB
Noise Figure			3.6		dB
Device Quiescent Current, I _{CC}	Pin 3		68	78	mA
Thermal Resistance, θ _{JC}	Junction to case at quiescent state no RF		135		°C/W
Saturated Operation	With R2 5.1KΩ Pin 1 and GND lowering ICQ				
Input Power	V _{CC} < 5.0V, Load VSWR < 2:1, R2=5.1 KΩ			10	dBm
Saturated Output Power	850 MHz		20.0		dBm
	2140 MHz		20.5		dBm
	2650 MHz		20.7		dBm
Operating Current, I _{CC}				90	mA

Notes:

1. Test conditions unless otherwise noted: V_{CC} = +5.0V, Temp = +25 °C, 50 Ω test system
2. P_{OUT} = 0 dBm/tone, Δf = 1 MHz

Recommended Operating Conditions

Parameter	Min	Typ	Max	Units
Device Voltage (V _{CC})		+5	+5.25	V
T _{CASE}	-40		+85	°C

Electrical specifications are measured at specified test conditions. Specifications are not guaranteed over all recommended operating conditions.

500MHz to 3500 MHz Evaluation Board – RFGA2054PCK-410

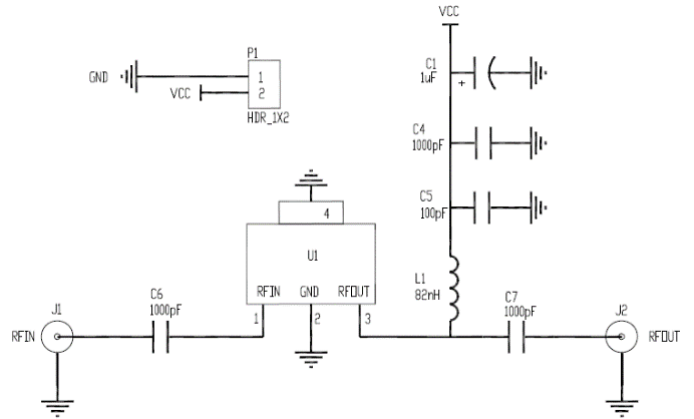
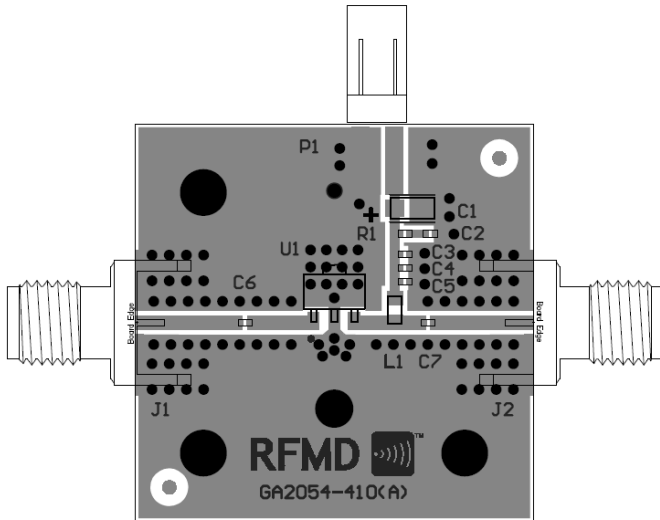

Bill of Material – RFGA2054PCK-410

Reference Des.	Value	Description	Manuf.	Part Number
PCB	-	Printed Circuit Board	Qorvo	-
U1	-	AMP, InGaP Darlington HBT, SOT-89	Qorvo	RFGA2054
C1	1 μ F	CAP, 1 μ F, 20%, 25V, TANT-A	AVX	TAJA105M025
C4, C6, C7	1000 pF	CAP, 1000 pF, 10%, 50V, X7R, 0402	Taiyo Yuden	RM UMK105BJ102KV-F
C5	100 pF	CAP, 100 pF, 5%, 50V, C0G, 0402	Taiyo Yuden	RM UMK105CG101JV-F
L1	82 nH	IND, 82 nH, 10%, W/W, 0805	Coilcraft	0805CS-820XKBC
J1, J2	-	CONN, SMA, END LNCH, FLT, 0.062"	Johnson	142-0701-821
P1	-	CONN, HDR, ST, PLRZD, 2-Pin, 0.100"	ITW Pancon	MPSS100-2-C

Linear Operation Performance Plots – RFGA2054PCK-410

Test conditions unless otherwise noted: $V_{CC} = +5V$, 50Ω test system, Temp.=+25 °C

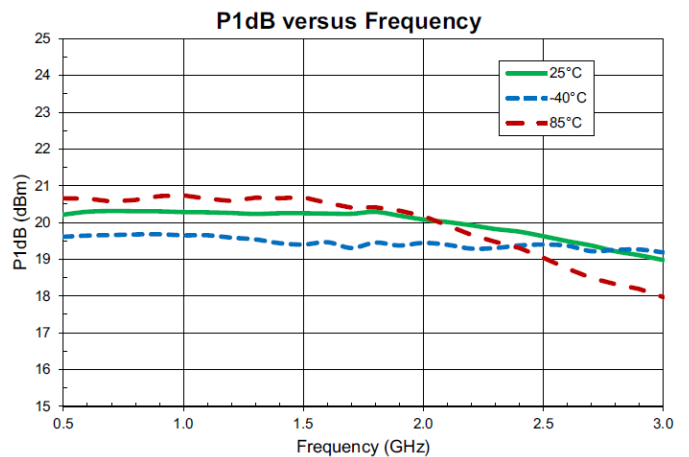
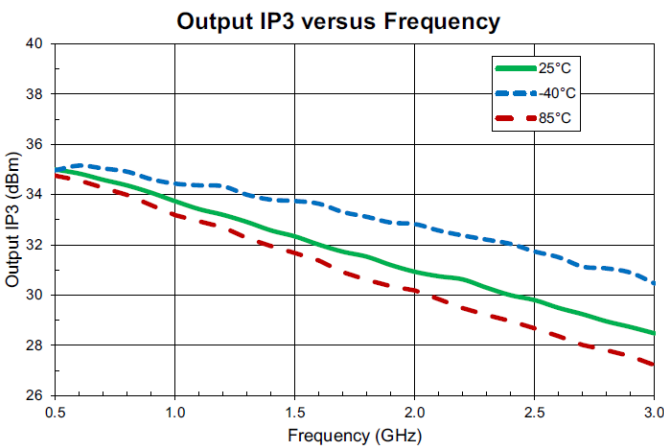
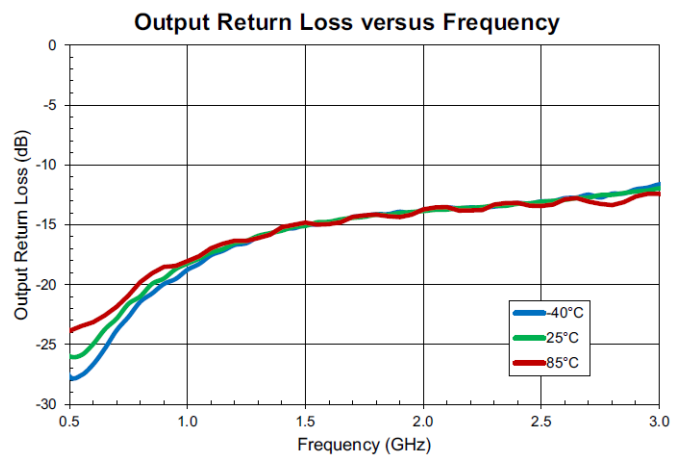
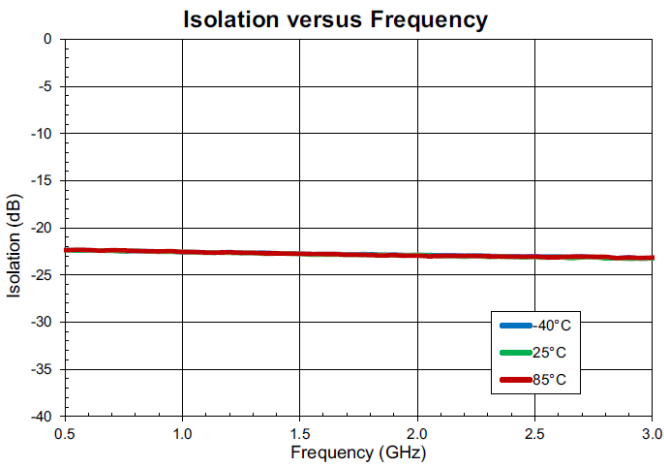
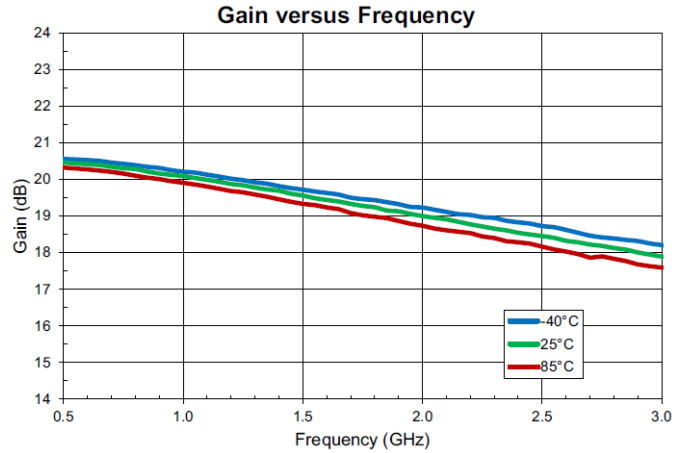
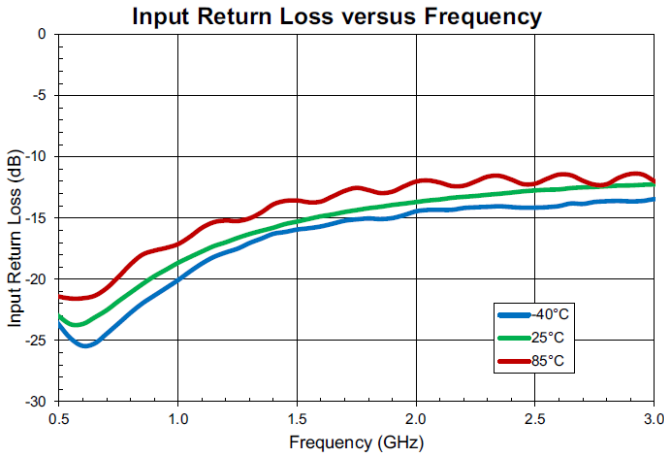

Linear Operation Performance Plots – RFGA2054PCK-410 (continued)

Test conditions unless otherwise noted: $V_{CC} = +5V$, 50Ω test system, Temp.=+25 °C

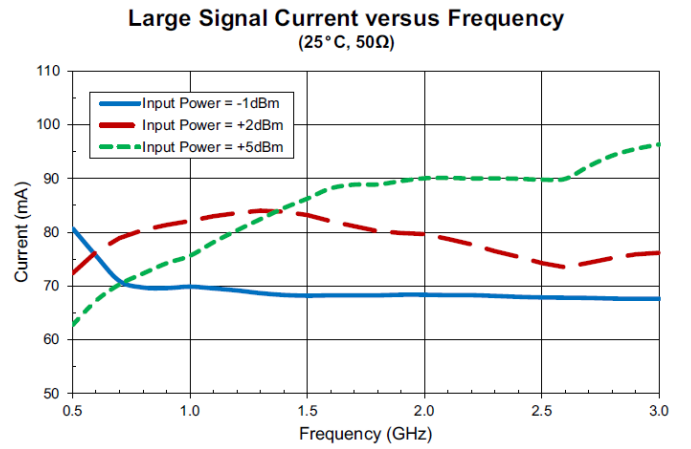
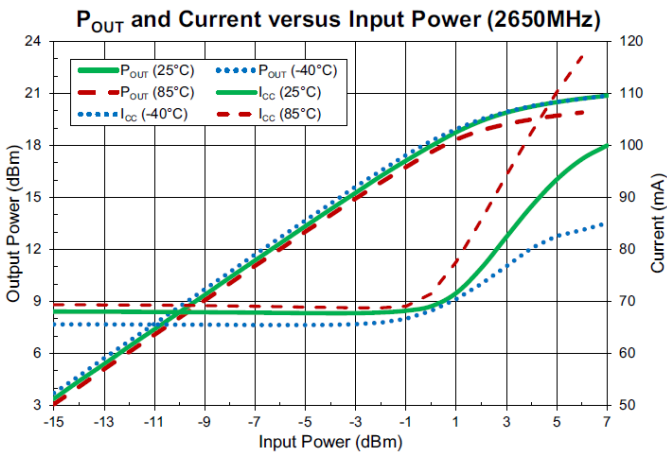
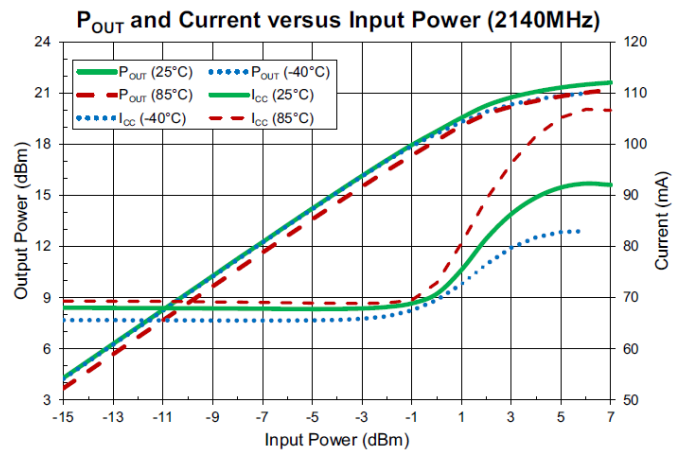
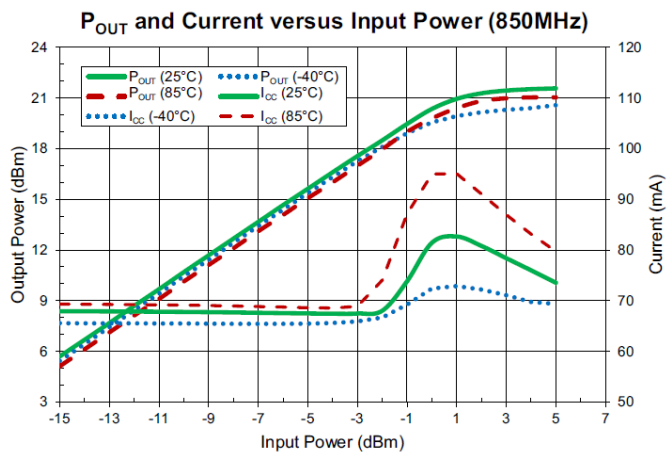
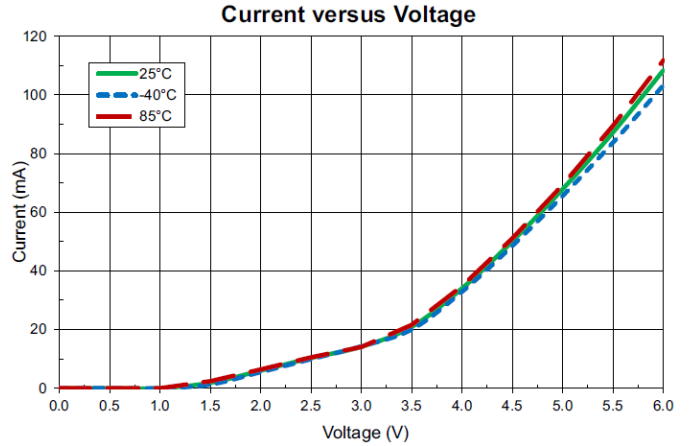
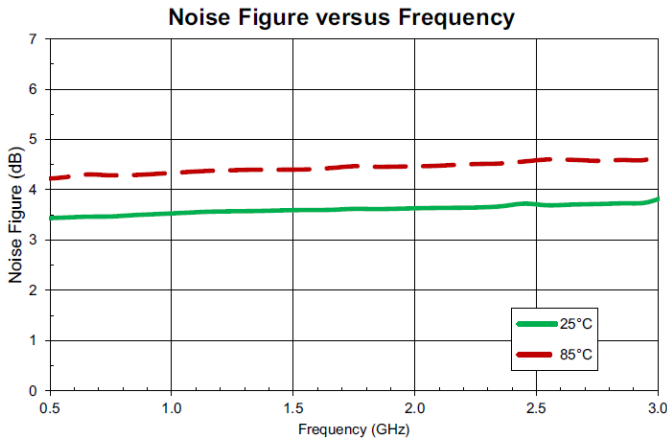

Saturated Application Board and Schematic

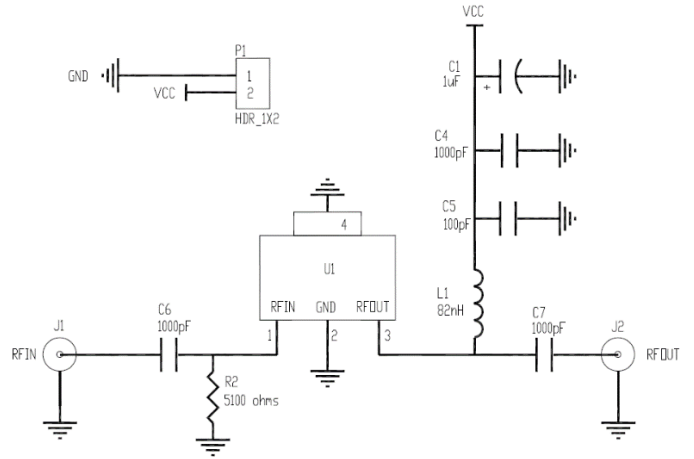
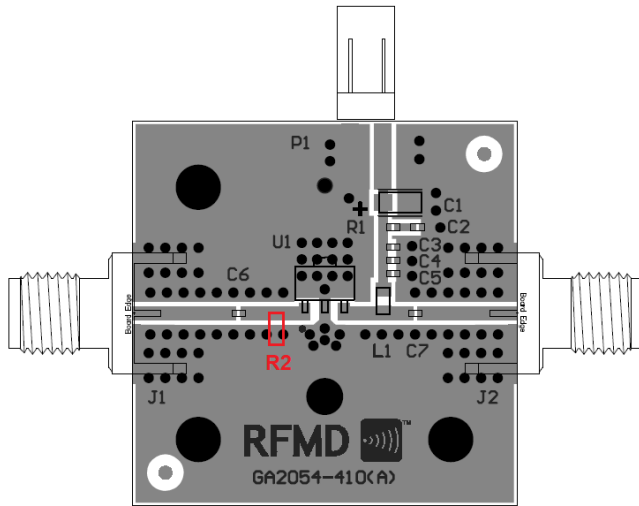

Additional resistor R2, 5.1KΩ, shunted to ground in between C6 and Pin 1

Saturated Performance Plots – with R2, 5.1KΩ

Test conditions unless otherwise noted: $V_{CC} = +5V$, 50 Ω test system, Temp. = +25 °C

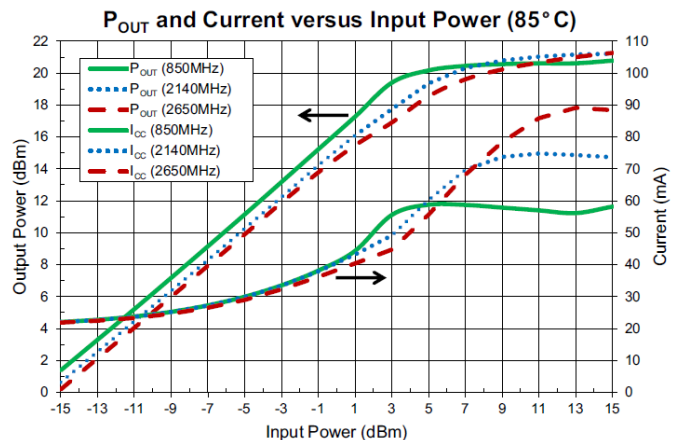
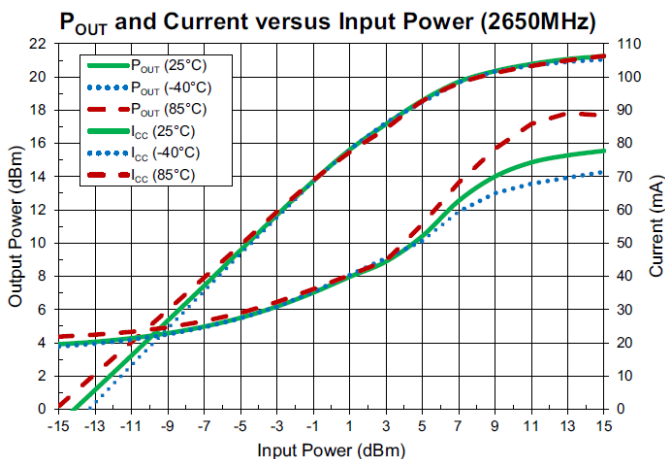
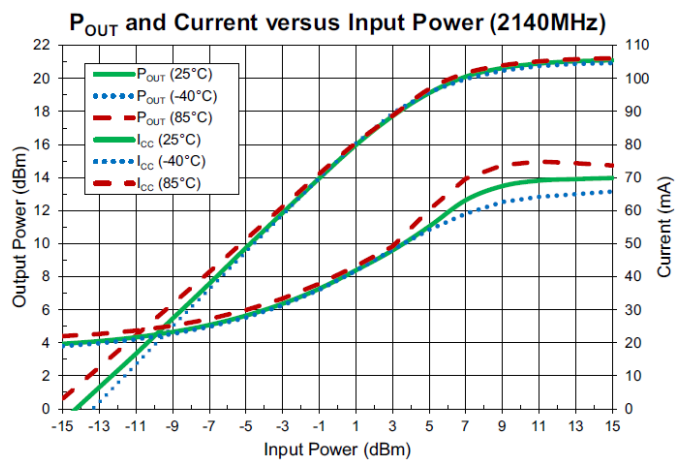
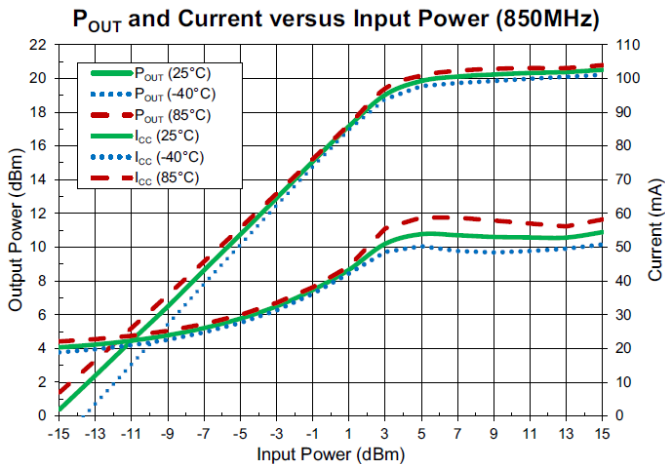

Pad Configuration and Description

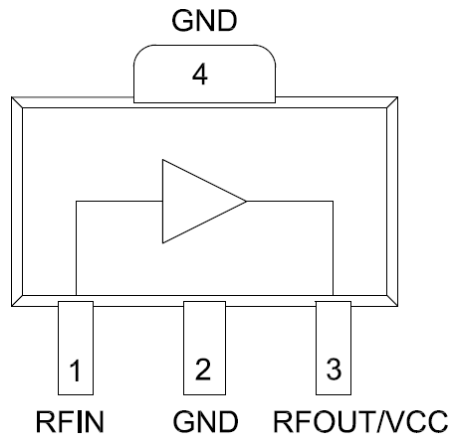

Top View

Pad No.	Label	Description
1	RFIN	RF input. External DC Block capacitor required.
3	RFOUT / VCC	RF output and DC Supply input. Device Collector, External DC Block capacitor required.
2, 4 Backside Paddle	GND	RF and DC ground. Use recommended via hole pattern to minimize inductance and thermal resistance. See PCB Mounting Pattern for suggested footprint.

Package Marking and Dimensions

Marking: Part Number – GA2054
 Trace Code – Assigned by sub-contractor

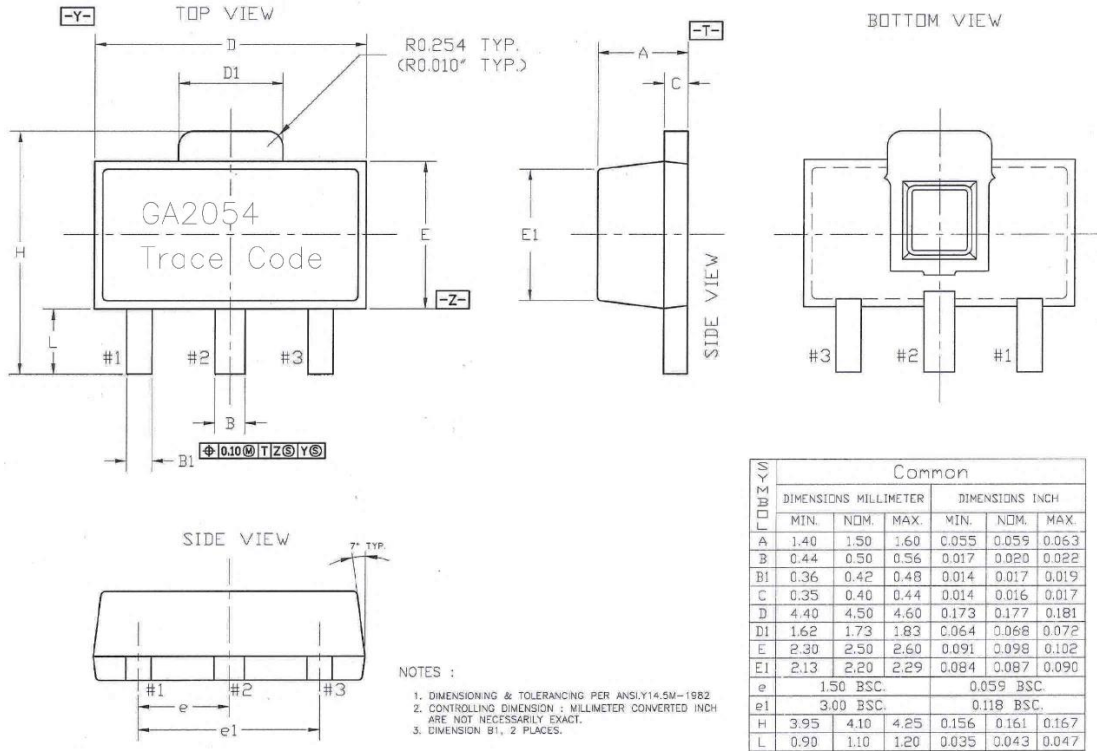

- Notes:
1. All dimensions are in millimeters. Angles are in degrees.
 2. The terminal #1 identifier and terminal numbering conform to JESD 95-1 SPP-012.

PCB Mounting Pattern

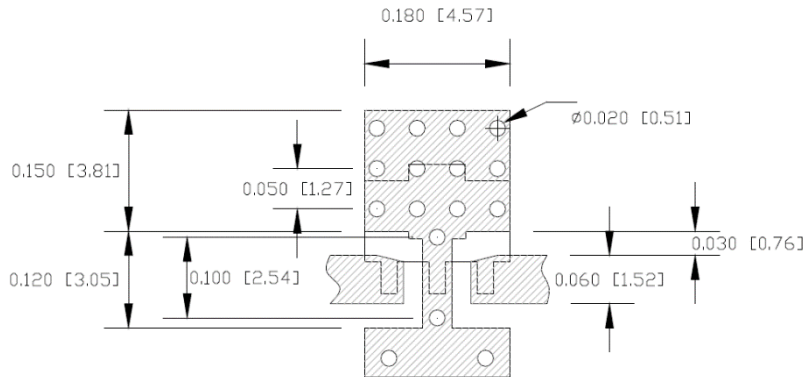

- Notes:
1. All dimensions are in millimeters. Angles are in degrees.
 2. Use 1 oz. copper minimum for top and bottom layer metal.
 3. Via holes are required under the backside paddle of this device for proper RF/DC grounding and thermal dissipation. We recommend a 0.35mm (#80/.0135") diameter bit for drilling via holes and a final plated thru diameter of 0.25 mm (0.01").
 4. Ensure good package backside paddle solder attach for reliable operation and best electrical performance.

Tape and Reel Information – Carrier and Cover Tape Dimensions

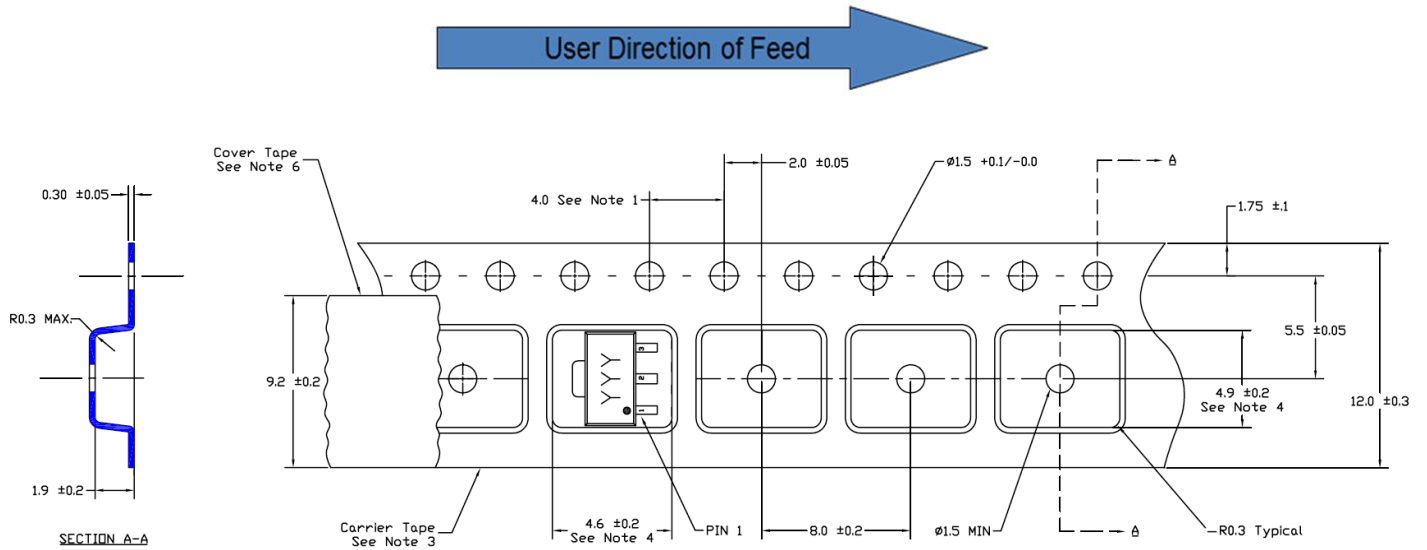

- 1. 10 sprocket hole pitch cumulative tolerance
- 2. Camber not to exceed 1mm in 100mm
- 3. Material: Black Conductive Polystyrene
- 4. Measured on a plane 0.3mm above the bottom of the pocket
- 5. Measured from a plane on the inside bottom of the pocket to the top surface of the carrier.
- 6. Material: Antistatic Polyester Film

Feature	Measure	Symbol	Size (in)	Size (mm)
Cavity	Length	A0	0.181	4.60
	Width	B0	0.193	4.90
	Depth	K0	0.075	1.90
	Pitch	P1	0.315	8.00
Centerline Distance	Cavity to Perforation - Length Direction	P2	0.079	2.00
	Cavity to Perforation - Width Direction	F	0.217	5.50
Cover Tape	Width	C	0.362	9.20
Carrier Tape	Width	W	0.472	12.0

Tape and Reel Information – Reel Dimensions

Standard T/R size = 2,500 pieces on a 13" reel.

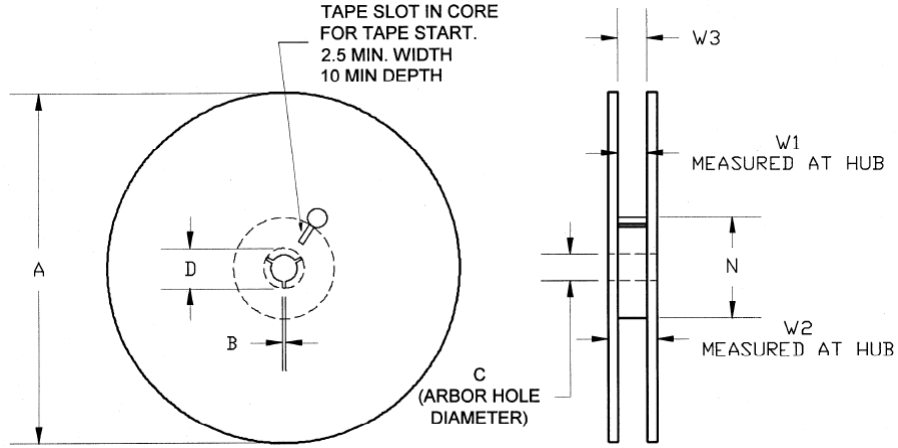

Feature	Measure	Symbol	Size (in)	Size (mm)
Flange	Diameter	A	12.992	330.0
	Thickness	W2	0.717	18.2
	Space Between Flange	W1	0.504	12.8
Hub	Outer Diameter	N	4.016	102.0
	Arbor Hole Diameter	C	0.512	13.0
	Key Slit Width	B	0.079	2.0
	Key Slit Diameter	D	0.787	20.0

Tape and Reel Information – Tape Length and Label Placement

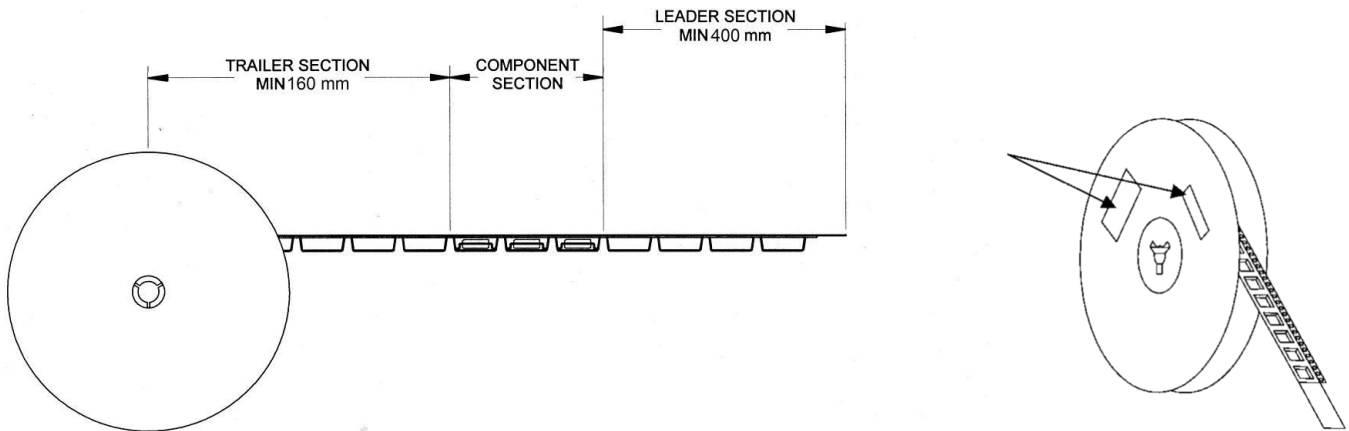

- Notes:
1. Empty part cavities at the trailing and leading ends are sealed with cover tape. See EIA 481-1-A.
 2. Labels are placed on the flange opposite the sprockets in the carrier tape.