

RTD60

Silicon-Based Thermopile Detector 60

The RTD60 is a single-channel silicon-based thermopile detector in a TO-5 package. The device offers a low-cost solution, with a small active area and fast response, with a time constant of 18ms with Nitrogen encapsulation gas.

Image Diagram

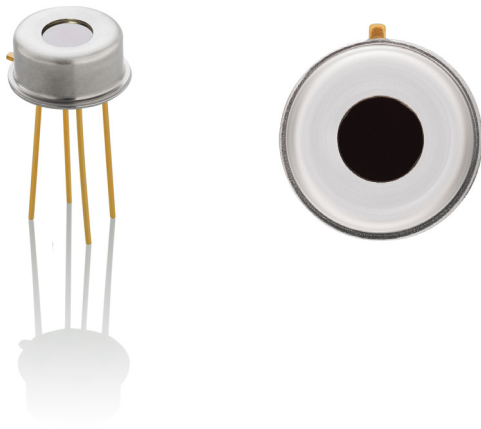

Features

- A single-channel silicon-based thermopile detector in a TO-5 package
- Four pin, 9.22mm TO-5 package
- Active area size is 0.61 × 0.61 mm
- Delivers a time constant of 18ms with Nitrogen encapsulation gas
- Very low Temperature Coefficient of Responsivity of -0.04%/°C
- Very short thermal shock response to ambient temperature change
- Internal 5% NTC chip thermistor provides ambient package temperature measurement
- Internal aperture precisely defines active area for applications with FOV and/or spot size requirements

Benefits

- Low cost and small active area

Detector Circuit Overlay

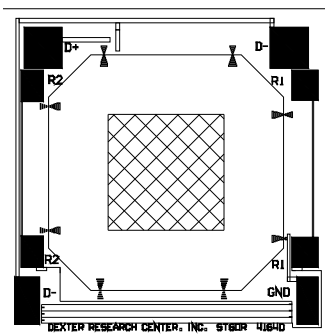

Applications

- Gas analysis
- Fire suppression
- Non-contact temperature sensors
- Horizon sensors
- Capnography

1. Specifications

Specifications apply at 23°C with KBr Window and Nitrogen encapsulating gas.

Symbol	Parameter	Min	Typ.	Max.	Unit	Comments ^[1]
AA	Active Area size	0.61 × 0.61			mm	Hot junction size, per element.
A	Element Area	.37			mm ²	
	Number of Junctions	80				Per element.
	Number of Channels	1				Per detector package.
V _s	Output Voltage	80	110	130	μV	DC, H = 330μW/cm ² [2]
SNR	Signal-to-Noise Ratio	2,365	3,513	4,792	√Hz	DC, SNR = V _s /V _n
R	Responsivity	65.2	89.7	105.9	V/W	DC, R = V _s /HA [3]
R	Resistance	45	60	70	kΩ	Detector element.
	Temperature Coefficient of R		-0.04		%/°C	Best linear fit, 0° to 85°C [4]
	Temperature Coefficient of R		0.11		%/°C	Best fit, 0° to 85°C [4]
V _n	Noise Voltage				nV/√Hz	V _n ² = 4kTR
NEP	Noise Equivalent Power				nW/√Hz	DC, NEP = V _n HA/V _s [3]
D*	Detectivity				10 ⁸ cm√Hz/Ω	DC, D* = V _s /V _n H√A [3]
T	Time Constant		18		ms	Chopped, -3dB point [4]
FOV	Field of View	72°/90°			Degrees	For FOV description, see Package Outline Drawings .
	Package Type	TO-5				Standard package hole size: 0.060" × 0.060"
T _a	Operating Temperature	-50		+125	°C	
	CO ₂ Filter, Central Wave Length		4.260		μm	

1. General specifications: Flat spectral response from 100nm to > 100μm. Linear signal output from 10⁻⁶ to 0.1W/cm². Maximum incident radiance 0.1W/cm², damage threshold ≥ .5W/cm².
2. Test conditions: 500K Blackbody source; Detector active surface 10cm from 0.6513cm diameter Blackbody Aperture.
3. A is detector area in mm².
4. Parameter is not 100% tested. 90% of all units meet these specifications.

2. Package Outline Drawings

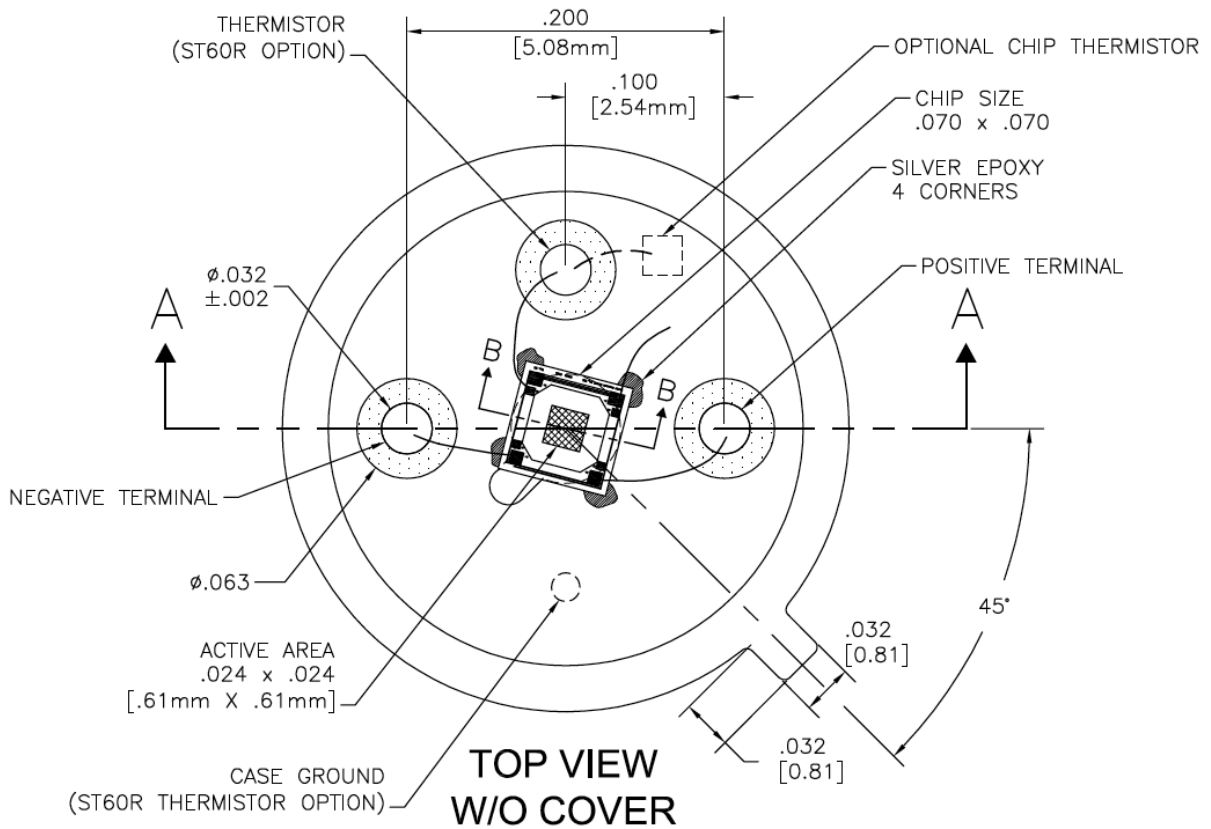

Figure 1. Package Outline Drawings – Top View

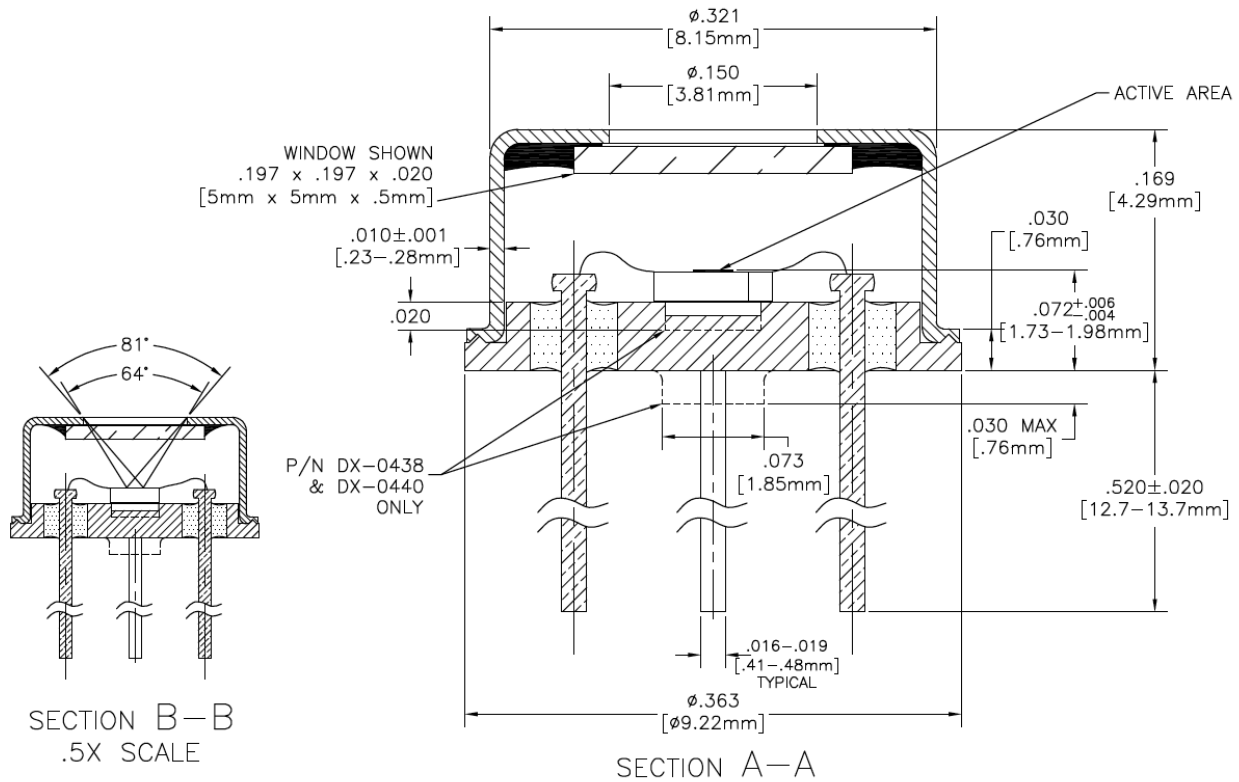

Figure 2. Package Outline Drawings – Side View

3. Ordering Information

Orderable Part Number	Package	Temperature	Carrier Type
RH5Z0610D20GZO#ADO	9.22mm TO-5 package	-50 to +125°C	Tray

4. Revision History

Revision	Date	Description
1.00	Aug 31, 2021	Initial release.