

SILICON RECTIFIER

VOLTAGE RANGE 50 to 1000 Volts CURRENT 2.5 Amperes

FEATURES

- * Low cost
- * Low leakage
- * Low forward voltage drop
- * High current capability

MECHANICAL DATA

- * Case: Molded plastic
- * Epoxy: Device has UL flammability classification 94V-O
- * Lead: MIL-STD-202E method 208C guaranteed
- * Mounting position: Any
- * Weight: 0.54 gram

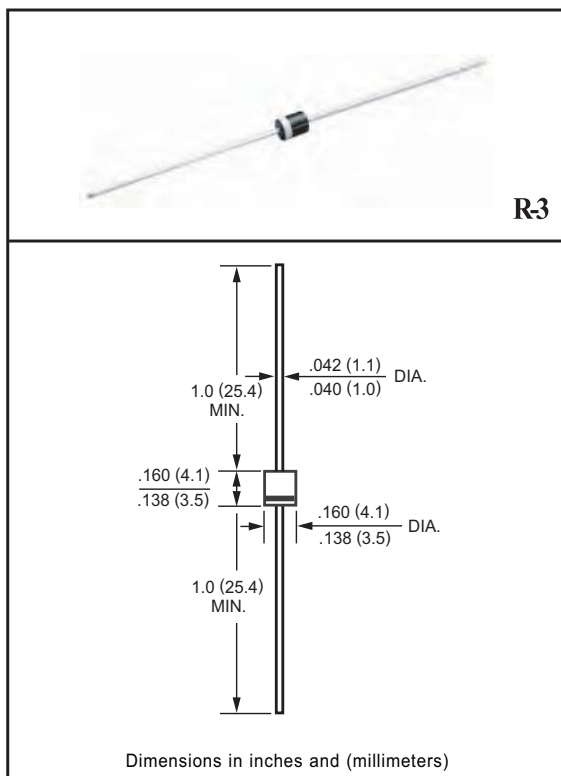

MAXIMUM RATINGS AND ELECTRICAL CHARACTERISTICS

Ratings at 25 °C ambient temperature unless otherwise specified.
Single phase, half wave, 60 Hz, resistive or inductive load.
For capacitive load, derate current by 20%.

MAXIMUM RATINGS (At TA = 25°C unless otherwise noted)

RATINGS	SYMBOL	RL251	RL252	RL253	RL254	RL255	RL256	RL257	UNITS
Maximum Recurrent Peak Reverse Voltage	VRRM	50	100	200	400	600	800	1000	Volts
Maximum RMS Voltage	VRMS	35	70	140	280	420	560	700	Volts
Maximum DC Blocking Voltage	VDC	50	100	200	400	600	800	1000	Volts
Maximum Average Forward Rectified Current at TA = 75°C	Io	2.5							Amps
Peak Forward Surge Current, 8.3 ms single half sine-wave superimposed on rated load (JEDEC method)	IFSM	150							Amps
Typical Current Squarad Time	I ² t	93.37							A ² /Sec
Typical Junction Capacitance (Note)	CJ	35							pF
Typical Thermal Resistance	RθJA	35							°C/W
Operating and Storage Temperature Range	TJ, TSTG	-55 to + 150							°C

ELECTRICAL CHARACTERISTICS (At TA = 25°C unless otherwise noted)

CHARACTERISTICS	SYMBOL	RL251	RL252	RL253	RL254	RL255	RL256	RL257	UNITS	
Maximum Instantaneous Forward Voltage at 2.5A DC	VF					1.0				Volts
Maximum DC Reverse Current at Rated DC Blocking Voltage	@TA = 25°C					1.0				uAmps
	@TA = 100°C					50				
Maximum Full Load Reverse Current Average, Full Cycle .375" (9.5mm) lead length at TL = 75°C	IR					30				uAmps

NOTES : Measured at 1 MHz and applied reverse voltage of 4.0 volts

2016-09
REV:A

RATING AND CHARACTERISTIC CURVES (RL251 THRU RL257)

FIG. 1 - TYPICAL FORWARD CURRENT DERATING CURVE

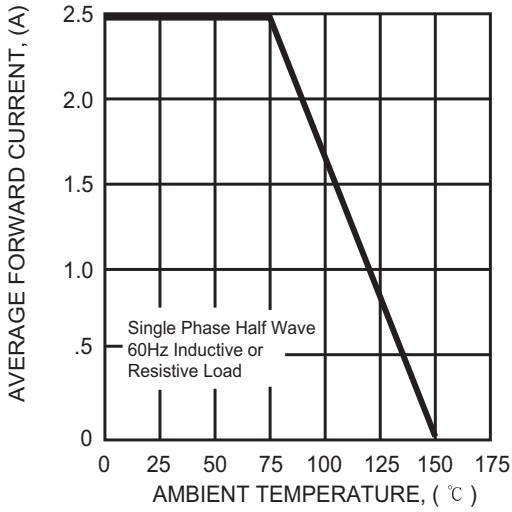

FIG. 2 - TYPICAL INSTANTANEOUS FORWARD CHARACTERISTICS

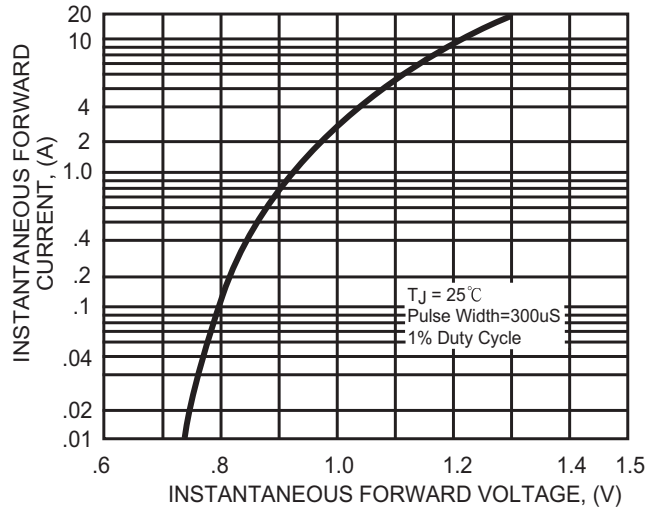

FIG. 3 - MAXIMUM NON-REPETITIVE FORWARD SURGE CURRENT

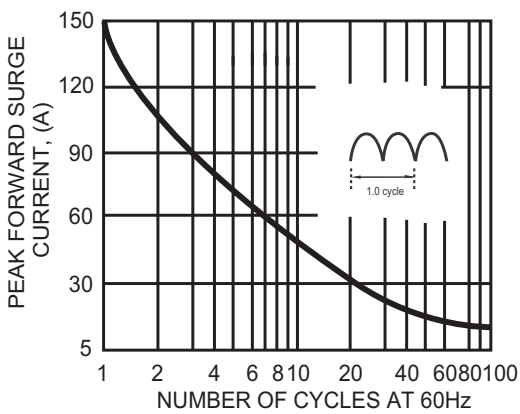

FIG. 4 - TYPICAL REVERSE CHARACTERISTICS

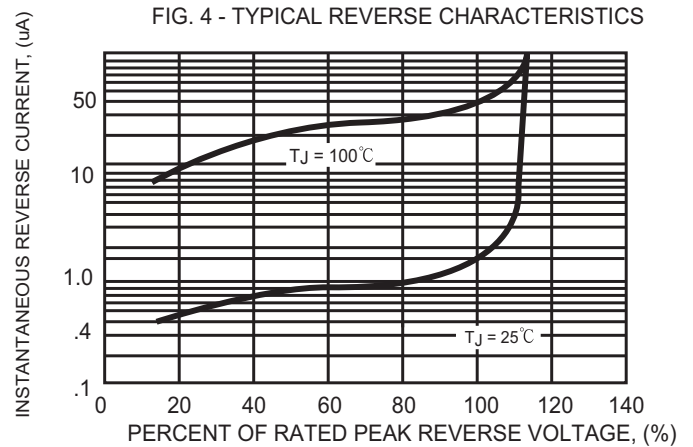
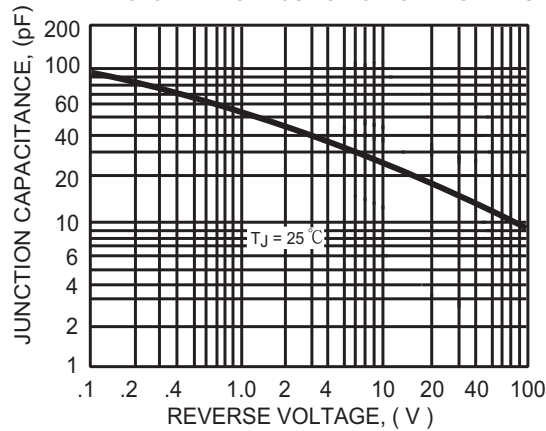

FIG. 5 - TYPICAL JUNCTION CAPACITANCE



AXIAL LEAD TAPING SPECIFICATIONS FOR RECTIFIERS

Axial lead devices are packed in accordance with EIA standard RS-296-D and specifications given below.

COMPONENT OUTLINE	COMPONENT PITCH A	INNER TAPE PITCH B		CUMULATIVE PITCH TOLERANCE
	$\pm 0.5\text{mm} (.020")$	$\pm 0.5\text{mm} (.020")$	$\pm 1.5\text{mm} (.059")$	
T-1	5.0mm	26.0mm		2.0mm/20pitch
R-1	5.0mm	26.0mm		2.0mm/20pitch
A-405	5.0mm	26.0mm		2.0mm/20pitch
A-405	5.0mm		52.4mm	2.0mm/20pitch
DO-41	5.0mm	26.0mm		2.0mm/20pitch
DO-41	5.0mm		52.4mm	2.0mm/10pitch
DO-15	5.0mm		52.4mm	2.0mm/10pitch
R-3	5.0mm		52.4mm	2.0mm/10pitch
DO-201AD	10.0mm		52.4mm	2.0mm/10pitch
R-6	10.0mm		52.4mm	2.0mm/10pitch

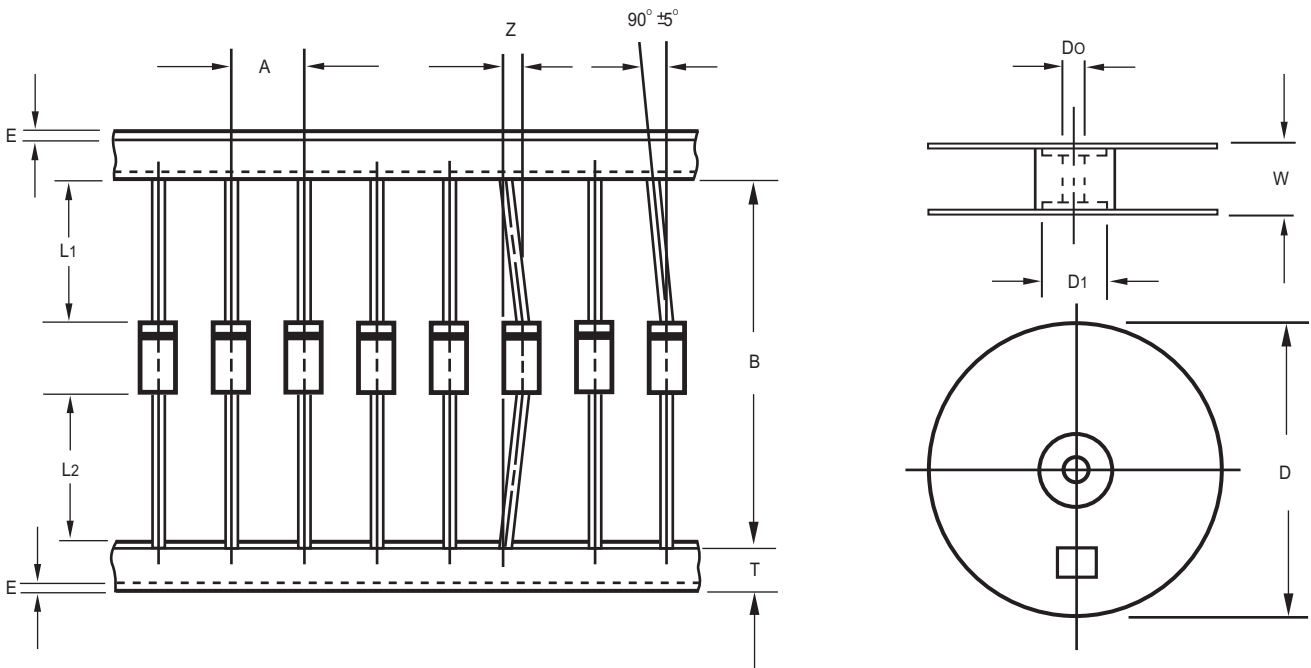

Fig.: Configuration of AXIAL LEAD TAPING

ITEM	SYMBOL	SPECIFICATIONS (mm)	SPECIFICATIONS (inch)
Component alignment	Z	1.2 Max.	0.047 Max.
Tape width	T	6.0 ± 0.4	0.236 ± 0.016
Exposed adhesive	E	0.8 Max.	0.032 Max.
Body eccentricity	$ L1-L2 $	1.0 Max.	0.039 Max.
Reel outside diameter	D	330.0	13.0
Reel inner diameter	D1	85.7 ± 0.3	3.374 ± 0.012
Feed hole diameter	Do	30.5 ± 0.4	1.201 ± 0.016
Reel width	W	79.0 ± 1.0	3.110 ± 0.039

Notes : 1. Each component lead shall be sandwiched between tapes for a minimum of 3.2mm (0.126").
2. The reel width "W" for 26mm taping is $50.0 \pm 1.0\text{mm} (1.97" \pm 0.040")$.

PACKAGING OF DIODE AND BRIDGE RECTIFIERS

REEL PACK

PACKAGE	packing code	EA PER REEL	COMPONENT SPACE(mm)	TAPE SPACE (mm)	REEL DIA (mm)	CARTON SIZE (mm)	EA PER CARTON	GROSS WEIGHT(Kg)
R-1	-T	5,000	5.0	52	330	355*360*350	20,000	7.25
A-405	-T	5,000	5.0	330	52	355*360*350	20,000	8.13
DO-41	-T	5,000	5.0	52	330	355*360*350	20,000	10.49
DO-15	-T	4,000	5.0	52	330	355*360*350	16,000	10.05
R-3	-T	3,000	5.0	52	330	355*360*350	12,000	10.37
DO-201AD	-T	1,200	9.5	52	330	355*360*350	4,800	8.93
1.5KE	-T	1,200	10.0	52.4	330	355*360*350	4,800	8.05
R-6	-T	500	9.5	52	330	355*360*350	2,000	7.29
SMA	-T	1,500	---	---	178	465*220*260	48,000	8.40
SMA	-W	5,000	---	---	330	355*360*350	80,000	14.20
MELF	-T	1,500	---	---	178	465*220*260	48,000	11.14
MELF	-W	5,000	---	---	330	355*360*350	80,000	19.60
DB-S	-T	1,000	---	---	330	355*360*350	8,000	9.85
MD	-T	500	---	---	178	465*220*260	16,000	---
MD	-W	3,000	---	---	330	355*360*350	48,000	15.50
SMB	-T	500	---	---	178	465*220*260	16,000	---
SMB	-W	3,000	---	---	330	355*360*350	48,000	13.90
SMC	-T	500	---	---	176	465*220*260	12,000	---
SMC	-W	3,000	---	---	330	355*360*350	24,000	11.50
D2PAK	-W	800	---	---	330	355*360*350	6,400	---

AMMO PACK

PACKAGE	PACKING CODE	REEL (EA)	COMPONENT SPACE(mm)	TAPE SPACE (mm)	BOX SIZE (mm)	CARTON SIZE(mm)	CARTON (EA)	GROSS WEIGHT (Kg)
R-1	-F	3,000	5.0	52	255*73*100	402*270*225	30,000	8.5
A-405	-F	3,000	5.0	52	255*73*100	402*270*225	30,000	9.6
DO-41	-F	3,000	5.0	52	255*73*100	402*270*225	30,000	13.0
DO-15	-F	1,500	5.0	52	255*73*100	402*270*225	15,000	8.8
R-3	-F	1,500	5.0	52	255*73*100	402*270*225	15,000	11.2
DO-201AD	-F	600	9.5	52	255*73*100	402*270*225	6,000	9.9
R-6	-F	300	9.5	52	255*73*100	402*270*225	3,000	8.7
R-1	-E	3,000	5.0	26	256*46*94	347*320*220	42,000	8.35
A-405	-E	3,000	5.0	26	256*46*94	347*320*220	42,000	9.61
DO-41	-E	3,000	5.0	26	256*46*94	347*320*220	42,000	12.41
R-1	-J	3,000	12.7	---	328*170*42	355*360*350	42,000	13.93
R-1	-I	2,000	12.7	---	328*170*42	355*360*350	28,000	9.31
A405	-N	2,000	12.7	---	328*170*42	355*360*350	28,000	11.41



Attachment information about RL25X

1. Internal Circuit



2. Marking on the body

