

Doodle Labs Smart Radio – RM-5800

Advanced MIMO Mesh Router in a tiny Form Factor

Smart Radio Overview



Embedded



External

The Smart Radio is an advanced 2x2 MIMO mesh router designed for easy plug & play integration. The tiny module carries all bi-directional communication (e.g. Telemetry, Video) in a single high-speed broadband RF channel.

Due to its very low SWaP-C (Space, Weight and Power, Cost), the Smart Radio is very popular for mobile IIoT (Industrial Internet of Things) applications like drones and autonomous vehicles across various industries.

The Smart Radio employs Doodle Labs' patented Mesh Rider® technology with state-of-the-art RF and networking capabilities that enable communication further, faster, and more reliably than any comparable solution on the market. For example, the Ultra Reliable Low Latency Channel (URLLC) transports important command and control data over the wireless link, while a concurrent video-optimized streaming channel carries crystal clear 4K video.

The Smart Radio is available in many frequency bands between 100 MHz and 6 GHz in form-factor compatible models. This allows customers to switch the operating band by simply swapping radio module, avoiding costly re-design efforts when expanding to new markets that require new frequencies. The Smart Radio is available in Embedded, External and Pocketable form factors.

For more information, please visit - <https://doodlelabs.com/smart-radio/>

Samples available on Mouser: <https://www.mouser.com/search/refine.aspx?N=4248121056>

Key Features - Smart Radio Platform

PERFORMANCE RF

- Long range (field tested >100km) and high throughput (up to 100 Mbps)
- Interference resistant COFDM for robust link quality in difficult RF environments
- Exceptional Multipath and NrLOS MIMO performance
- Adaptive radio modulations from BPSK up to 64QAM, with continuous per packet optimization to maximize link performance in dynamic environments
- Software defined channel size for efficient re-use of spectrum
- Convolutional coding, Forward Error Correction (FEC), ACK-retransmits, Maximal Ratio Combining, Spatial Multiplexing, and Space Time Block Coding for robust data transmission over noisy spectrum
- Single channel, Time Division Duplexing (TDD) for bi-directional traffic
- Resistant to high-power jamming signals
- ATPC for widely dispersed mesh network
- Built-in Spectrum Scanner to help mitigate interference issues

PERFORMANCE NETWORKING

- Ultra-Reliable Low Latency Channel (URLLC) for Command and Control
- Optimized video streaming channel for Unicast and Multicast transport
- Self-healing/self-forming multi-frequency mobile mesh for highly reliable network with redundancy
- AES 256 and 128 bit encryption; FIPS-2, Level 2 compliant
- End-to-end IP architecture with Ad Hoc, WDS transparent bridge, Client, AP, and Internet Gateway operating modes
- Embedded network management APIs

ADDITIONAL FEATURES

- Very small size, weight, and power (SWaP-C) for mobile applications
- Ethernet, USB, and UART interfaces to allow easy integration into different system architectures
- Leverage the benefits of the most extensible OpenWrt ecosystem and install 3rd party IoT applications
- Rugged, vibration resistant construction to meet MIL-specs
- MIL-spec temp range (-40C to +85C)
- High quality, manufactured in ISO 9001 and ISO 14001 certified facilities
- COTS – Commercial off the Shelf
- Extended lifespan and availability

Band Introduction – 5725~5875 MHz ISM Band

The 5.8 GHz ISM Band ranges from 5725~5875 MHz. Due to its globally unlicensed nature, the 5.8 GHz ISM band is popular for establishing wireless data links for Industrial IoT use cases. The major functions of systems operating in this band are point-to-point communications, video surveillance, control of robotic systems and unmanned aerial vehicles data links supporting exchange of sensor data.

System Integration

The Smart Radio has been designed to be nearly plug and play. Only Ethernet/USB, power supply, and antenna connections are required for integration.

Visit [Doodle Labs Technical Library](#) for extensive design-in documents.

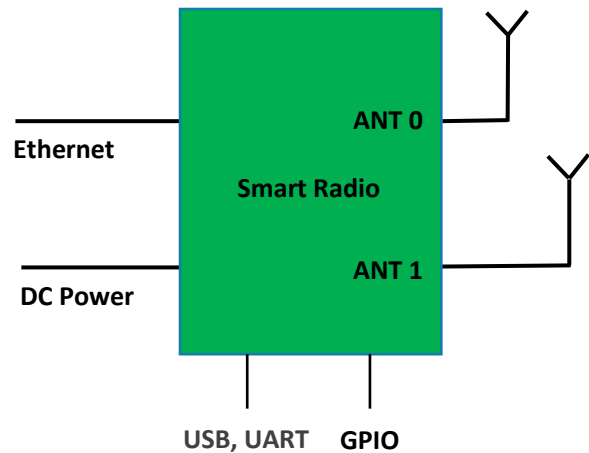

Fresnel Zone Clearance



RF Line of Sight (LOS) is defined by Fresnel Zones which are ellipse shaped areas between any two radios. The radius of the *Fresnel Zone* at its widest point is shown in the figure.

The primary Fresnel zone is required to be at least 60% clear of any obstruction to ensure the highest performance of wireless link.

Link Distance

Smart Radio's Mesh Rider waveform has been field tested for >100km. The link distance depends on many factors, mainly Antenna gain, Line of Sight obstructions, Fresnel Zone clearance and environmental noise conditions. The charts below give an indication of radio's performance in a typical configuration. Refer to the App Note – [Optimizing the Link Distance](#) for more details.

**Remote Antenna = 6 dBi, Control Station Antenna = 12 dBi,
Fade Margin = 10 dBm, Fresnel Zone 60% Clearance**

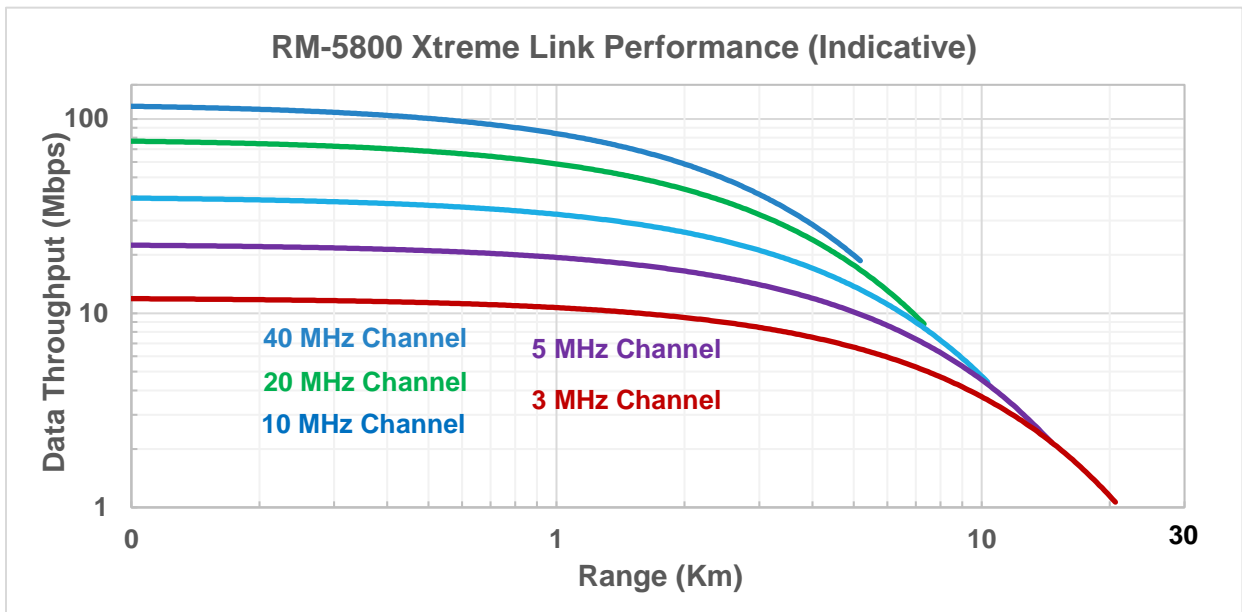

Technical Specifications (RM-5800)

Model Category	Xtreme
ORDERING CODES	
Radio Configuration	2x2 MIMO
Model # (Embedded) (v3 hardware)	RM-5800-2J-XM (Industrial temp) RM-5800-2J-XMC (Commercial temp)
Model # (External) (v3 hardware)	RM-5800-2J-XE (Industrial temp) RM-5800-2J-XEC (Commercial temp)
Model Options	Integrated GPS - add G suffix PoE (External only) - add O suffix
Evaluation Kit	EK-5800-2J (Breakout board for Embedded model)
Design-In Documentation	https://www.doodlelabs.com/technologies/technical-library/
PERFORMANCE OVERVIEW	
Wireless Protocol	TDD with Carrier Sense Multiple Access with Collision Avoidance (Not compatible with IEEE802.11 (WiFi))
Max Operating Range	>20 Km (Recommended), (Max field demonstrated range >100km)
Max Data Throughput at 10-meter range (Indicative)	100 Mbps (40 MHz Channel) 80 Mbps (20 MHz Channel) 40 Mbps (10 MHz Channel) 20 Mbps (5 MHz Channel) 12 Mbps (3 MHz Channel)
Over the Air Data Encryption	256-bit AES (12 Mbps max throughput) (FIPS140-2, Level 2 compliant)
Operating Modes	Mesh, Relay, Routed Client, AP, Transparent Bridge, Internet Gateway
Command & Control channel	Ultra-Reliable Low Latency Channel (URLLC). Latency 3-30 ms
Video Channel	Optimized video streaming with Unicast and Multicast transmission
Spectrum Scan	Automatic spectrum scan on boot up.
Mesh Automatic Transmit Power Control (M-ATPC)	Intelligently adjusts the transmit output power based on signal strength. Allows the Smart Radios to be utilized in a widely dispersed and dynamic mesh.

Model Category	Xtreme
RF SPECIFICATIONS	
Frequency Range	5725-5875 MHz
Channel Sizes (Software Selectable)	3, 5, 10, 20, 40 MHz
Radio Data Rate (Modulation Coding Scheme – MCS)	Dynamic Link Auto Adaptation
RF Power Output (Typ) Each radio individually calibrated	800mW (29 dBm), @ MCS 0,8 400mW (26 dBm), @ MCS 3,11 250mW (24 dBm), @ MCS 5,13 0.200W (23 dBm), @ MCS 7,15
Antenna Signal Strength	-25 to -85 dBm (Recommended), Absolute Maximum= +12 dBm
Receiver LNA Gain	>10 dB
RF Power Control	30-33 dBm
Integrated Antenna Port Protection	Able to withstand open port; >10 KV (contact) and >15KV (open air discharge) as per IEC-61000-4-2
Wireless Error Correction	FEC, ARQ
Frequency Accuracy	±10 ppm max over life
Control for External Power Amp	DC biased signal over RF port
Automatic Transmit Power Control (ATPC)	Automatic adjustment of Tx power based on signal level, which ensures optimal link health at both short and long distances
NETWORKING SPECIFICATIONS	
Mesh Router	Self-Forming/Self-Healing, Peer to Peer
Video Multicast	High Rate
Custom Software Package Manager	OPKG
Device Management	SSH, RPC-JSON, UCI, GUI
Access control	Password, MAC #, IP #, Port filtering

Model Category	Xtreme
Network Security	VPN, L2TP, GRE, STP
Supported Protocols	IPv6, QoS, DNS, HTTPS, IP, ICMP, NTP, DHCP
Integrate with 3rd Party Apps	Integrate with various apps e.g. ATAK, QGroundControl, and more
Software Upgrade	Over the air software upgrade supported
HARDWARE SPECIFICATIONS	
Case Material	N/A (OEM) Aluminum (Embedded & External)
Operating Voltage	5.5~42V DC Passive PoE for External form factor
Dimensions	65 x 57 x 12 mm, 62 grams (Embedded)
	148 x 137 x 58 mm, 540 grams (External)
Antenna Connection	2x MMCX-Female (Embedded) 2x SMA-Female (External)
Host Interface (Embedded)	2x Ethernet (100 Base-T), 1x UART (3.3V FT234XD chipset), 2x USB 2.0 Hub ports and 3x GPIO
Host Interface (External)	2x Ethernet (100 Base-T), 1x RS232, 2x USB 2.0 Hub ports and 3x GPIO
Temperature Range (Operating)	Industrial: -40°C to +85°C, Commercial: -10°C to +65°C
	System's thermal design should ensure that the radio's case temperature is maintained within these specifications.
Ingress Protection (Embedded)	IP 50 (Embedded), Dust Protected, No Liquids
Ingress Protection (External)	IP66 — Protected from high pressure water jets from any direction.
Shock and Vibration Resistance	Compliant to MIL-STD-810H for high shock and vibration
DC Power Consumption	<ul style="list-style-type: none"> 14.5W @ 30dBm RF power in UDP data Tx mode 9.8W @ 200mW (23 dBm) RF power in UDP data Tx mode 5.6W in data Rx mode 1.2W in Sleep mode

Model Category	Xtreme
Reliability	Extreme Reliability, IPC Class 2 standard with Class 3 options
Integrated GPS (Optional)	Simultaneous multiple constellations (GPS/Galileo/Glonass/BeiDou/QZSS), 1.5 meter CEP position accuracy, -163 dBm tracking sensitivity
Integrated CPU	MIPS 24K, 540 MHz, 32MB Flash, 64MB DDR2 RAM
MTBF	>235k hours (25 years)
Temper Evident Seal	Yes
Humidity (Operating)	0% – 95% (Non-condensing)
Life Cycle Planning	Extended lifespan with up to 7 years guaranteed delivery
REGULATORY INFORMATION	
J/F-12 Certification	11929 (NTIA DD1494 available upon request)
FCC ID	2AG87RM-5800
Industry Canada (IC)	21411-RM5800
Flammability Rating	UL94 V-0 compliant
Regulatory Requirements	Designed and verified to meet various regulatory requirements. Formal testing and approval are required for the Integrator's antenna type. The Integrator is responsible for obtaining all regulatory approvals in target markets for the finished product.
RoHS/WEEE Compliance	Yes. 100% Recyclable/Biodegradable packaging
ADDITIONAL RF SPECIFICATIONS	
Radio Data Rates (Dynamic Link Auto Adaptation)	MCS15 = 64QAM (5/6), 2x2 MIMO MCS14 = 64 QAM (3/4), 2x2 MIMO MCS13 = 64 QAM (2/3), 2x2 MIMO MCS12 = 16QAM (3/4), 2x2 MIMO MCS11 = 16QAM (1/2), 2x2 MIMO MCS10 = QPSK (3/4), 2x2 MIMO MCS9 = QPSK (1/2), 2x2 MIMO

Model Category	Xtreme
	<p>MCS8 = BPSK (1/2), 2x2 MIMO</p> <p>MCS7 = 64QAM (5/6)</p> <p>MCS6 = 64 QAM (3/4)</p> <p>MCS5 = 64 QAM (2/3)</p> <p>MCS4 = 16QAM (3/4)</p> <p>MCS3 = 16QAM (1/2)</p> <p>MCS2 = QPSK (3/4)</p> <p>MCS1 = QPSK (1/2)</p> <p>MCS0 = BPSK (1/2)</p>
<p>Rx Sensitivity (3 MHz Channel BW)</p>	<p>-100 dBm @ MCS 0</p> <p>-97 dBm @ MCS 1</p> <p>-95 dBm @ MCS 2</p> <p>-92 dBm @ MCS 3</p> <p>-87 dBm @ MCS 4</p> <p>-85 dBm @ MCS 5</p> <p>-82 dBm @ MCS 6</p> <p>-79 dBm @ MCS 7</p> <p>-97 dBm @ MCS 8</p> <p>-93 dBm @ MCS 9</p> <p>-91 dBm @ MCS 10</p> <p>-88 dBm @ MCS 11</p> <p>-84 dBm @ MCS 12</p> <p>-80 dBm @ MCS 13</p> <p>-79 dBm @ MCS 14</p> <p>-78 dBm @ MCS 15</p>
<p>Rx Sensitivity (5 MHz Channel BW)</p>	<p>-98 dBm @ MCS 0</p> <p>-95 dBm @ MCS 1</p> <p>-93 dBm @ MCS 2</p> <p>-90 dBm @ MCS 3</p> <p>-85 dBm @ MCS 4</p> <p>-83 dBm @ MCS 5</p> <p>-80 dBm @ MCS 6</p> <p>-77 dBm @ MCS 7</p> <p>-95 dBm @ MCS 8</p>

Model Category	Xtreme
	-91 dBm @ MCS 9 -89 dBm @ MCS 10 -85 dBm @ MCS 11 -82 dBm @ MCS 12 -78 dBm @ MCS 13 -77 dBm @ MCS 14 -76 dBm @ MCS 15

<p>Rx Sensitivity (10 MHz Channel BW)</p>	<p>-96 dBm @ MCS 0 -93 dBm @ MCS 1 -91 dBm @ MCS 2 -88 dBm @ MCS 3 -83 dBm @ MCS 4 -81 dBm @ MCS 5 -78 dBm @ MCS 6 -75 dBm @ MCS 7 -93 dBm @ MCS 8 -89 dBm @ MCS 9 -87 dBm @ MCS 10 -84 dBm @ MCS 11 -80 dBm @ MCS 12 -76 dBm @ MCS 13 -75 dBm @ MCS 14 -74 dBm @ MCS 15</p>
<p>Rx Sensitivity (20 MHz Channel BW)</p>	<p>-93 dBm @ MCS 0 -90 dBm @ MCS 1 -88 dBm @ MCS 2 -85 dBm @ MCS 3 -80 dBm @ MCS 4 -78 dBm @ MCS 5 -75 dBm @ MCS 6 -72 dBm @ MCS 7 -90 dBm @ MCS 8 -86 dBm @ MCS 9 -84 dBm @ MCS 10 -81 dBm @ MCS 11 -77 dBm @ MCS 12 -73 dBm @ MCS 13 -72 dBm @ MCS 14 -71 dBm @ MCS 15</p>