

150V N-Ch Power MOSFET

Feature

- High Speed Power Switching
- Enhanced Body diode dv/dt capability
- 100% UIS tested
- Pb-free lead plating

V_{DS}	150	V
$R_{DS(on),typ}$	6.0	m Ω
I_D	140	A

Application

- Synchronous Rectification in SMPS
- Hard Switching and High Speed Circuit
- Power Tools
- UPS
- Motor Control
- Halogen-free

TO-263

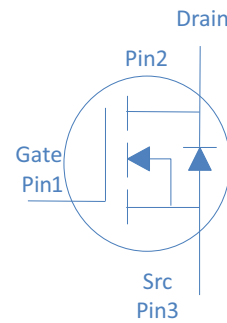
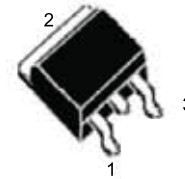

Part Number	Package	Marking
RM140N150BHD	TO-263	140N150

Absolute Maximum Ratings at $T_J = 25^\circ\text{C}$ (unless otherwise specified)

Parameter	Symbol	Conditions	Value	Unit
Continuous Drain Current	I_D	$T_C = 25^\circ\text{C}$	140	A
		$T_C = 100^\circ\text{C}$	99	
Drain to Source Voltage	V_{DS}	-	150	V
Gate to Source Voltage	V_{GS}	-	± 20	V
Pulsed Drain Current	I_{DM}	-	500	A
Avalanche Energy, Single Pulse	E_{AS}	$L = 0.4\text{mH}, T_C = 25^\circ\text{C}$	405	mJ
Power Dissipation	P_D	$T_C = 25^\circ\text{C}$	300	W
Operating and Storage Temperature	T_J, T_{stg}	-	-55 to 175	$^\circ\text{C}$

Absolute Maximum Ratings

Parameter	Symbol	Max	Unit
Thermal Resistance Junction-Case	$R_{\theta JC}$	0.5	$^\circ\text{C/W}$
Thermal Resistance Junction-Ambient	$R_{\theta JA}$	60	$^\circ\text{C/W}$

Electrical Characteristics at $T_j = 25^\circ\text{C}$ (unless otherwise specified)

Static Characteristics						
Parameter	Symbol	Conditions	Value			Unit
			min	typ	max	
Drain to Source Breakdown Voltage	$V_{(BR)DSS}$	$V_{GS}=0V, I_D=250\mu A$	150	-	-	V
Gate Threshold Voltage	$V_{GS(th)}$	$V_{GS}=V_{DS}, I_D=250\mu A$	2	3	4	V
Zero Gate Voltage Drain Current	I_{DSS}	$V_{GS}=0V, V_{DS}=150V, T_j=25^\circ\text{C}$	-	-	1	μA
		$V_{GS}=0V, V_{DS}=150V, T_j=100^\circ\text{C}$	-	-	100	
Gate to Source Leakage Current	I_{GSS}	$V_{GS}=\pm 20V, V_{DS}=0V$	-	-	± 100	nA
Drain to Source on Resistance	$R_{DS(on)}$	$V_{GS}=10V, I_D=65A$	-	6.0	7	m Ω
Transconductance	g_{fs}	$V_{DS}=5V, I_D=20A$	-	75	-	S
Gate Resistance	R_G	$V_{GS}=0V, V_{DS}$ Open, $f=1\text{MHz}$	-	2.8	-	Ω

Dynamic Characteristics						
Input Capacitance	C_{iss}	$V_{GS}=0V, V_{DS}=75V, f=1\text{MHz}$	-	5369	-	pF
Output Capacitance	C_{oss}		-	386	-	
Reverse Transfer Capacitance	C_{rss}		-	11	-	
Total Gate Charge	Q_g	$V_{DD}=75V, I_D=20A, V_{GS}=10V$	-	64	-	nC
Gate to Source Charge	Q_{gs}		-	20	-	
Gate to Drain (Miller) Charge	Q_{gd}		-	9	-	
Turn on Delay Time	$t_{d(on)}$	$V_{DD}=75V, I_D=20A, V_{GS}=10V,$ $R_G=10\Omega,$	-	23	-	ns
Rise time	t_r		-	22	-	
Turn off Delay Time	$t_{d(off)}$		-	32	-	
Fall Time	t_f		-	15	-	

Reverse Diode Characteristics						
Diode Forward Voltage	V_{SD}	$V_{GS}=0V, I_F=20A$	-	0.9	1.2	V
Reverse Recovery Time	t_{rr}	$V_R=75V, I_F=20A, di_F/dt=100A/\mu s$	-	75	-	ns
Reverse Recovery Charge	Q_{rr}		-	150	-	nC

RATING AND CHARACTERISTICS CURVES (RM140N150BHD)

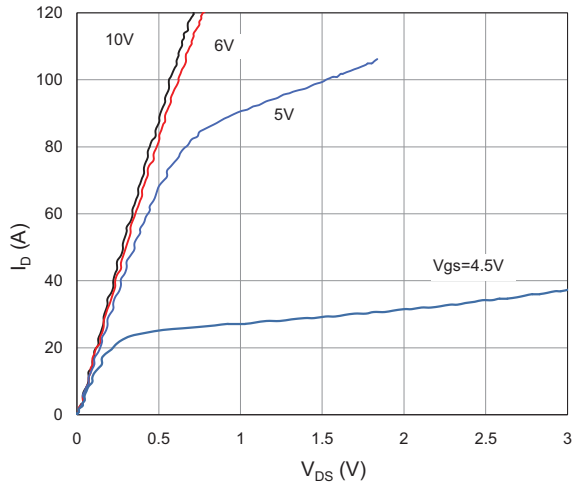

Fig 1. Typical Output Characteristics

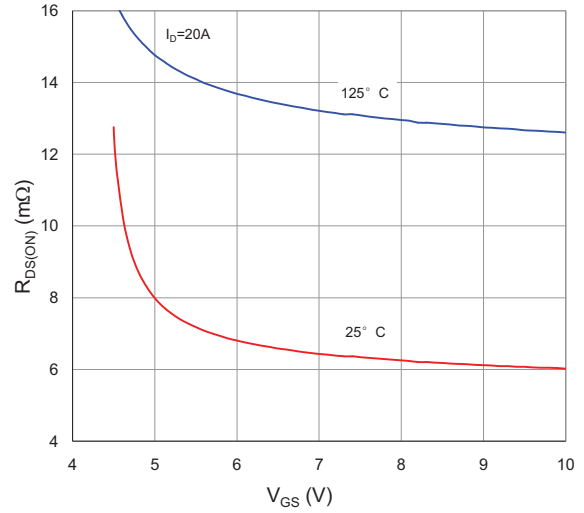

Figure 2. On-Resistance vs. Gate-Source Voltage

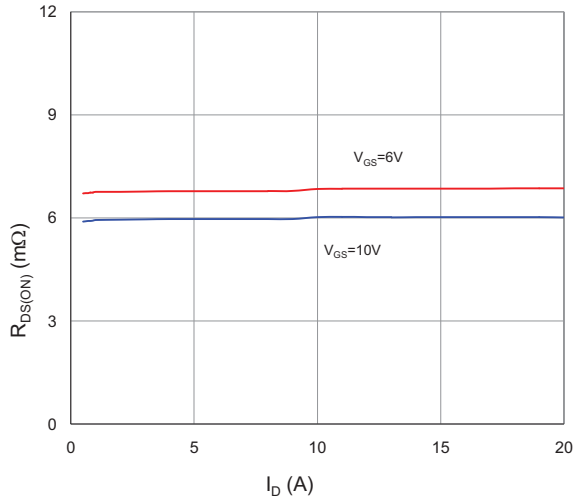

Figure 3. On-Resistance vs. Drain Current and Gate Voltage

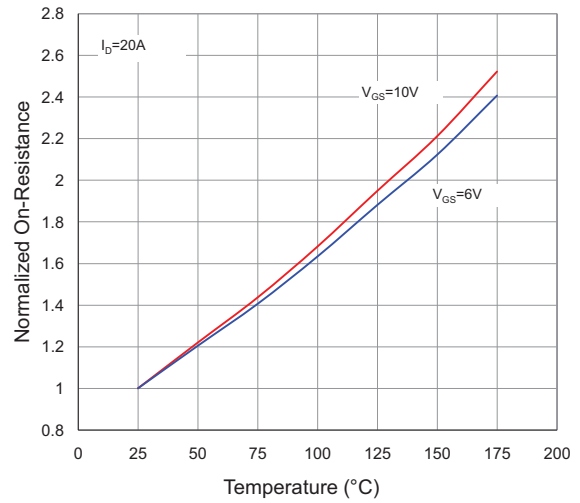

Figure 4. Normalized On-Resistance vs. Junction Temperature

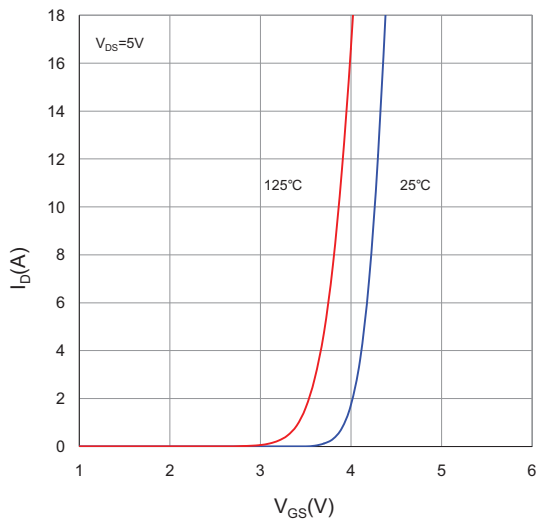

Figure 5. Typical Transfer Characteristics

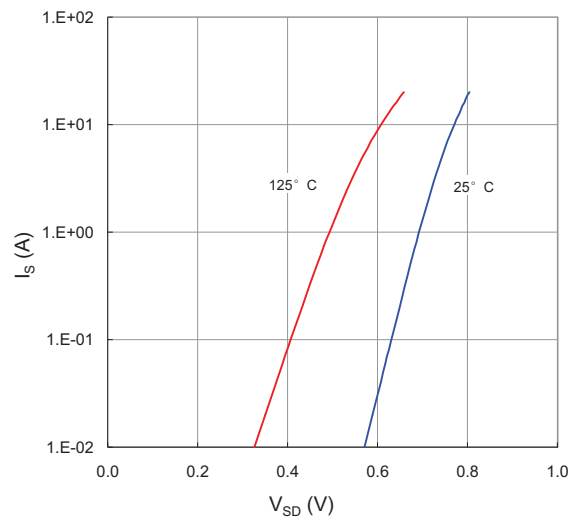

Figure 6. Typical Source-Drain Diode Forward Voltage

RATING AND CHARACTERISTICS CURVES (RM140N150BHD)

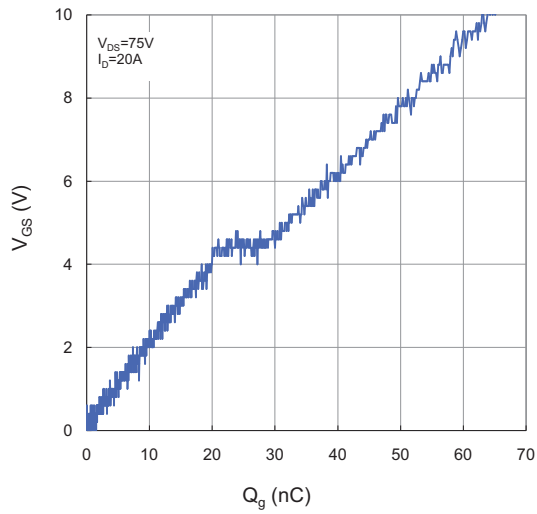

Figure 7. Typical Gate-Charge vs. Gate-to-Source Voltage

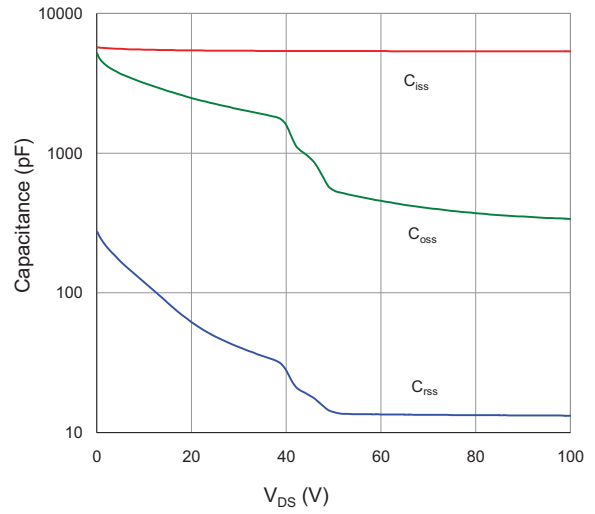

Figure 8. Typical Capacitance vs. Drain-to-Source Voltage

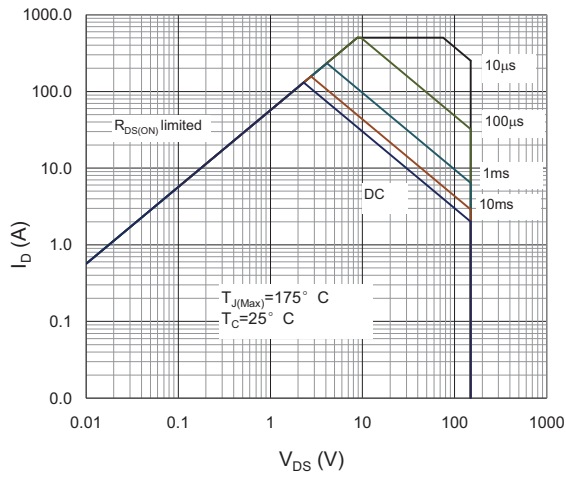

Figure 9. Maximum Safe Operating Area

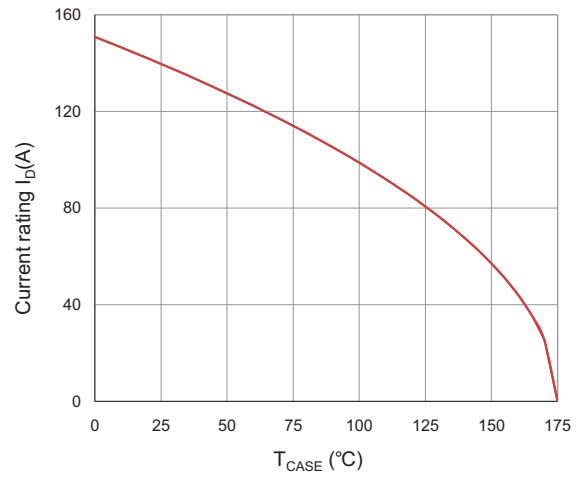

Figure 10. Maximum Drain Current vs. Case Temperature

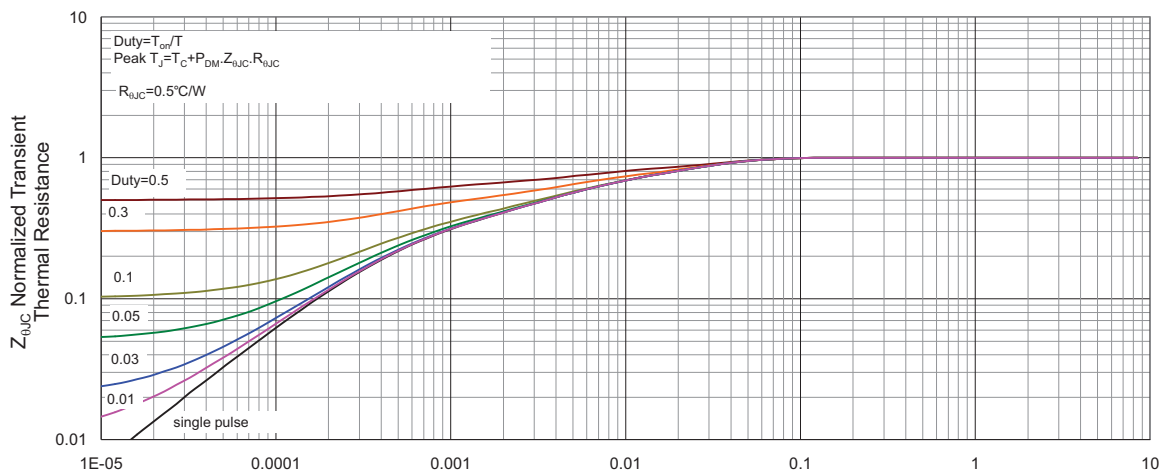
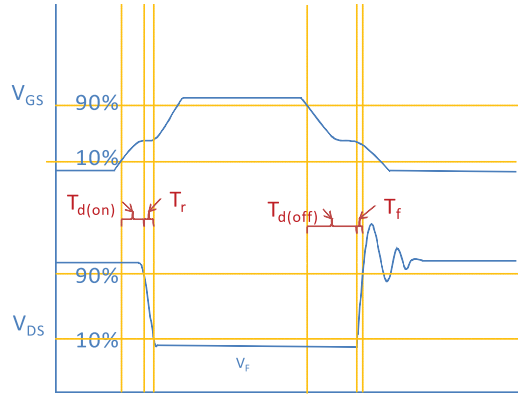
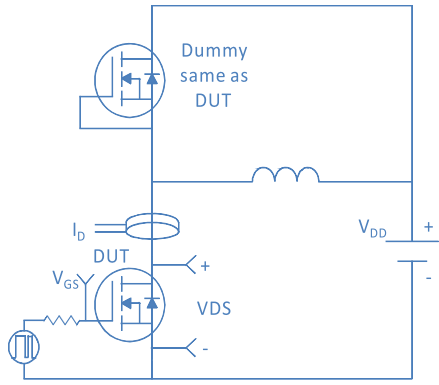
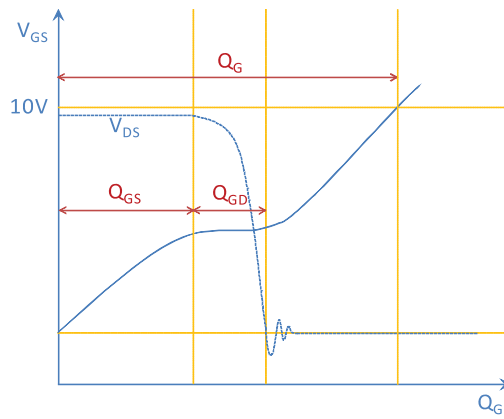
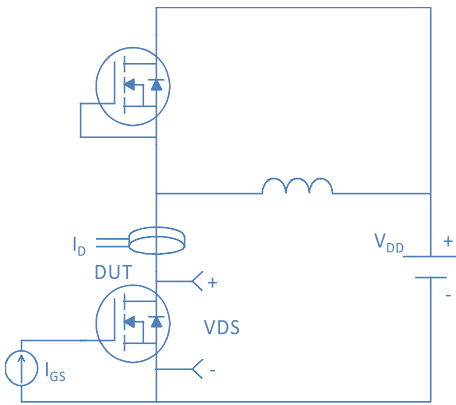

Figure 11. Normalized Maximum Transient Thermal Impedance, Junction-to-Case

Inductive switching Test



Gate Charge Test



Uclamped Inductive Switching (UIS) Test

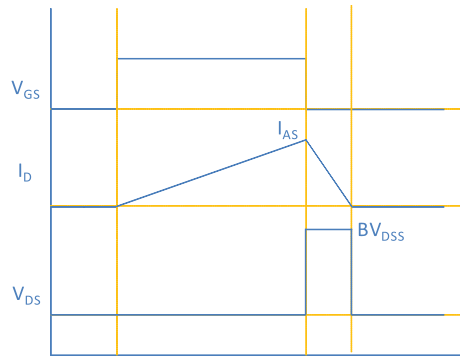
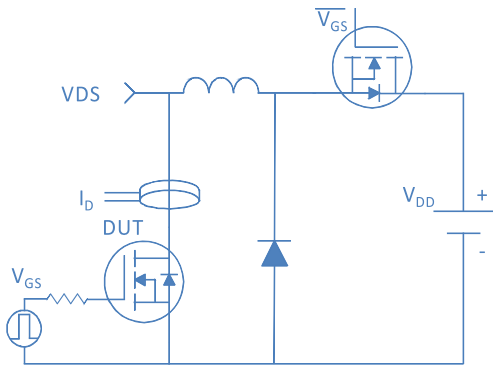

Diode Recovery Test

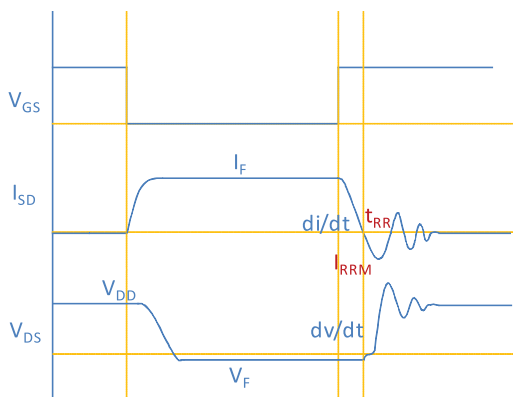
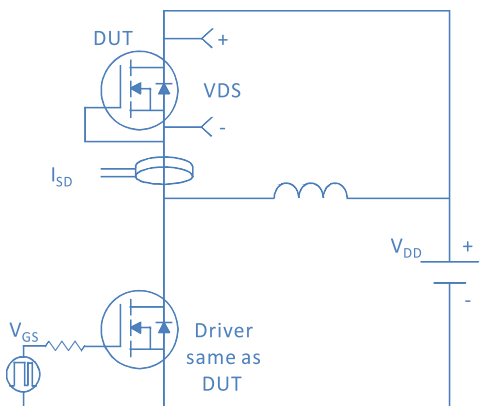

TO-263-3L Package Information

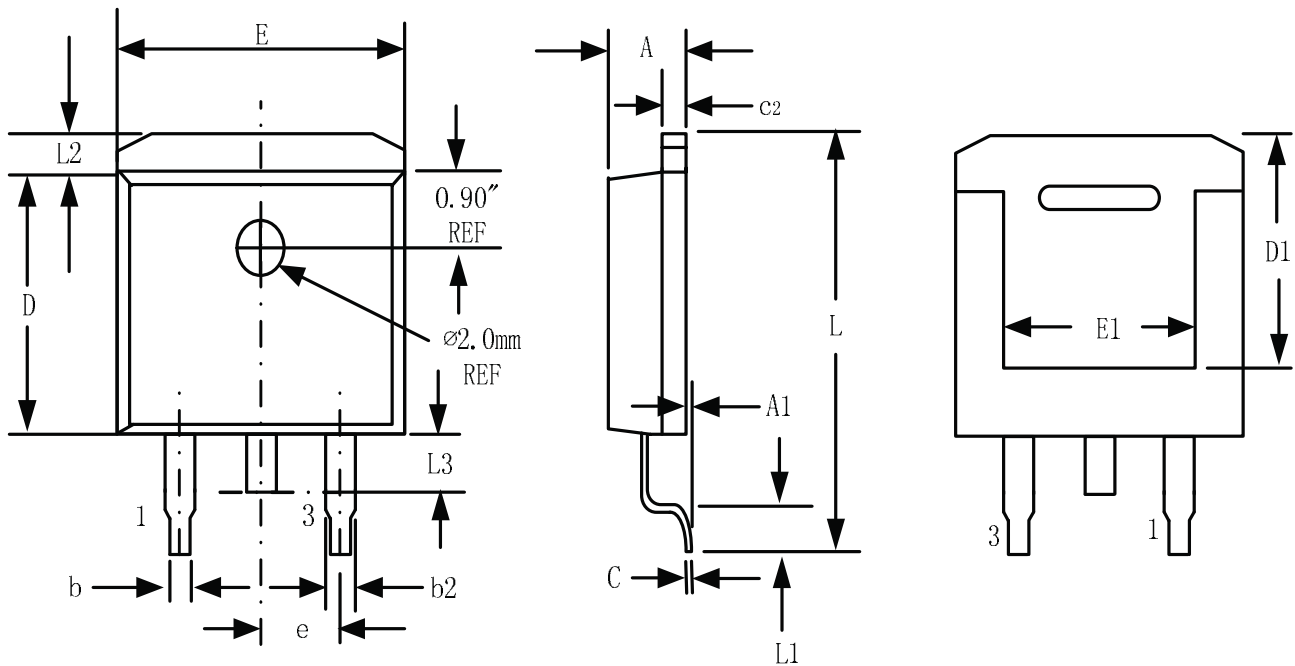

Symbol	Dimensions In Millimeters		Dimensions In Inches	
	Min.	Max.	Min.	Max.
A	4.32	4.57	0.170	0.180
A1	-	0.25		0.010
b	0.71	0.94	0.028	0.037
b2	1.15	1.40	0.045	0.055
c	0.46	0.61	0.018	0.024
c2	1.22	1.40	0.048	0.055
D	8.89	9.40	0.350	0.370
D1	8.01	8.23	0.315	0.324
E	10.04	10.28	0.395	0.405
E1	7.88	8.08	0.310	0.318
e	2.54 BSC		0.100 BSC	
L	14.73	15.75	0.580	0.620
L1	2.29	2.79	0.090	0.110
L2	1.15	1.39	0.045	0.055
L3	1.27	1.77	0.050	0.070