

N-Channel Super Junction Power MOSFET II

General Description

The series of devices use advanced super junction technology and design to provide excellent $R_{DS(ON)}$ with low gate charge. This super junction MOSFET fits the industry's AC-DC SMPS requirements for PFC, AC/DC power conversion, and industrial power applications.

Features

- New technology for high voltage device
- Low on-resistance and low conduction losses
- Small package
- Ultra Low Gate Charge cause lower driving requirements
- 100% Avalanche Tested
- ROHS compliant

Application

- Power factor correction (PFC)
- Switched mode power supplies(SMPS)
- Uninterruptible Power Supply (UPS)

$V_{DS@T_{jmax}}$	710	V
$R_{DS(ON) TYP}$	2.2	Ω
I_D	2	A

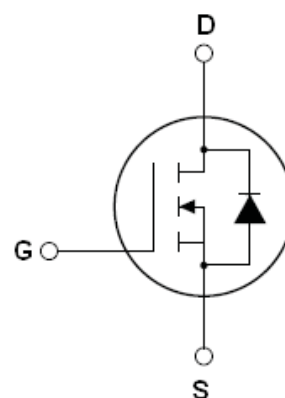

Schematic diagram

Package Marking And Ordering Information

Device	Device Package	Marking
RM2N650IP	TO-251	2N650
RM2N650LD	TO-252	2N650

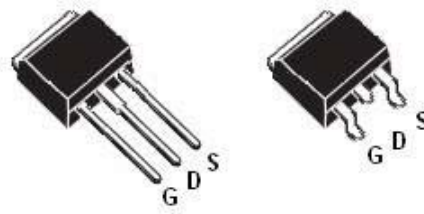

TO-251

TO-252

Table 1. Absolute Maximum Ratings ($T_c=25^\circ\text{C}$)

Parameter	Symbol	Value	Unit
Drain-Source Voltage ($V_{GS} = 0V$)	V_{DS}	650	V
Gate-Source Voltage ($V_{DS} = 0V$)	V_{GS}	± 30	V
Continuous Drain Current at $T_c=25^\circ\text{C}$	$I_{D(DC)}$	2	A
Continuous Drain Current at $T_c=100^\circ\text{C}$	$I_{D(DC)}$	1.3	A
Pulsed drain current (Note 1)	$I_{DM(pluse)}$	6	A
Maximum Power Dissipation($T_c=25^\circ\text{C}$)	P_D	23	W
Derate above 25°C		0.184	W/ $^\circ\text{C}$
Single pulse avalanche energy (Note2)	E_{AS}	45	mJ
Avalanche current (Note 1)	I_{AR}	1	A
Repetitive Avalanche energy , t_{AR} limited by T_{jmax} (Note 1)	E_{AR}	0.06	mJ

Parameter	Symbol	Value	Unit
Drain Source voltage slope, $V_{DS} \leq 480 V$,	dv/dt	50	V/ns
Reverse diode dv/dt, $V_{DS} \leq 480 V, I_{SD} < I_D$	dv/dt	15	V/ns
Operating Junction and Storage Temperature Range	T_J, T_{STG}	-55...+150	°C

Table 2. Thermal Characteristic

Parameter	Symbol	Value	Unit
Thermal Resistance, Junction-to-Case (Maximum)	R_{thJC}	5.4	°C/W
Thermal Resistance, Junction-to-Ambient (Maximum)	R_{thJA}	75	°C/W

Table 3. Electrical Characteristics (TA=25°C unless otherwise noted)

Parameter	Symbol	Condition	Min	Typ	Max	Unit
On/off states						
Drain-Source Breakdown Voltage	BV_{DSS}	$V_{GS}=0V, I_D=250\mu A$	650			V
Zero Gate Voltage Drain Current($T_C=25^\circ C$)	I_{DSS}	$V_{DS}=650V, V_{GS}=0V$			1	μA
Zero Gate Voltage Drain Current($T_C=125^\circ C$)	I_{DSS}	$V_{DS}=650V, V_{GS}=0V$			10	μA
Gate-Body Leakage Current	I_{GSS}	$V_{GS}=\pm 30V, V_{DS}=0V$			± 100	nA
Gate Threshold Voltage	$V_{GS(th)}$	$V_{DS}=V_{GS}, I_D=250\mu A$	2.5	3	3.5	V
Drain-Source On-State Resistance	$R_{DS(on)}$	$V_{GS}=10V, I_D=1A$		2200	2500	m Ω
Dynamic Characteristics						
Forward Transconductance	g_{FS}	$V_{DS} = 20V, I_D = 1A$		2		S
Input Capacitance	C_{iss}	$V_{DS}=50V, V_{GS}=0V,$ $F=1.0MHz$		190		PF
Output Capacitance	C_{oss}			13		PF
Reverse Transfer Capacitance	C_{rss}			1.1		PF
Total Gate Charge	Q_g	$V_{DS}=480V, I_D=2A,$ $V_{GS}=10V$		3.2	10	nC
Gate-Source Charge	Q_{gs}			0.6		nC
Gate-Drain Charge	Q_{gd}			1.2		nC
Intrinsic gate resistance	R_G	$f = 1 MHz$ open drain		9		Ω
Switching times						
Turn-on Delay Time	$t_{d(on)}$	$V_{DD}=380V, I_D=1A,$ $R_G=50\Omega, V_{GS}=10V$		6		nS
Turn-on Rise Time	t_r			3		nS
Turn-Off Delay Time	$t_{d(off)}$			65		nS
Turn-Off Fall Time	t_f			11		nS
Source- Drain Diode Characteristics						
Source-drain current(Body Diode)	I_{SD}	$T_C=25^\circ C$			2	A
Pulsed Source-drain current(Body Diode)	I_{SDM}				6	A
Forward On Voltage	V_{SD}	$T_J=25^\circ C, I_{SD}=2A, V_{GS}=0V$		1	1.3	V
Reverse Recovery Time	t_{rr}	$T_J=25^\circ C, I_F=2A, di/dt=100A/\mu s$		140		nS
Reverse Recovery Charge	Q_{rr}			0.65		μC
Peak reverse recovery current	I_{rrm}			9		A

Notes: 1.Repetitive Rating: Pulse width limited by maximum junction temperature

2. $T_J=25^\circ C, V_{DD}=50V, V_G=10V, R_G=25\Omega$

RATING AND CHARACTERISTICS CURVES (RM2N650IP/RM2N650LD)

Figure1. Safe operating area

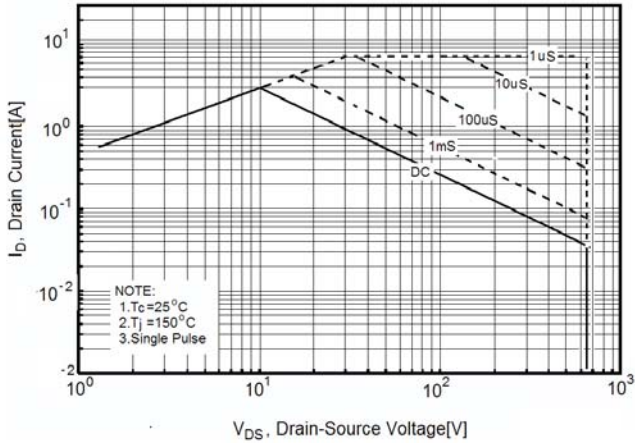

Figure2. Source-Drain Diode Forward Voltage

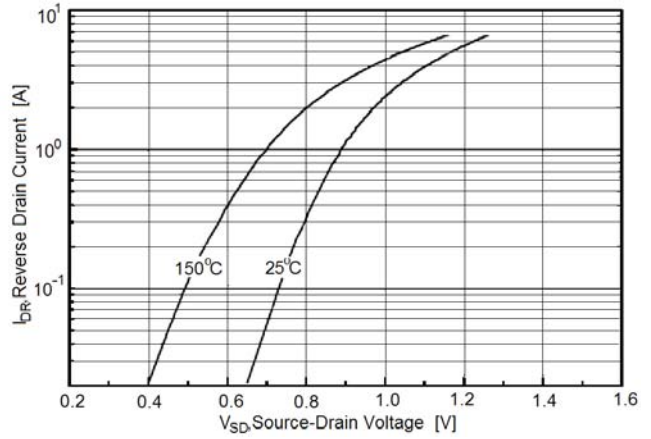

Figure3. Output characteristics

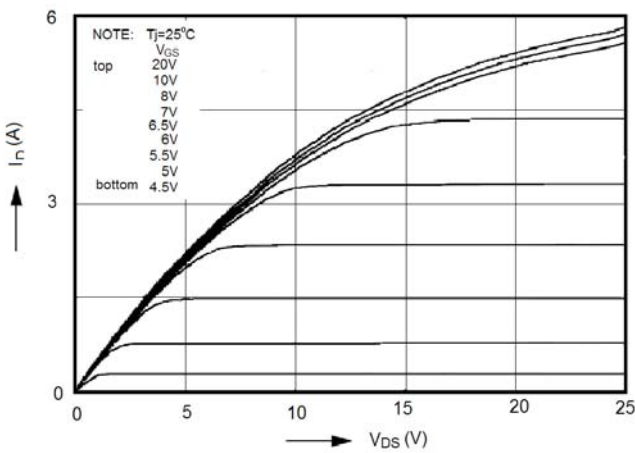

Figure4. Transfer characteristics

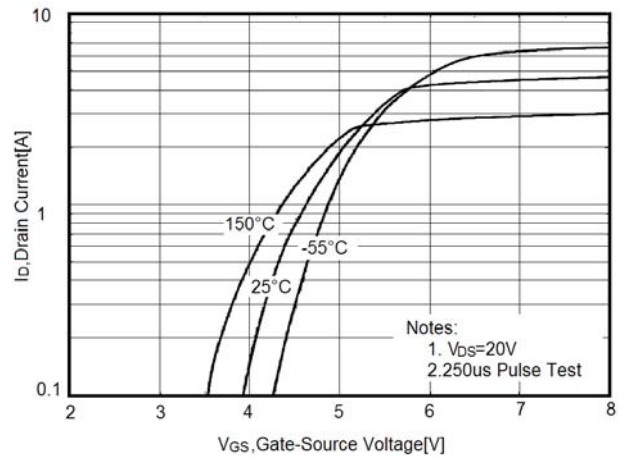

Figure5. Static drain-source on resistance

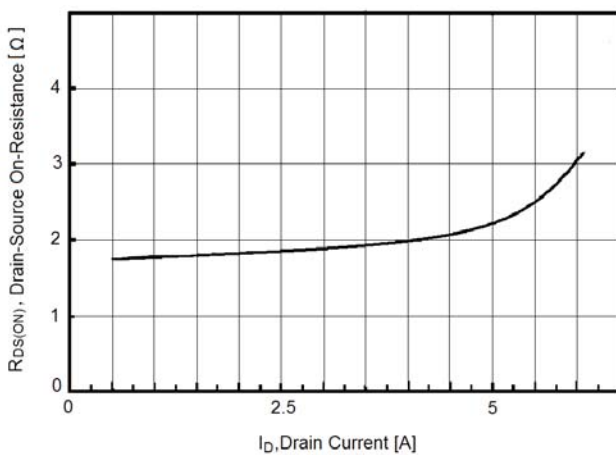
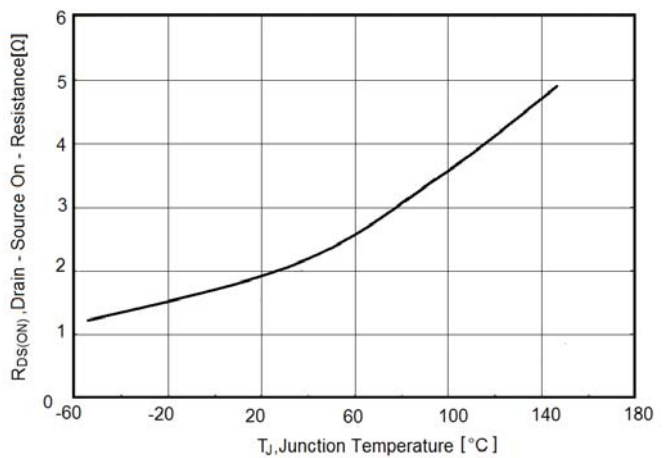

Figure6. RDS(ON) vs Junction Temperature



RATING AND CHARACTERISTICS CURVES (RM2N650IP/RM2N650LD)

Figure7. BV_{DSS} vs Junction Temperature

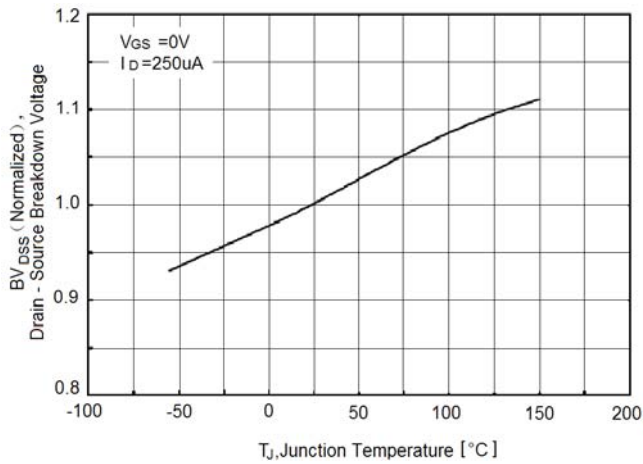

Figure8. Maximum I_D vs Junction Temperature

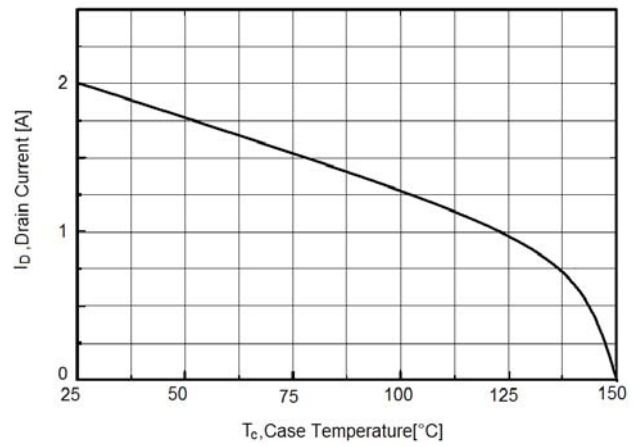

Figure9. Gate charge waveforms

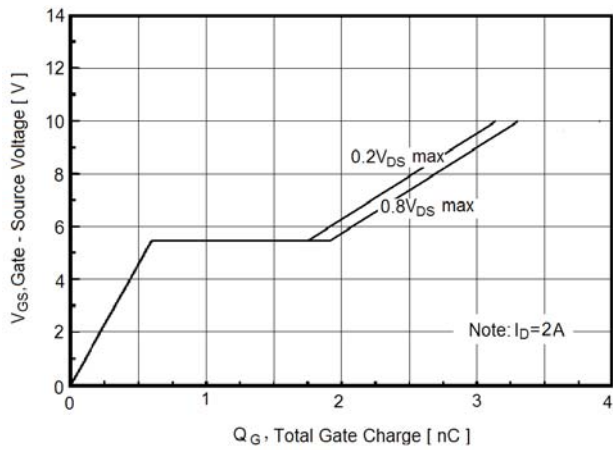

Figure10. Capacitance

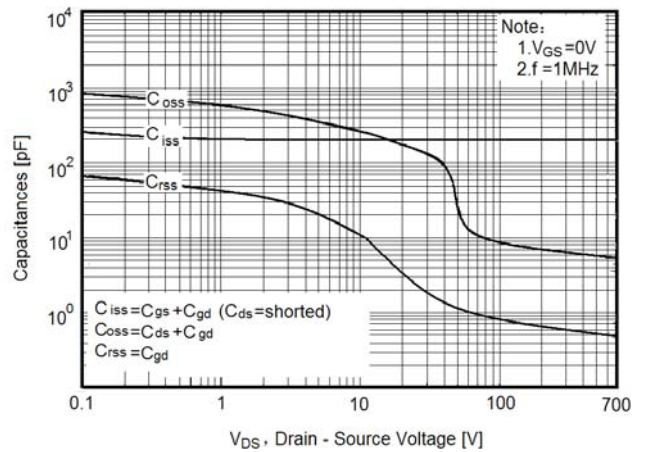
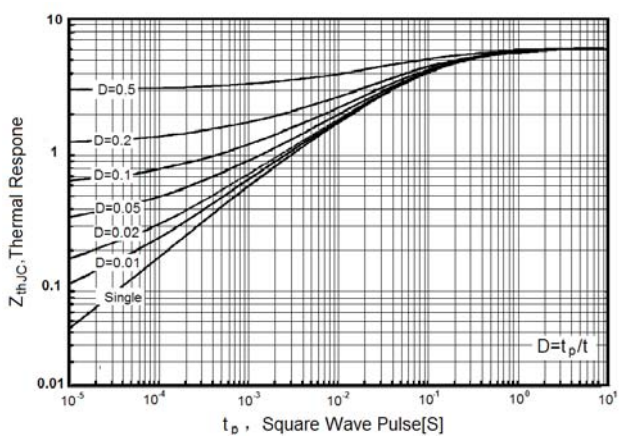
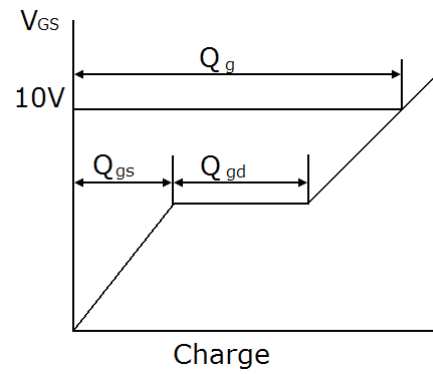
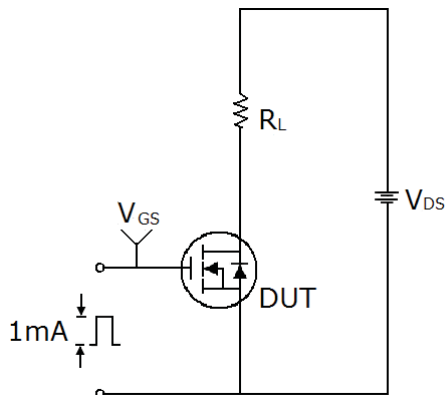

Figure11. Transient Thermal Impedance



Test circuit

1) Gate charge test circuit & Waveform



2) Switch Time Test Circuit:

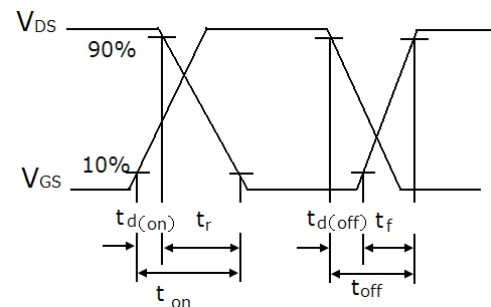
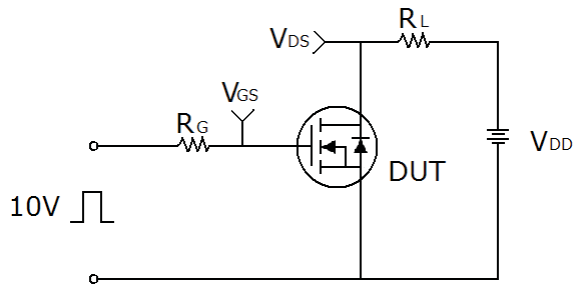

3) Unclamped Inductive Switching Test Circuit & Waveforms

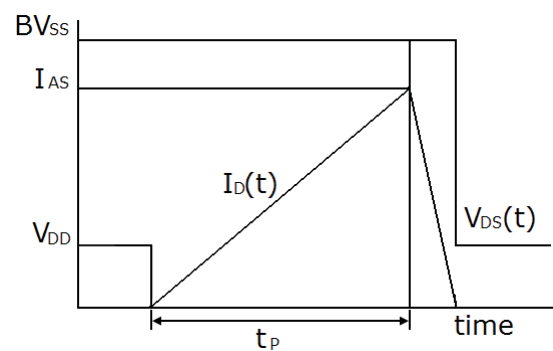
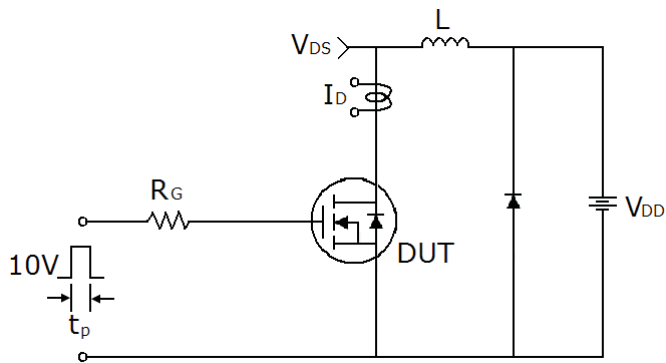



RECTRON

Marking on the body



← Rectron Logo

2 N 6 5 0 ← Part No.

16 XX

Year – Code
(Y:16-----2016
17-----2017.....)

Week – code
(WW:01~52)

TO-251 Package Information

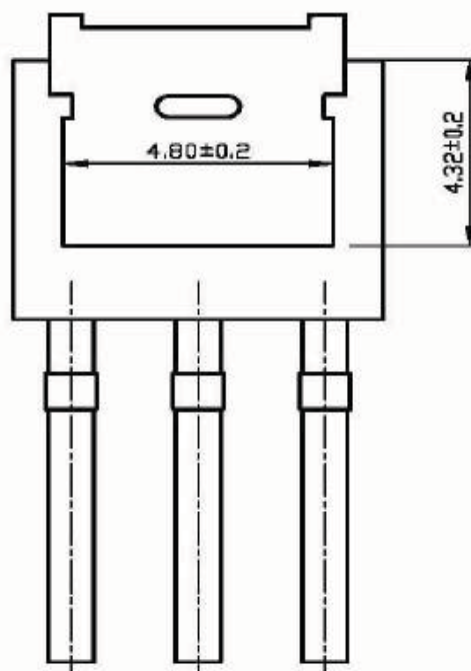
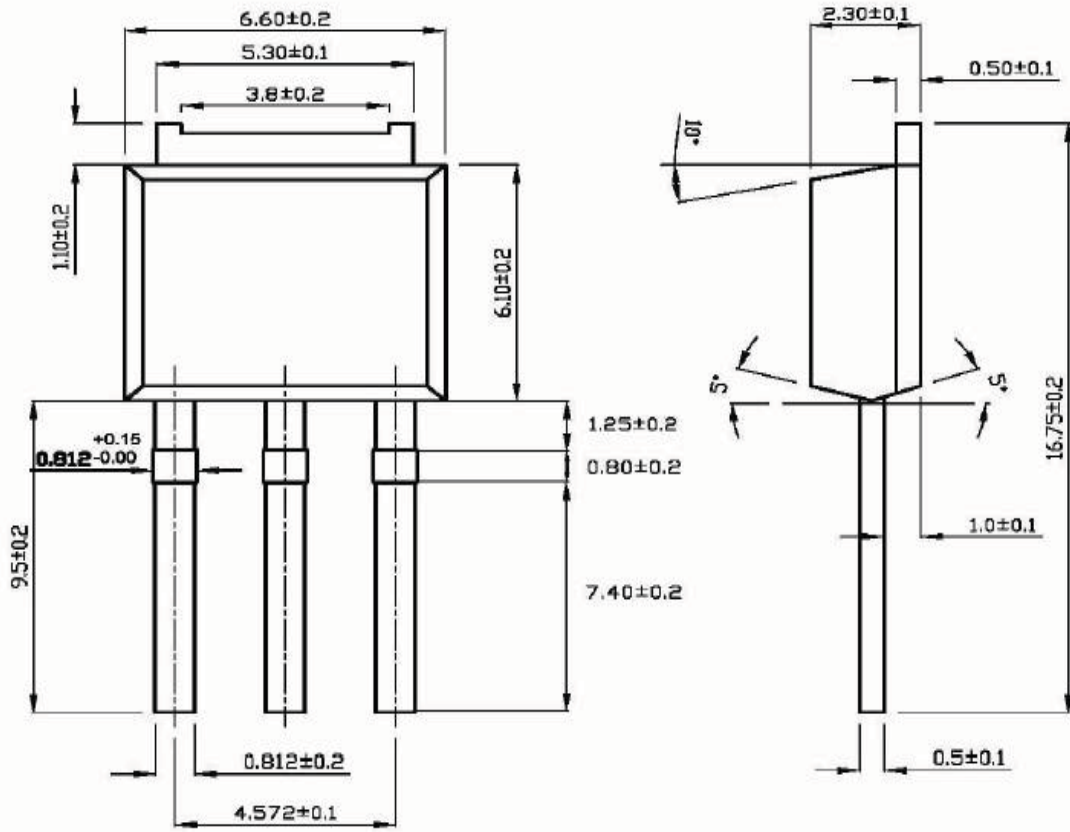

TO-252 Package Information

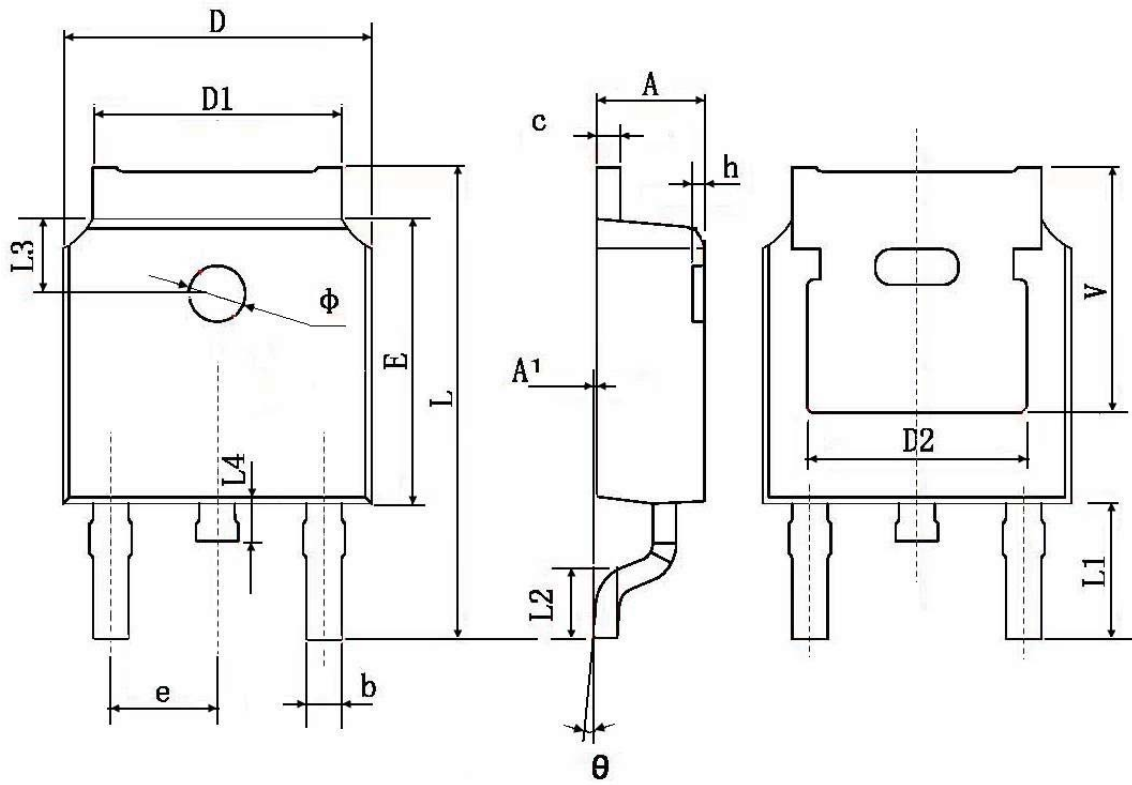

Symbol	Dimensions In Millimeters		Dimensions In Inches	
	Min.	Max.	Min.	Max.
A	2.200	2.400	0.087	0.094
A1	0.000	0.127	0.000	0.005
b	0.660	0.860	0.026	0.034
c	0.460	0.580	0.018	0.023
D	6.500	6.700	0.256	0.264
D1	5.100	5.460	0.201	0.215
D2	4.830 TYP.		0.190 TYP.	
E	6.000	6.200	0.236	0.244
e	2.186	2.386	0.086	0.094
L	9.800	10.400	0.386	0.409
L1	2.900 TYP.		0.114 TYP.	
L2	1.400	1.700	0.055	0.067
L3	1.600 TYP.		0.063 TYP.	
L4	0.600	1.000	0.024	0.039
Φ	1.100	1.300	0.043	0.051
θ	0°	8°	0°	8°
h	0.000	0.300	0.000	0.012
V	5.350 TYP.		0.211 TYP.	