

N-CHANNEL ENHANCEMENT MODE MOSFET

General Description

RMP2N60 is an N-channel enhancement mode MOSFET, which uses the self-aligned planar process and improved terminal technology, reducing the conduction loss, enhancing the avalanche energy.

MAIN CHARACTERISTICS

V_{DSS}	600	V
I_D	2	A
$R_{DS(ON)}$	3.5	Ω
C_{rss}	6.0	pF

FEATURES

- Low C_{rss}
- Low gate charge
- Fast switching
- Improved ESD capability
- Improved dv/dt capability
- 100% avalanche energy test

APPLICATIONS

- High efficiency switch mode power supplies
- Electronic lamp ballasts
- UPS

Package Marking And Ordering Information

Device	Device Package	Marking
RMP2N60IP	TO-251	2N60
RMP2N60LD	TO-252	2N60
RMP2N60TI	TO-220F	2N60
RMP2N60T2	TO-220	2N60

Symbol

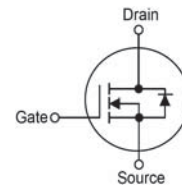

Package

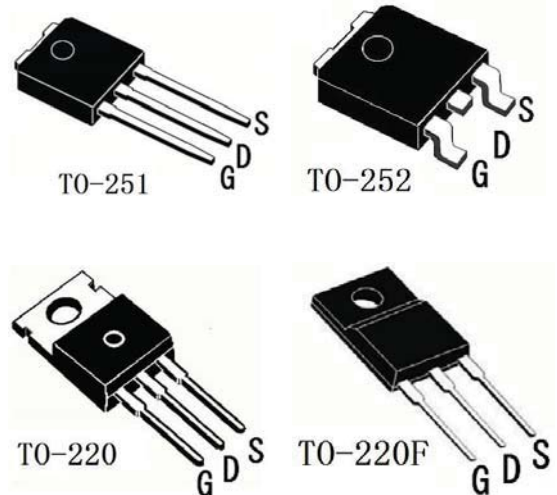

ABSOLUTE MAXIMUM RATINGS (T_c=25°C)

Parameter	Symbol		Value	Unit
Drain-Source Voltage	V _{DSS}		600	V
Continues Drain Current	I _D	T _c =25°C	2*	A
		T _c =100°C	1.3*	
Plused Drain Current (note 1)	I _{DM}		8	A
Gate-to-Source Voltage	V _{GS}		±30	V
Single Pulsed Avalanche Energy (note2)	E _{AS}		120	mJ
Avalanche Current (note 1)	I _{AR}		2.0	A
Repetitive Avalanche Energy (note 1)	E _{AR}		10	mJ
Peak Diode Recovery (note 3)	dv/dt		4.5	V/ns
Power Dissipation	P _D T _c =25°C	TO-251/TO-252	44	W
		TO-220	54	
		TO-220F	23	
Power Dissipation Derating Factor	P _{D(DF)} Above 25°C	TO-251/TO-252	0.39	W/°C
		TO-220	0.8	
		TO-220F	0.26	
Operating and Storage Temperature Range	T _J , T _{STG}		150, -55~+150	°C
Maximum Temperature for Soldering	T _L		300	°C

THERMAL CHARACTERIASTIC

Parameter	Symbol		Max	Unit
Thermal Resistance, Junction to Case	R _{th(j-c)}	TO-251/TO-252	2.87	°C/W
		TO-220	2.32	
		TO-220F	5.5	
Thermal Resistance, Junction to Ambient	R _{th(j-A)}	TO-251/TO-252	110	°C/W
		TO-220	62.5	
		TO-220F	62.5	

* Drain current limited by maximum junction temperature

ELECTRICAL CHARACTERISTICS

Off-Characteristics						
Parameter	Symbol	Tests Conditions	Min	Type	Max	Unit
Drain-Source Breakdown Voltage	BV_{DSS}	$I_D=250\mu A, V_{GS}=0V$	600	-	-	V
Breakdown Voltage Temperature Coefficient	$\frac{\Delta BV_{DSS}}{\Delta T_J}$	$I_D=250\mu A$, referenced to $25^\circ C$	-	0.7	-	V/ $^\circ C$
Zero Gate Voltage Drain Current	I_{DSS}	$V_{DS}=600V, V_{GS}=0V, T_C=25^\circ C$	-	-	1	μA
		$V_{DS}=480V, T_C=125^\circ C$	-	-	10	
Gate-body leakage current, forward	I_{GSSF}	$V_{DS}=0V, V_{GS}=30V$	-	-	100	nA
Gate-body leakage current, reverse	I_{GSSR}	$V_{DS}=0V, V_{GS}=-30V$	-	-	-100	nA

On-Characteristics						
Parameter	Symbol	Tests Conditions	Min	Type	Max	Unit
Gate Threshold Voltage	$V_{GS(th)}$	$V_{DS} = V_{GS}, I_D=250\mu A$	2.0	-	4.0	V
Static Drain-Source On-Resistance	$R_{DS(ON)}$	$V_{GS}=10V, I_D=1.0A$	-	3.5	4.5	Ω
Forward Transconductance	g_{fs}	$V_{DS} = 40V, I_D=1.0A$ (note4)	-	2.0	-	S

Dynamic Characteristics						
Parameter	Symbol	Tests Conditions	Min	Type	Max	Unit
Input capacitance	C_{iss}	$V_{DS}=25V, V_{GS}=0V, f=1.0MHz$	-	380	480	pF
Output capacitance	C_{oss}		-	40	52	pF
Reverse transfer capacitance	C_{rss}		-	6.0	8.0	pF

Switching Characteristics						
Parameter	Symbol	Tests Conditions	Min	Type	Max	Unit
Turn-On delay time	$t_{d(on)}$	$V_{DD}=300V, I_D=2A, R_G=25\Omega$ (note 4, 5)	-	16	40	ns
Turn-On rise time	t_r		-	50	110	ns
Turn-Off delay time	$t_{d(off)}$		-	40	80	ns
Turn-Off Fall time	t_f		-	45	95	ns
Total Gate Charge	Q_g	$V_{DS}=480V, I_D=2A, V_{GS}=10V$ (note 4, 5)	-	10	14	nC
Gate-Source charge	Q_{gs}		-	2.1	-	nC
Gate-Drain charge	Q_{gd}		-	5.5	-	nC

Drain-Source Diode Characteristics and Maximum Ratings						
Parameter	Symbol	Tests Conditions	Min	Type	Max	Unit
Maximum Continuous Drain-Source Diode Forward Current		I_S	-	-	2	A
Maximum Pulsed Drain-Source Diode Forward Current		I_{SM}	-	-	8	A
Drain-Source Diode Forward Voltage	V_{SD}	$V_{GS}=0V, I_S=2A$	-	-	1.4	V
Reverse recovery time	t_{rr}	$V_{GS}=0V, I_S=2A$ $di_f/dt=100A/\mu s$ (note 4)	-	260	-	ns
Reverse recovery charge	Q_{rr}		-	1.2	-	μC

Notes:

- 1: Pulse width limited by maximum junction temperature
- 2: $L=55mH, I_{AS}=2A, V_{DD}=50V, R_G=25\Omega$, Starting $T_J=25^\circ C$
- 3: $I_{SD} \leq 2A, di/dt \leq 300A/\mu s, V_{DD} \leq BV_{DSS}$, Starting $T_J=25^\circ C$
- 4: Pulse Test: Pulse Width $\leq 300\mu s$, Duty Cycle $\leq 2\%$
- 5: Essentially independent of operating temperature

RATING AND CHARACTERISTICS CURVES (RMP2N60IP THRU RMP2N60T2)

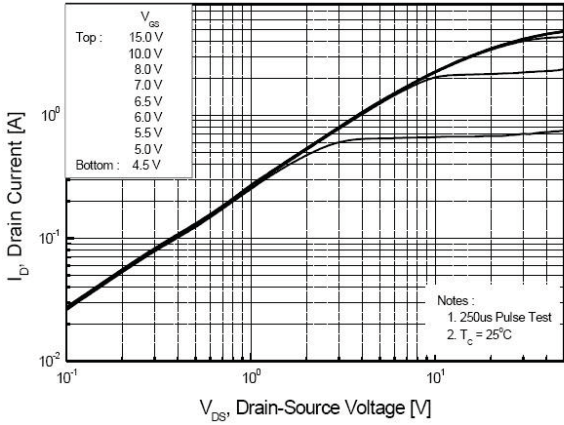

Fig. 1 On-State Characteristics

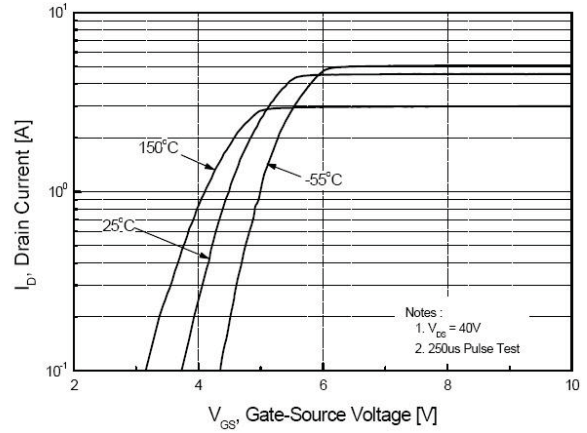

Fig. 2 Transfer Characteristics

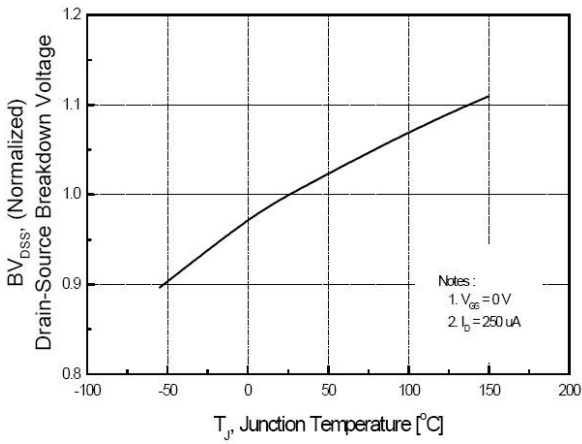

Fig. 3 Breakdown Voltage Variation vs Temperature

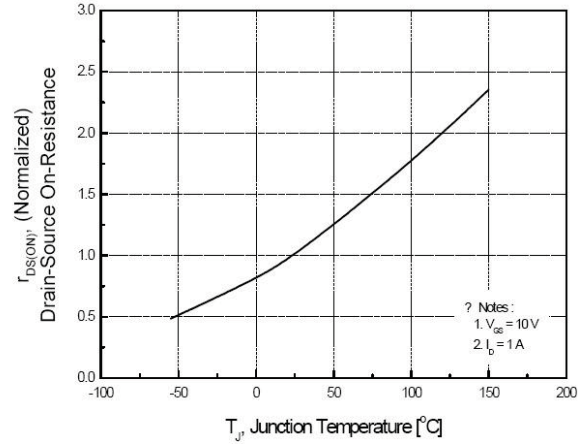
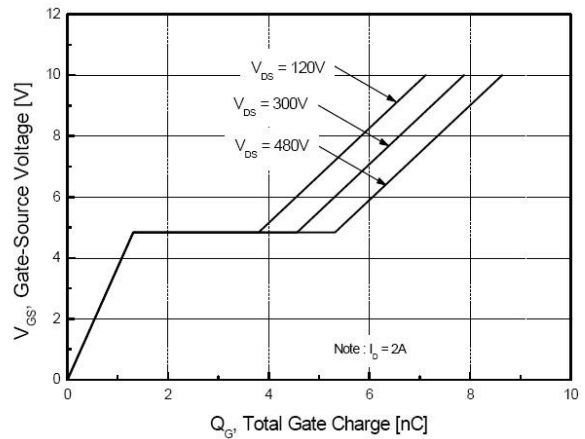
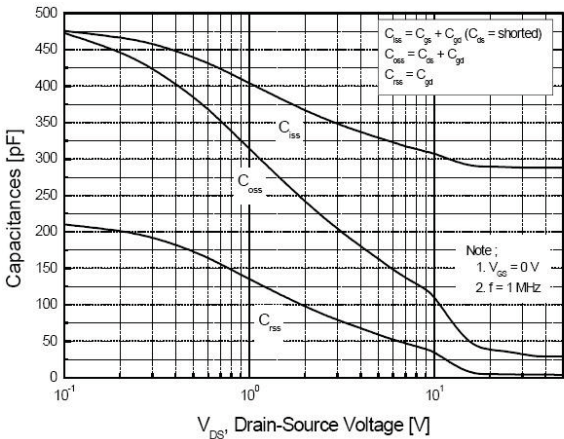

Fig. 4 On-Resistance Variation vs Temperature



RATING AND CHARACTERISTICS CURVES (RMP2N601P THRU RMP2N60T2)

Fig. 5 Capacitance Characteristics

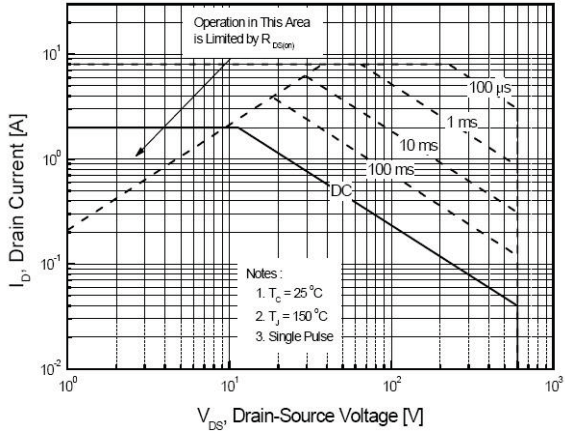

Fig. 7 Maximum Safe Operating Area

Fig. 6 Gate Charge Characteristics

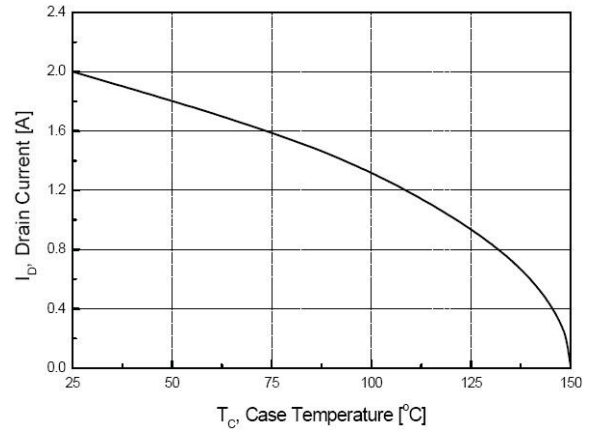

Fig. 8 Maximum Drain Current vs Case Temperature

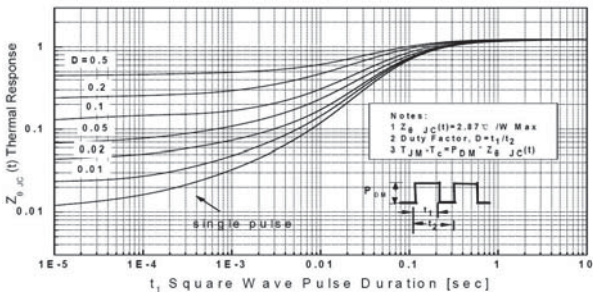

Fig. 9 Transient Thermal Response Curve (TO-251/TO-252)

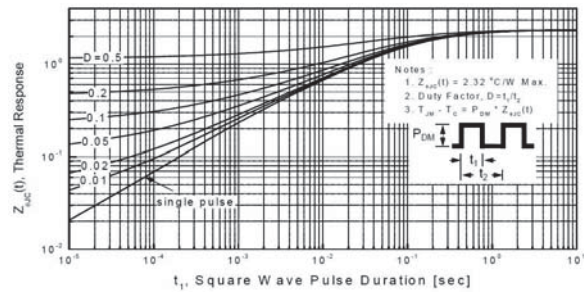

Fig. 10 Transient Thermal Response Curve (TO-220)

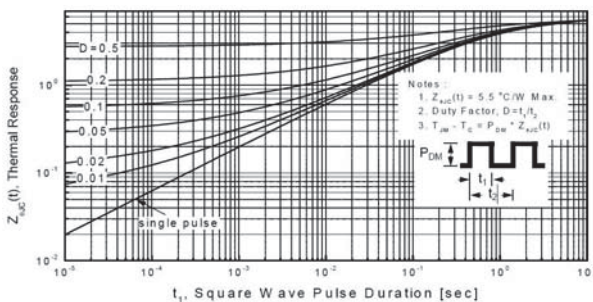

Fig. 11 Transient Thermal Response Curve (TO-220F)

TEST CIRCUITS AND WAVEFORMS

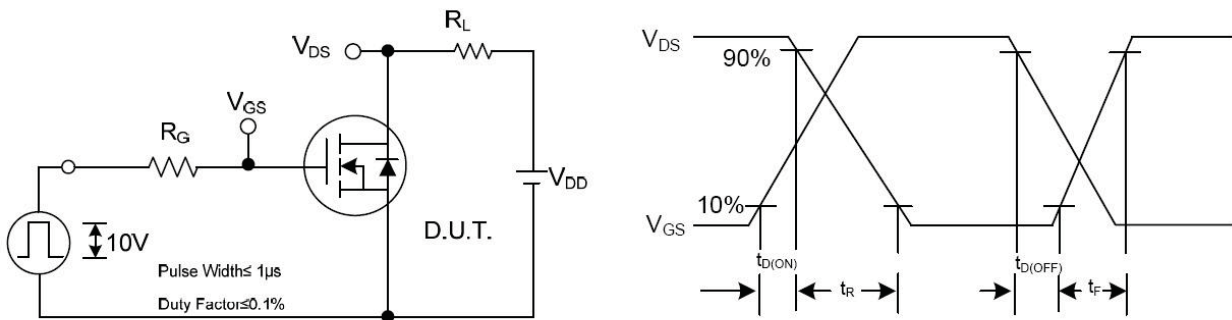

Fig.13 Resistive Switching Test Circuit & Waveforms

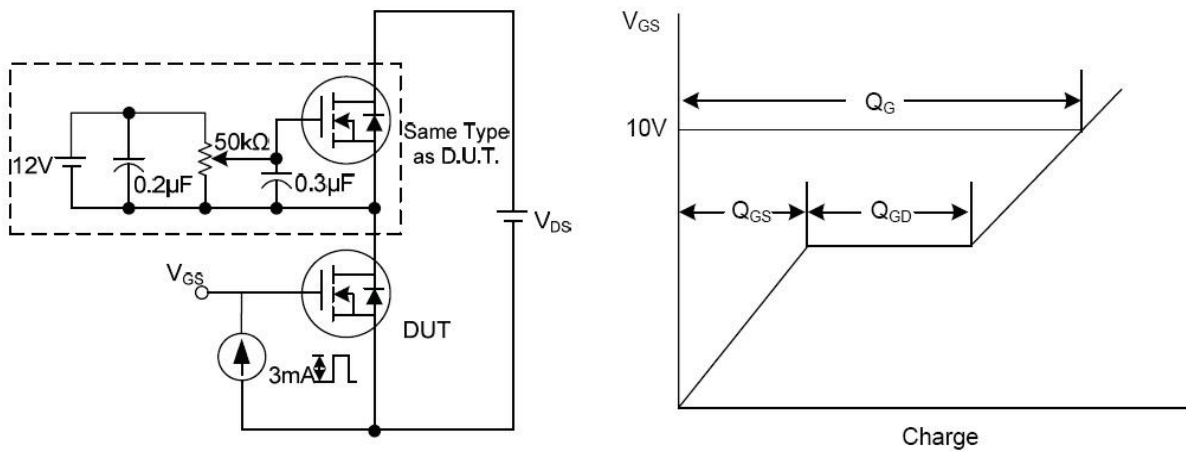

Fig.14 Gate Charge Test Circuit & Waveform

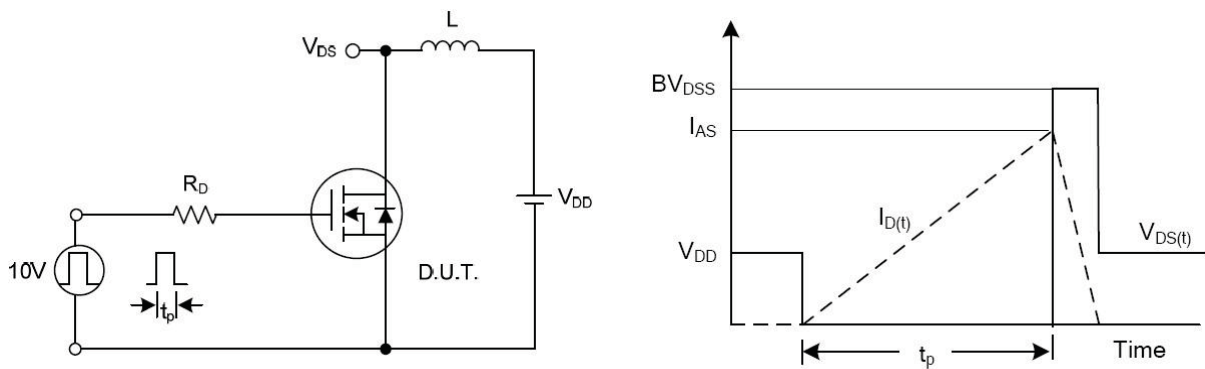
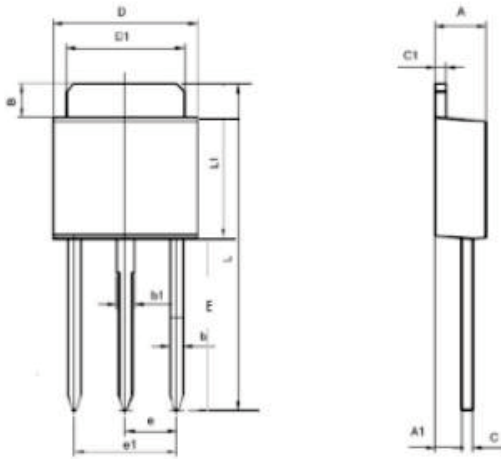

Fig.15 Unclamped Inductive Switching Test Circuit & Waveforms

TPACKAGE MECHANICAL DATA

T0-251 (1) 外形尺寸



单位: MM

SYMBOL	MILLIMETERS		SYMBOL	MILLIMETERS	
	Min	Max		Min	Max
A	2.2	2.4	E	7.9	8.3
B	1.2	1.6	L	14.25	15.25
C	0.40	0.6	b1	0.7	0.9
D	6.3	6.7	c1	0.4	0.6
L1	5.2	5.7	D1	5.2	5.4
b	0.5	0.7	e	2.30 TYP	
e1	4.5	4.7	A1	1.050	1.35

T0-251 (3) 外形尺寸

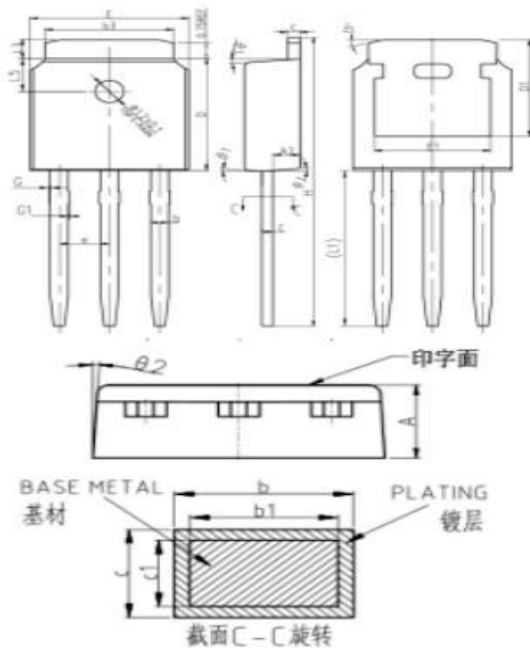

COMMON DIMENSIONS

SYMBOL	MM		
	MIN	NOM	MAX
A	2.20	2.30	2.38
A2	0.97	1.07	1.17
b	0.72	0.78	0.85
b1	0.71	0.76	0.81
b3	5.23	5.33	5.46
c	0.47	0.53	0.58
c1	0.46	0.51	0.56
D	6.00	6.10	6.20
D1	5.30REF		
E	6.50	6.60	6.70
E1	4.70	4.83	4.92
e	2.286BSC		
H	16.10	16.40	16.60
L1	9.20	9.40	9.60
L3	0.90	1.02	1.25
L5	1.70	1.80	1.90
θ1	5°	7°	9°
θ2	5°	7°	9°

T0-252 (1) 外形尺寸

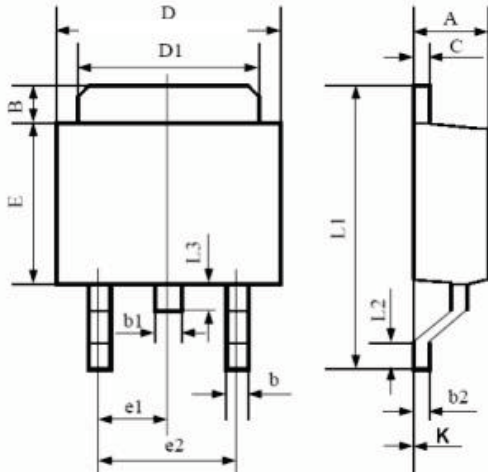

单位: MM

SYMBOL	MILLIMETERS		SYMBOL	MILLIMETERS	
	Min	Max		Min	Max
A	2.2	2.4	E	5.4	5.6
B	1.0	1.4	e1	2.25	2.35
b	0.5	0.7	e2	4.5	4.7
b1	0.7	0.9	L1	9.20	9.80
b2	0.40	0.6	L2	0.95	1.45
C	0.40	0.60	L3	0.95	1.1
D	6.3	6.7	K	-0.1	0
D1	5.2	5.4			

T0-220F 外形尺寸

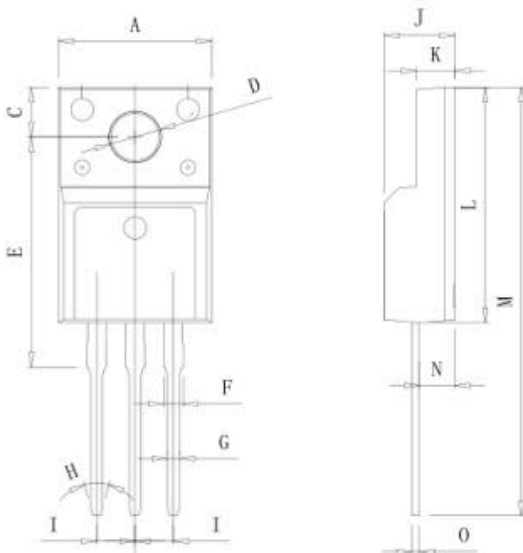

单位: MM

SYMBOL	MILLIMETERS		SYMBOL	MILLIMETERS	
	Min	Max		Min	Max
A	9.96	10.36	K	2.34	2.74
J	4.5	4.9	O	0.4	0.6
M	28	29.6	G	0.7	0.9
E	15.4	15.6	D	2.9	3.3
L	15.5	16.1	C	3.25	3.5
N	2.2	2.9	I	2.54 TYP	
F		1.4			

T0-220A 外形尺寸

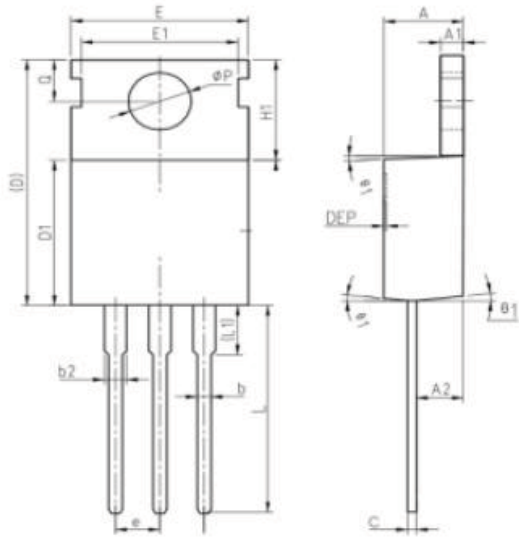

单位: MM

SYMBOL	MILLIMETERS		SYMBOL	MILLIMETERS	
	Min	Max		Min	Max
A	4.2	4.8	C	0.4	0.6
D1	8.9	9.4	b	0.7	0.9
E	9.7	10.3	A1	1.2	1.4
H1	6.3	6.9	Q	2.7	2.9
b2	1.27	1.43	A2	2.3	2.5
ϕP	3.6	3.9	e	2.54 TYP	
D	15.5	15.7			