

***N-CHANNEL ENHANCEMENT MODE MOSFET***

**General Description**

RMP4N70 is an N-channel enhancement mode MOSFET, which uses the self-aligned planar process and improved terminal technology, reducing the conduction loss, enhancing the avalanche energy.

**MAIN CHARACTERISTICS**

$V_{DSS}$	700	V
$I_D$	4.0	A
$R_{DS(ON)}$	2.5	$\Omega$
$Cr_{SS}$	8	pF

**FEATURES**

- Low  $Cr_{SS}$
- Low gate charge
- Fast switching
- Improved ESD capability
- Improved  $dv/dt$  capability
- 100% avalanche energy test

**APPLICATIONS**

- High efficiency switch mode power supplies
- Electronic lamp ballasts
- UPS

**Package Marking And Ordering Information**

Device	Device Package	Marking
RMP4N70IP	TO-251	4N70
RMP4N70LD	TO-252	4N70
RMP4N70T1	TO-220F	4N70
RMP4N70T2	TO-220	4N70

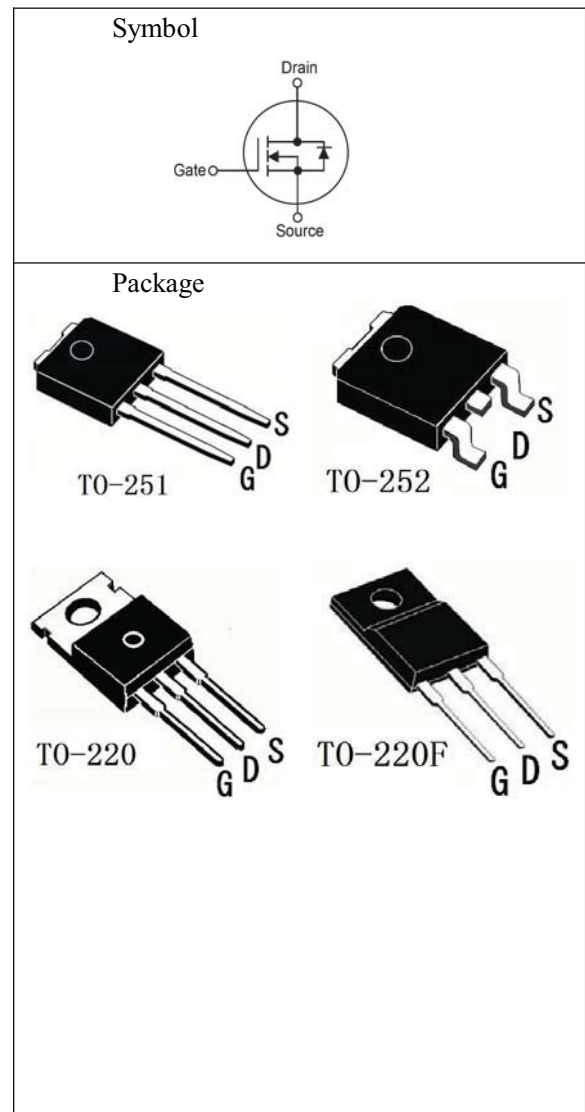

## ABSOLUTE MAXIMUM RATINGS (Tc=25°C)

Parameter	Symbol	Value	Unit
Drain-Source Voltage	V <sub>DSS</sub>	700	V
Continues Drain Current	I <sub>D</sub>	Tc=25°C	4*
		Tc=100°C	2.5*
Plused Drain Current (note 1)	I <sub>DM</sub>	16	A
Gate-to-Source Voltage	V <sub>GS</sub>	±30	V
Single Pulsed Avalanche Energy (note2)	E <sub>AS</sub>	218	mJ
Avalanche Current (note 1)	I <sub>AR</sub>	4.0	A
Repetitive Avalanche Energy (note 1)	E <sub>AR</sub>	10	mJ
Peak Diode Recovery (note3)	dv/dt	4.5	V/ns
Power Dissipation	P <sub>D</sub> Tc=25°C	TO-251/TO-252	51
		TO-220/TO-262	100
		TO-220F	33
Power Dissipation Derating Factor	P <sub>D(DF)</sub> Above 25°C	TO-251/TO-252	0.39
		TO-220/TO-262	0.8
		TO-220F	0.26
Operating and Storage Temperature Range	T <sub>J</sub> , T <sub>STG</sub>	150, -55~+150	°C
Maximum Temperature for Soldering	T <sub>L</sub>	300	°C

## THERMAL CHARACTERIASTIC

Parameter	Symbol	Max	Unit
Thermal Resistance, Junction to Case	R <sub>th(j-c)</sub>	TO-251/TO-252	2.5
		TO-220/TO-262	1.25
		TO-220F	3.79
Thermal Resistance, Junction to Ambient	R <sub>th(j-A)</sub>	TO-251/TO-252	83
		TO-220/TO-262	62.5
		TO-220F	62.5

\* Drain current limited by maximum junction temperature

## ELECTRICAL CHARACTERISTICS

Off-Characteristics						
Parameter	Symbol	Tests Conditions	Min	Type	Max	Unit
Drain-Source Breakdown Voltage	$BV_{DSS}$	$I_D=250\mu A, V_{GS}=0V$	700	-	-	V
Breakdown Voltage Temperature Coefficient	$\frac{\Delta BV_{DSS}}{\Delta T_J}$	$I_D=250\mu A$ , referenced to 25°C	-	0.7	-	V/°C
Zero Gate Voltage Drain Current	$I_{DSS}$	$V_{DS}=700V, V_{GS}=0V, T_C=25^\circ C$	-	-	1	$\mu A$
		$V_{DS}=560V, T_C=125^\circ C$	-	-	10	
Gate-body leakage current, forward	$I_{GSSF}$	$V_{DS}=0V, V_{GS}=30V$	-	-	100	nA
Gate-body leakage current, reverse	$I_{GSSR}$	$V_{DS}=0V, V_{GS}=-30V$	-	-	-100	nA

On-Characteristics						
Parameter	Symbol	Tests Conditions	Min	Type	Max	Unit
Gate Threshold Voltage	$V_{GS(th)}$	$V_{DS}=V_{GS}, I_D=250\mu A$	2.0	-	4.0	V
Static Drain-Source On-Resistance	$R_{DS(on)}$	$V_{GS}=10V, I_D=2.0A$	-	2.5	3.2	$\Omega$
Forward Transconductance	$g_{fs}$	$V_{DS}=40V, I_D=2.0A$ (note4)	-	4.0	-	S

Dynamic Characteristics						
Parameter	Symbol	Tests Conditions	Min	Type	Max	Unit
Input capacitance	$C_{iss}$	$V_{DS}=25V, V_{GS}=0V, f=1.0MHz$	-	574	694	pF
Output capacitance	$C_{oss}$		-	57	87	pF
Reverse transfer capacitance	$C_{rss}$		-	8	15	pF

Switching Characteristics						
Parameter	Symbol	Tests Conditions	Min	Type	Max	Unit
Turn-On delay time	$t_{d(on)}$	$V_{DD}=350V, I_D=4A, R_G=25\Omega$ (note 4, 5)	-	25	60	ns
Turn-On rise time	$t_r$		-	58	125	ns
Turn-Off delay time	$t_{d(off)}$		-	75	160	ns
Turn-Off Fall time	$t_f$		-	58	125	ns
Total Gate Charge	$Q_g$	$V_{DS}=560V, I_D=4A, V_{GS}=10V$ (note 4, 5)	-	30	35	nC
Gate-Source charge	$Q_{gs}$		-	3.8	-	nC
Gate-Drain charge	$Q_{gd}$		-	14	-	nC

Drain-Source Diode Characteristics and Maximum Ratings						
Parameter	Symbol	Tests Conditions	Min	Type	Max	Unit
Maximum Continuous Drain-Source Diode Forward Current		$I_S$	-	-	4	A
Maximum Pulsed Drain-Source Diode Forward Current		$I_{SM}$	-	-	16	A
Drain-Source Diode Forward Voltage	$V_{SD}$	$V_{GS}=0V, I_S=4A$	-	-	1.4	V
Reverse recovery time	$t_{rr}$	$V_{GS}=0V, I_S=4A$ $di_F/dt=100A/\mu s$ (note 4)	-	340	-	ns
Reverse recovery charge	$Q_{rr}$		-	2.7	-	$\mu C$

Notes:

- 1: Pulse width limited by maximum junction temperature
- 2:  $L=25mH, I_{AS}=4A, V_{DD}=50V, R_G=25\Omega$ , Starting  $T_J = 25^\circ C$
- 3:  $I_{SD} \leq 4A, di/dt \leq 300A/\mu s, V_{DD} \leq BV_{DSS}$ , Starting  $T_J = 25^\circ C$
- 4: Pulse Test: Pulse Width  $\leq 300\mu s$ , Duty Cycle  $\leq 2\%$
- 5: Essentially independent of operating temperature

# RATING AND CHARACTERISTICS CURVES (RMP4N70IP THRU RMP4N70T2)

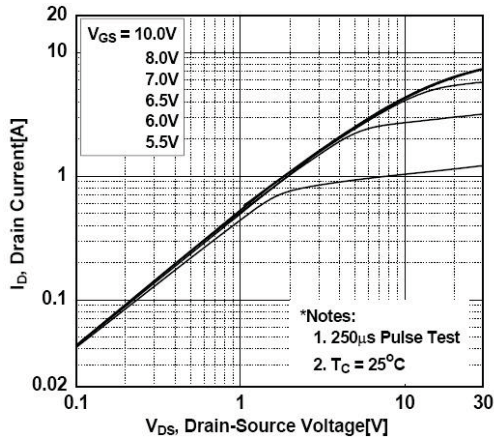

Fig. 1 On-State Characteristics

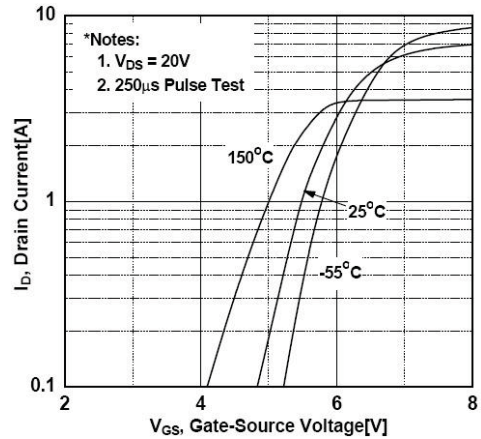

Fig. 2 Transfer Characteristics

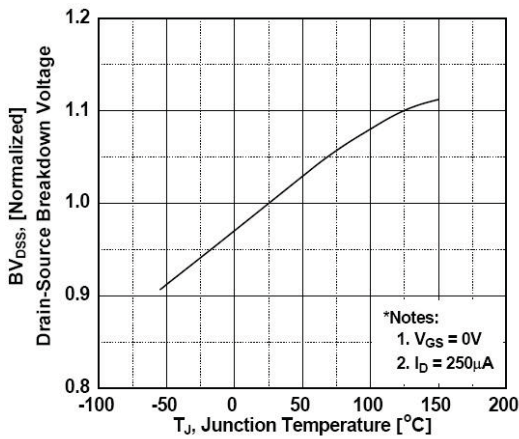

Fig. 3 Breakdown Voltage Variation vs Temperature

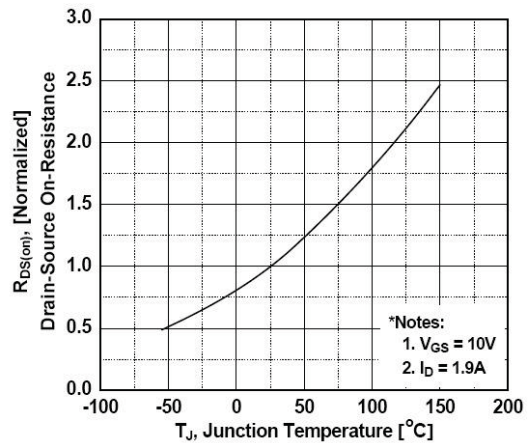

Fig. 4 On-Resistance Variation vs Temperature

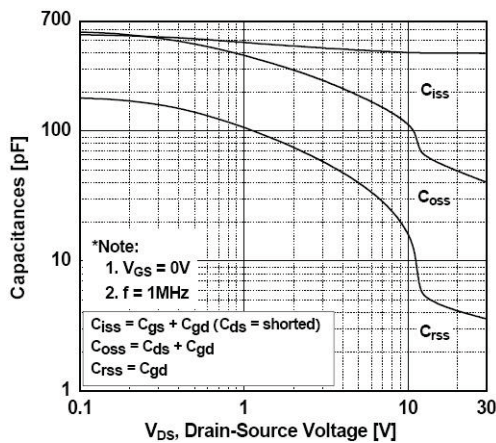

Fig. 5 Capacitance Characteristics

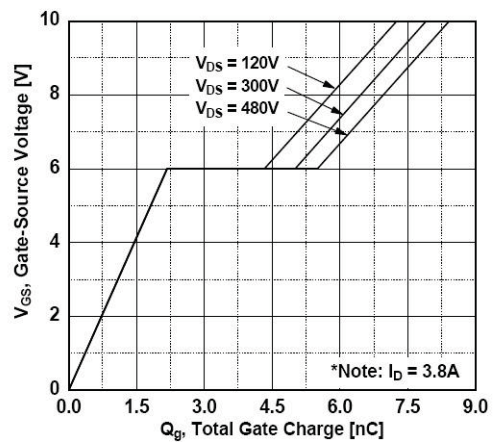

Fig. 6 Gate Charge Characteristics



# RATING AND CHARACTERISTICS CURVES (RMP4N70IP THRU RMP4N70T2)

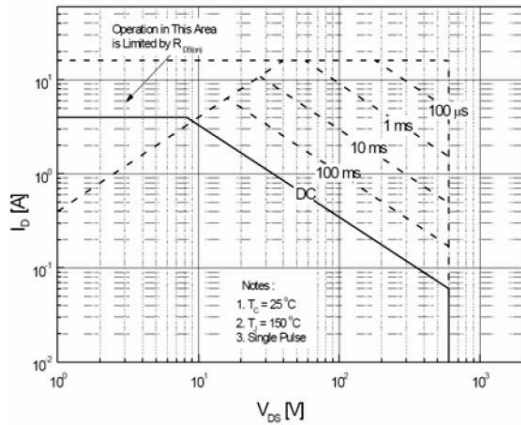

Fig. 7 Maximum Safe Operating Area

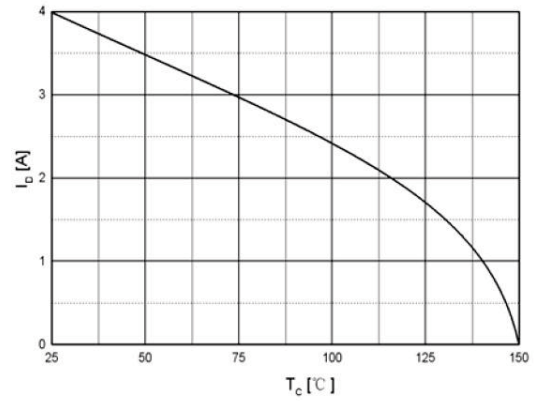

Fig. 8 Maximum Drain Current vs Case Temperature

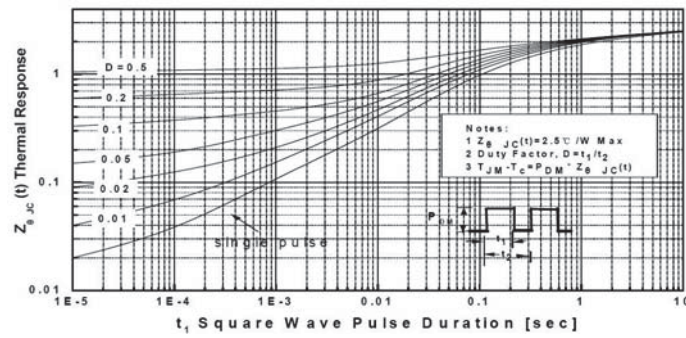

Fig. 9 Transient Thermal Response Curve (TO-251/TO-252)

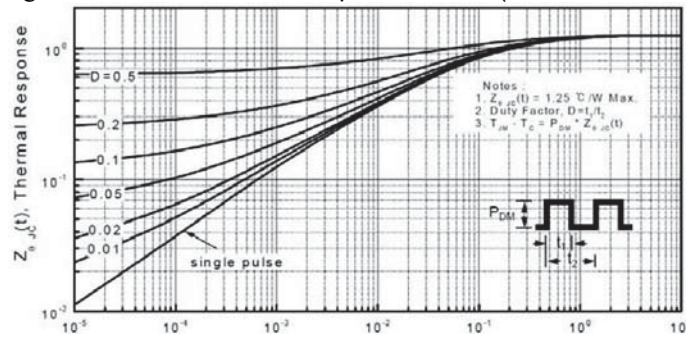

Fig. 10 Transient Thermal Response Curve (TO-220/TO-262)

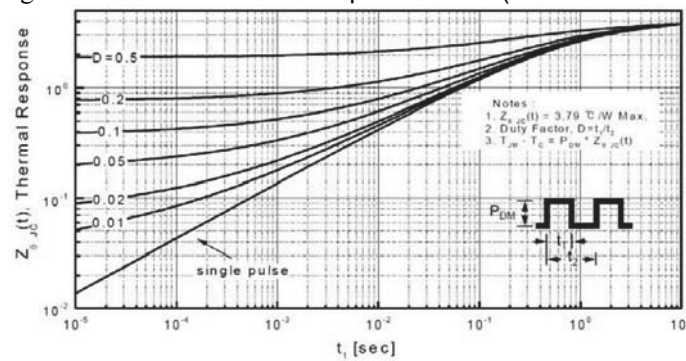

Fig. 11 Transient Thermal Response Curve (TO-220F)

## TEST CIRCUITS AND WAVEFORMS

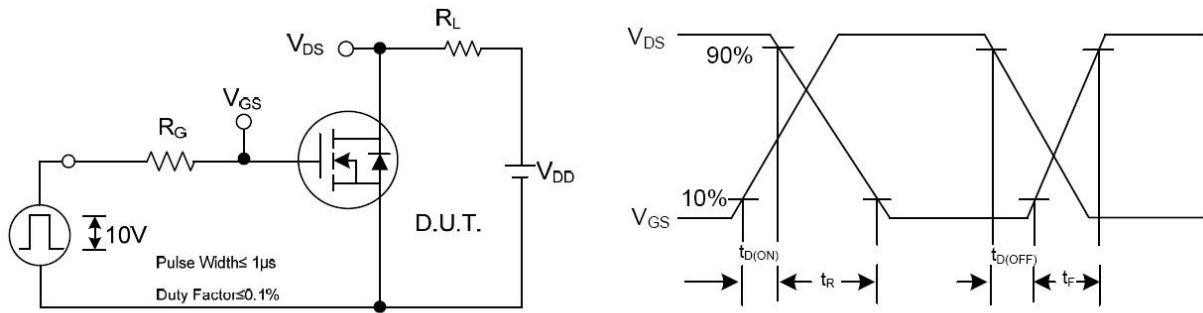

Fig.12 Resistive Switching Test Circuit & Waveforms

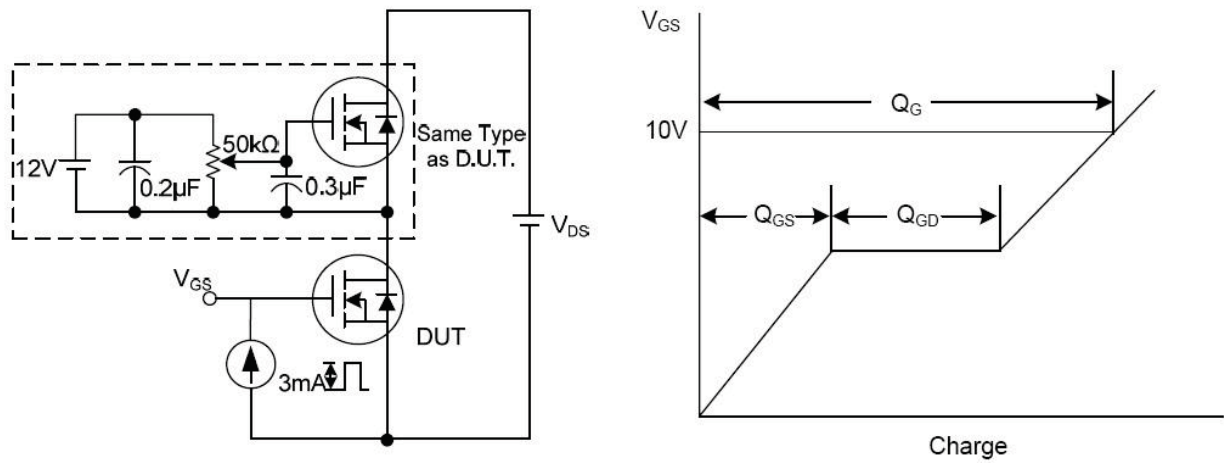

Fig.13 Gate Charge Test Circuit & Waveform

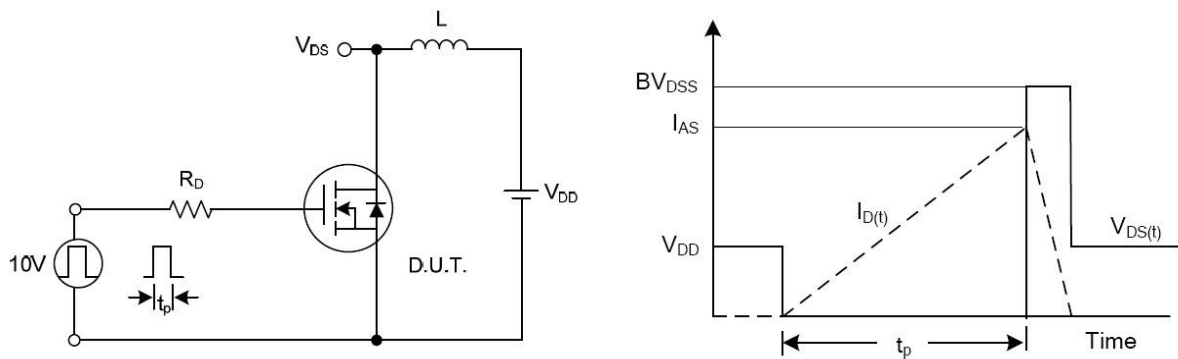
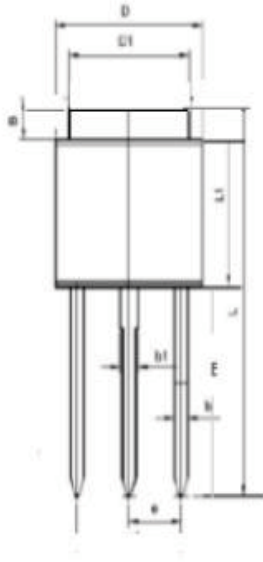

Fig.14 Unclamped Inductive Switching Test Circuit & Waveforms

# TPACKAGE MECHANICAL DATA

## T0-251 (2) 外形尺寸



单位: MM

SYMBOL	MILLIMETERS		SYMBOL	MILLIMETERS	
	Min	Max		Min	Max
A	2.0	2.6	E	8.0	9.6
B	0.9	1.3	L	14.25	17.25
C	0.4	0.6	b1	0.69	0.92
D	5.8	6.8	c1	0.4	0.6
L1	5.7	6.2	D1	4.8	5.8
A1	1.0	1.3	b	0.64	0.89
e	2.28 TYP				

## T0-252 (2) 外形尺寸

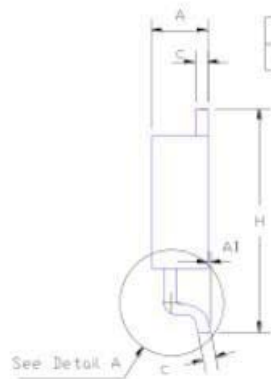
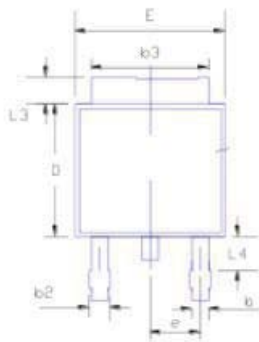

单位: MM

SYMBOL	MILLIMETERS		SYMBOL	MILLIMETERS	
	Min	Max		Min	Max
A	2.1	2.4	e	2.29 BSC	
A1	-	0.13	H	9.6	11.1
b	0.6	0.9	L3	0.8	1.4
b2	0.8	1.2	L4	0.6	1.1
b3	5.2	5.5	D	5.8	6.3
c	0.4	0.6	E	6.3	6.7



## T0-220F 外形尺寸

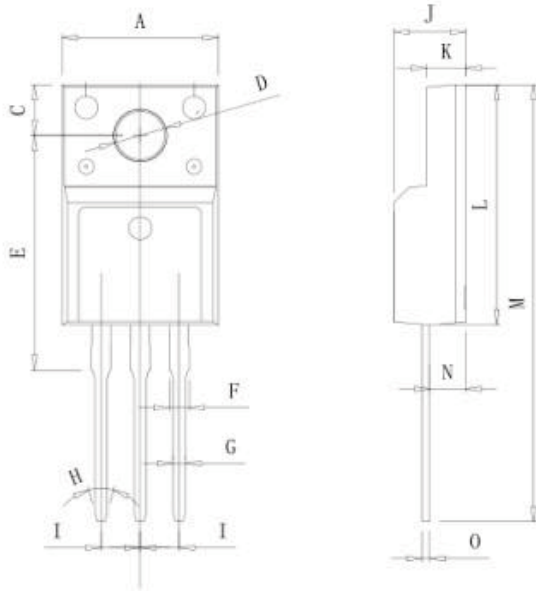

单位: MM

SYMBOL	MILLIMETERS		SYMBOL	MILLIMETERS	
	Min	Max		Min	Max
A	9.96	10.36	K	2.34	2.74
J	4.5	4.9	O	0.4	0.6
M	28	29.6	G	0.7	0.9
E	15.4	15.6	D	2.9	3.3
L	15.5	16.1	C	3.25	3.5
N	2.2	2.9	I	2.54 TYP	
F		1.4			

## T0-220A 外形尺寸

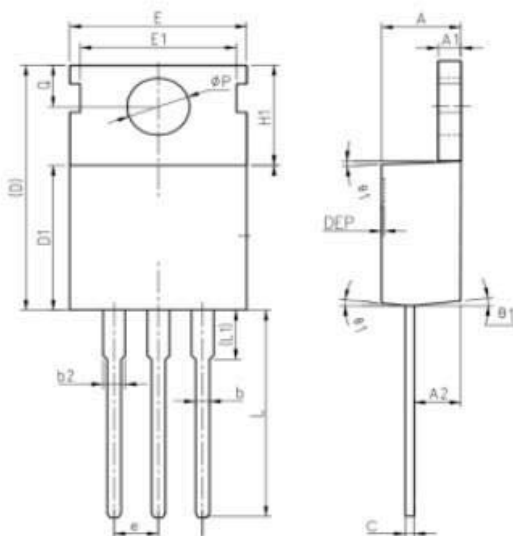

单位: MM

SYMBOL	MILLIMETERS		SYMBOL	MILLIMETERS	
	Min	Max		Min	Max
A	4.2	4.8	C	0.4	0.6
D1	8.9	9.4	b	0.7	0.9
E	9.7	10.3	A1	1.2	1.4
H1	6.3	6.9	Q	2.7	2.9
b2	1.27	1.43	A2	2.3	2.5
$\varnothing P$	3.6	3.9	e	2.54 TYP	
D	15.5	15.7			