

N-CHANNEL ENHANCEMENT MODE MOSFET

General Description

RMP6N60 is an N-channel enhancement mode MOSFET, which uses the self-aligned planar process and improved terminal technology, reducing the conduction loss, enhancing the avalanche energy.

MAIN CHARACTERISTICS

V_{DSS}	600	V
I_D	6.0	A
$R_{DS(ON)}$	1.5	Ω
C_{rss}	11	pF

FEATURES

- Low C_{rss}
- Low gate charge
- Fast switching
- Improved ESD capability
- Improved dv/dt capability
- 100% avalanche energy test

APPLICATIONS

- High efficiency switch mode power supplies
- Electronic lamp ballasts
- UPS

Package Marking And Ordering Information

Device	Device Package	Marking
RMP6N60IP	TO-251	6N60
RMP6N60LD	TO-252	6N60
RMP6N60TI	TO-220F	6N60
RMP6N60T2	TO-220	6N60

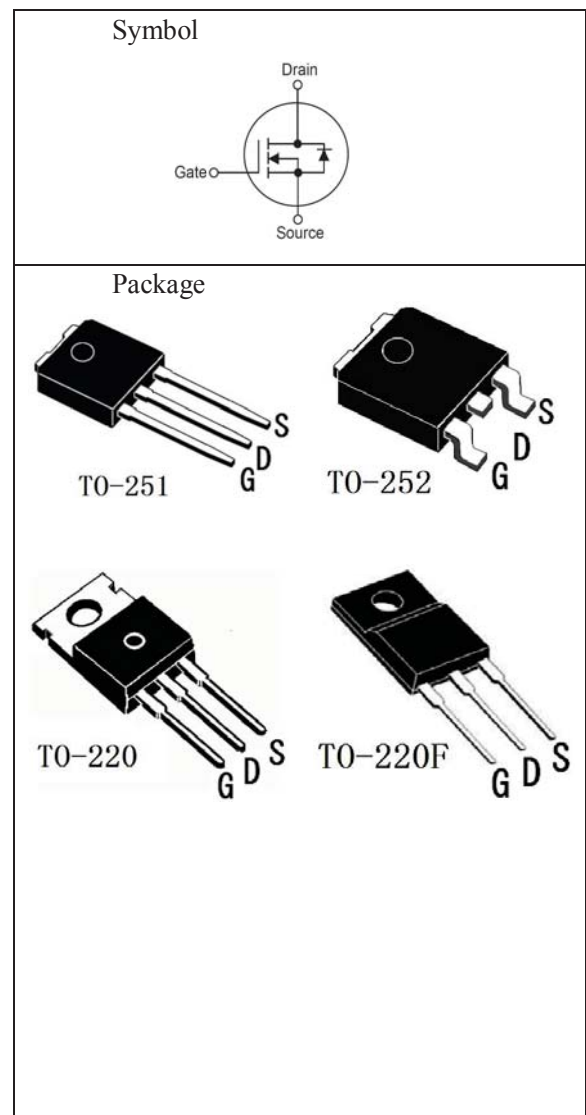

ABSOLUTE MAXIMUM RATINGS (Tc=25°C)

Parameter	Symbol		Value	Unit
Drain-Source Voltage	V _{DSS}		600	V
Continues Drain Current	I _D	Tc=25°C	6*	A
		Tc=100°C	2.8*	
Pulsed Drain Current (note 1)	I _{DM}		24	A
Gate-to-Source Voltage	V _{GS}		±30	V
Single Pulsed Avalanche Energy (note2)	E _{AS}		218	mJ
Avalanche Current (note 1)	I _{AR}		4.0	A
Repetitive Avalanche Energy (note 1)	E _{AR}		10	mJ
Peak Diode Recovery (note3)	dv/dt		4.5	V/ns
Power Dissipation	P _D Tc=25°C	TO-251/TO-252	51	W
		TO-220	100	
		TO-220F	33	
Power Dissipation Derating Factor	P _{D(DF)} Above 25°C	TO-251/TO-252	0.39	W/°C
		TO-220	0.8	
		TO-220F	0.26	
Operating and Storage Temperature Range	T _J , T _{STG}		150, -55~+150	°C
Maximum Temperature for Soldering	T _L		300	°C

THERMAL CHARACTERISTICS

Parameter	Symbol		Max	Unit
Thermal Resistance, Junction to Case	R _{th(j-c)}	TO-251/TO-252	2.5	°C/W
		TO-220	1.25	
		TO-220F	3.79	
Thermal Resistance, Junction to Ambient	R _{th(j-A)}	TO-251/TO-252	83	°C/W
		TO-220	62.5	
		TO-220F	62.5	

* Drain current limited by maximum junction temperature

ELECTRICAL CHARACTERISTICS

Off-Characteristics						
Parameter	Symbol	Tests Conditions	Min	Type	Max	Unit
Drain-Source Breakdown Voltage	BV_{DSS}	$I_D=250\mu A, V_{GS}=0V$	600	-	-	V
Breakdown Voltage Temperature Coefficient	$\Delta BV_{DSS}/\Delta T_J$	$I_D=250\mu A$, referenced to 25°C	-	0.7	-	V/°C
Zero Gate Voltage Drain Current	I_{DSS}	$V_{DS}=600V, V_{GS}=0V, T_C=25^\circ C$	-	-	1	μA
		$V_{DS}=480V, T_C=125^\circ C$	-	-	10	
Gate-body leakage current, forward	I_{GSSF}	$V_{DS}=0V, V_{GS}=30V$	-	-	100	nA
Gate-body leakage current, reverse	I_{GSSR}	$V_{DS}=0V, V_{GS}=-30V$	-	-	-100	nA

On-Characteristics						
Parameter	Symbol	Tests Conditions	Min	Type	Max	Unit
Gate Threshold Voltage	$V_{GS(th)}$	$V_{DS}=V_{GS}, I_D=250\mu A$	2.0	-	4.0	V
Static Drain-Source On-Resistance	$R_{DS(ON)}$	$V_{GS}=10V, I_D=3.0A$	-	1.5	1.65	Ω
Forward Transconductance	g_s	$V_{DS}=40V, I_D=3.0A$ (note4)	-	5	-	S

Dynamic Characteristics						
Parameter	Symbol	Tests Conditions	Min	Type	Max	Unit
Input capacitance	C_{iss}	$V_{DS}=25V, V_{GS}=0V, f=1.0MHZ$	-	800	1280	pF
Output capacitance	C_{oss}		-	75	145	pF
Reverse transfer capacitance	C_{rss}		-	11	18	pF

Switching Characteristics						
Parameter	Symbol	Tests Conditions	Min	Type	Max	Unit
Turn-On delay time	$t_{d(on)}$	$V_{DD}=300V, I_D=6A, R_G=25\Omega$ (note 4, 5)	-	25	60	ns
Turn-On rise time	t_r		-	58	125	ns
Turn-Off delay time	$t_{d(off)}$		-	75	160	ns
Turn-Off Fall time	t_f		-	58	125	ns
Total Gate Charge	Q_g	$V_{DS}=480V, I_D=6A, V_{GS}=10V$ (note 4, 5)	-	30	35	nC
Gate-Source charge	Q_{gs}		-	3.8	-	nC
Gate-Drain charge	Q_{gd}		-	14	-	nC

Drain-Source Diode Characteristics and Maximum Ratings						
Parameter	Symbol	Tests Conditions	Min	Type	Max	Unit
Maximum Continuous Drain-Source Diode Forward Current		I_S	-	-	6	A
Maximum Pulsed Drain-Source Diode Forward Current		I_{SM}	-	-	24	A
Drain-Source Diode Forward Voltage	V_{SD}	$V_{GS}=0V, I_S=6A$	-	-	1.4	V
Reverse recovery time	t_{rr}	$V_{GS}=0V, I_S=6A$ $dI_F/dt=100A/\mu s$ (note 4)	-	340	-	ns
Reverse recovery charge	Q_{rr}		-	2.7	-	μC

Notes:

- 1: Pulse width limited by maximum junction temperature
- 2: $I=25mH, I_{AS}=4A, V_{DD}=50V, R_G=25\Omega$, Starting $T_J=25^\circ C$
- 3: $I_{SD} \leq 6A, di/dt \leq 300A/\mu s, V_{DD} \leq BV_{DSS}$, Starting $T_J=25^\circ C$
- 4: Pulse Test: Pulse Width $\leq 300\mu s$, Duty Cycle $\leq 2\%$
- 5: Essentially independent of operating temperature

RATING AND CHARACTERISTICS CURVES (RMP6N60LD(IP)(TI)(T2))

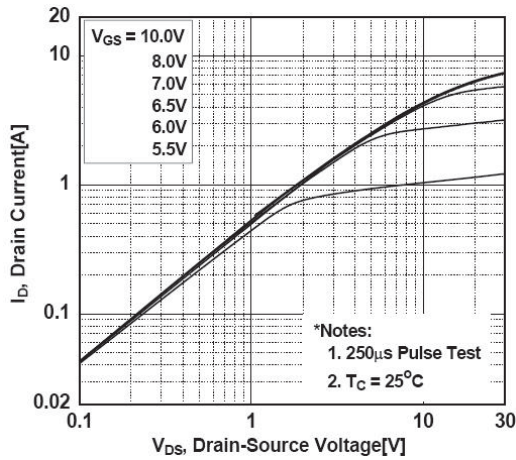

Fig. 1 On-State Characteristics

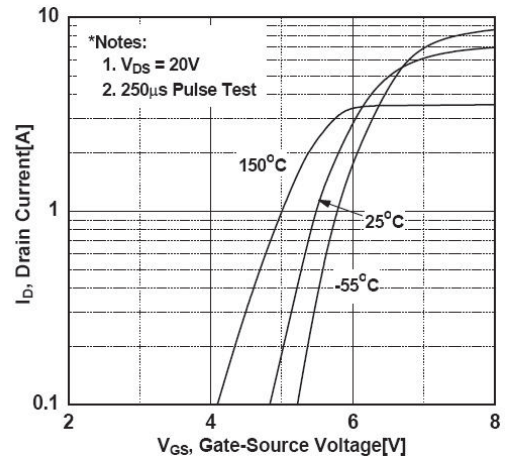

Fig. 2 Transfer Characteristics

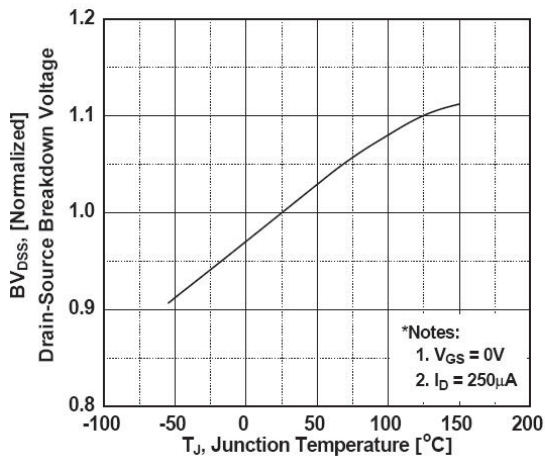

Fig. 3 Breakdown Voltage Variation vs Temperature

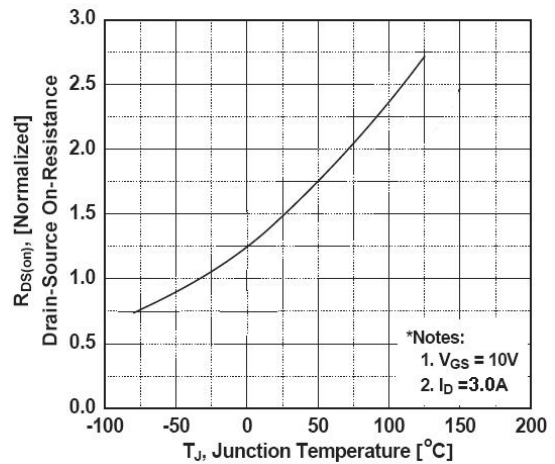

Fig. 4 On-Resistance Variation vs Temperature

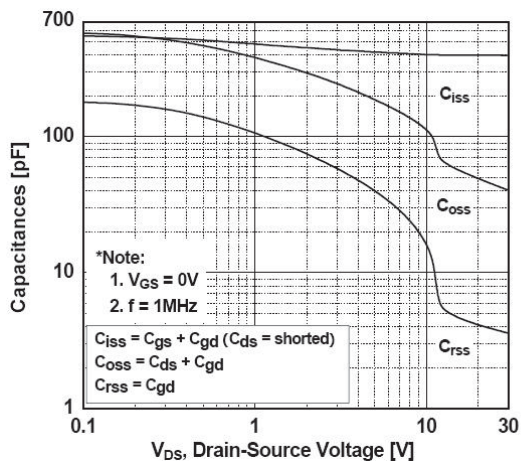

Fig. 5 Capacitance Characteristics

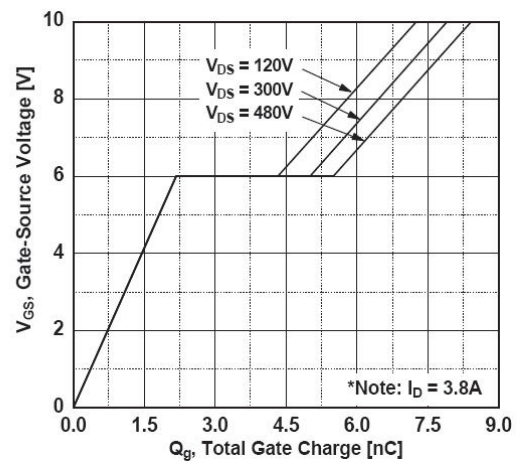

Fig. 6 Gate Charge Characteristics

RATING AND CHARACTERISTICS CURVES (RMP6N60LD(IP)(TI)(T2))

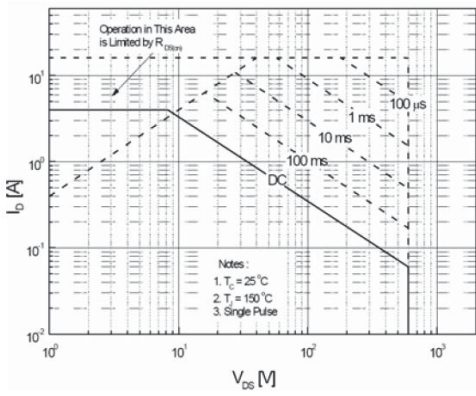

Fig. 7 Maximum Safe Operating Area

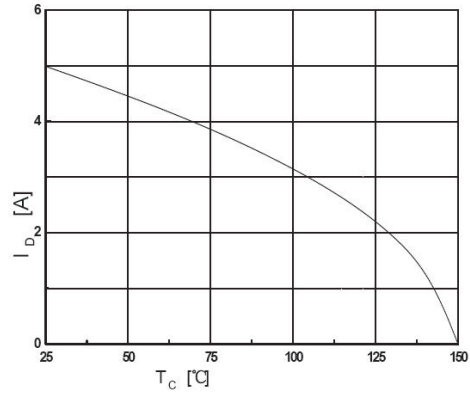

Fig. 8 Maximum Drain Current vs Case Temperature

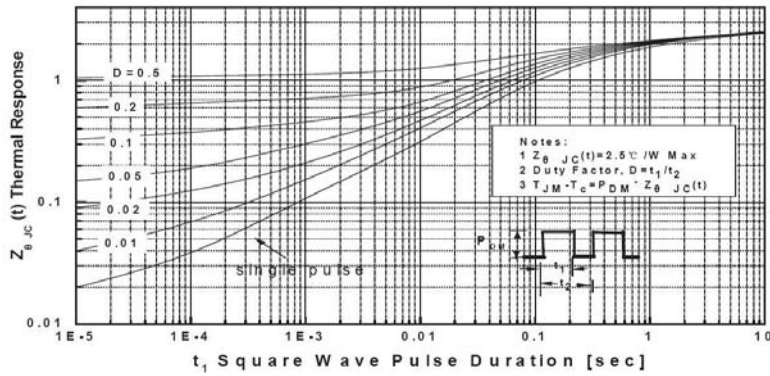

Fig. 9 Transient Thermal Response Curve (TO-251/TO-252)

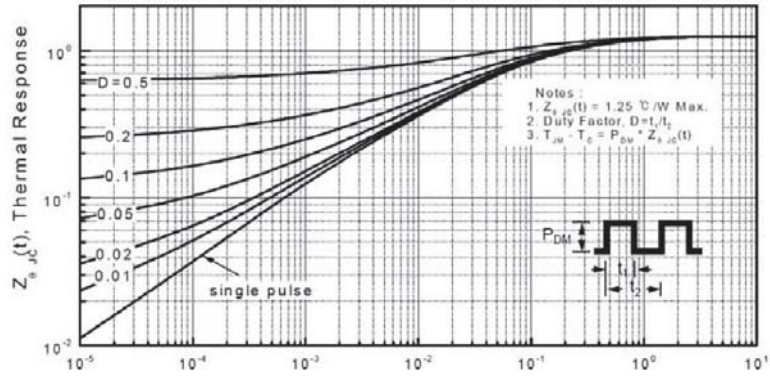

Fig. 10 Transient Thermal Response Curve (TO-220/TO-262)

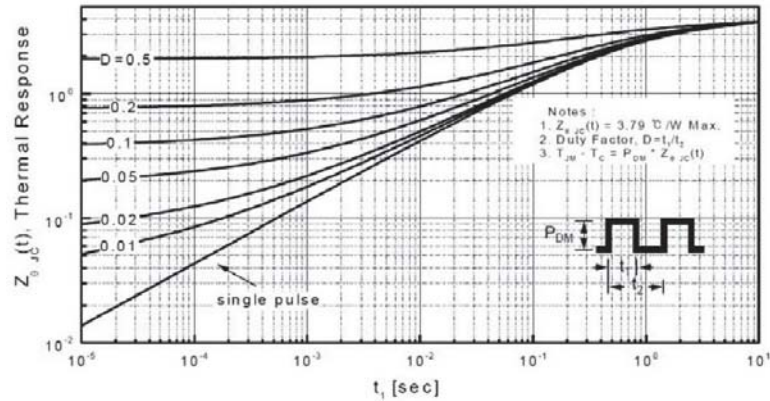

Fig. 11 Transient Thermal Response Curve (TO-220F)

TEST CIRCUITS AND WAVEFORMS

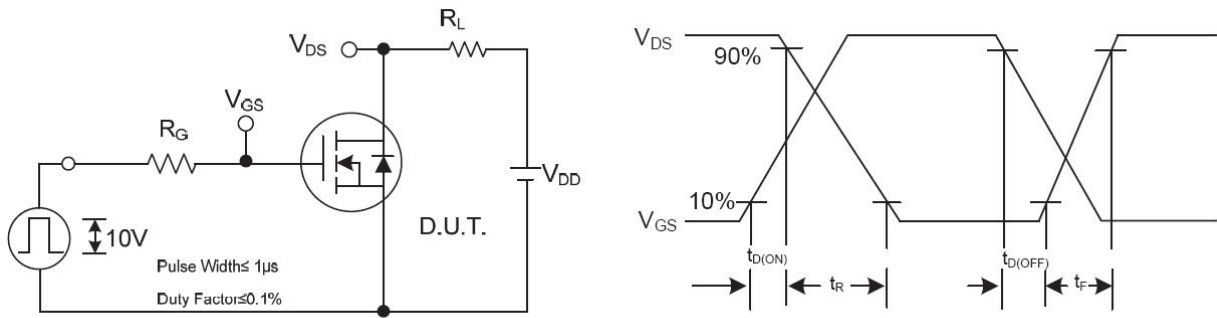

Fig.12 Resistive Switching Test Circuit & Waveforms

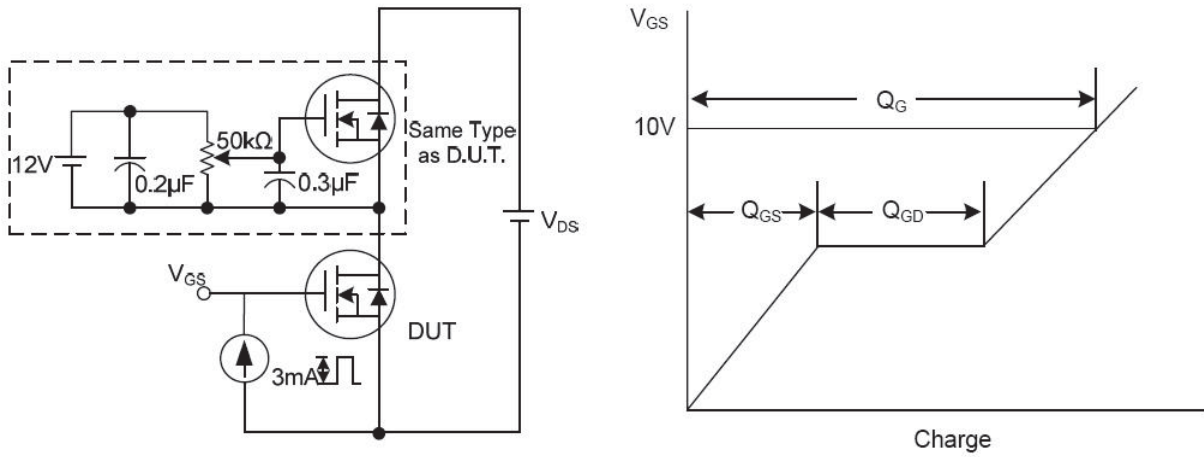

Fig.13 Gate Charge Test Circuit & Waveform

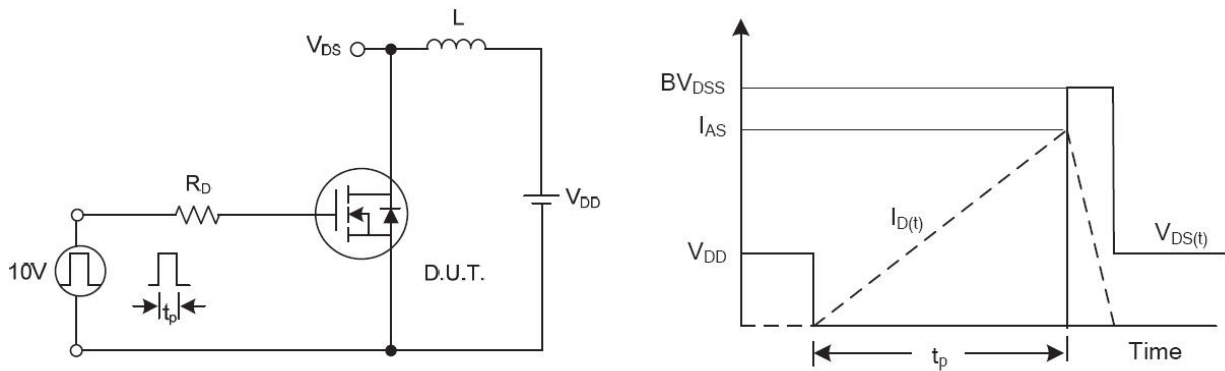
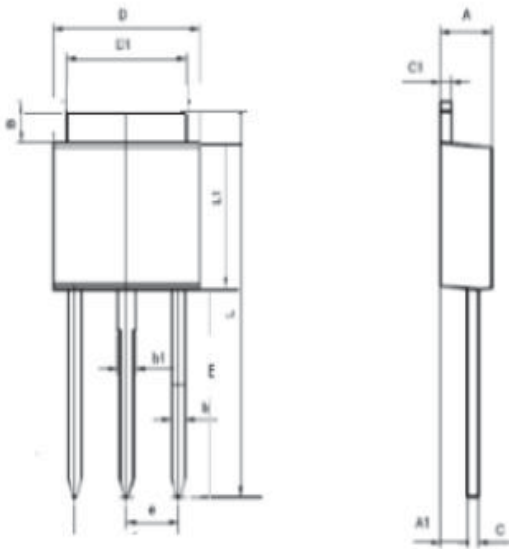

Fig.14 Unclamped Inductive Switching Test Circuit & Waveforms

PACKAGE MECHANICAL DATA

TO-251



SYMBOL	MILLIMETERS		SYMBOL	MILLIMETERS	
	Min	Max		Min	Max
A	2.0	2.6	E	8.0	9.6
B	0.9	1.3	L	14.25	17.25
C	0.4	0.6	b1	0.69	0.92
D	5.8	6.8	c1	0.4	0.6
L1	5.7	6.2	D1	4.8	5.8
A1	1.0	1.3	b	0.64	0.89
e	2.28 TYP				

TO-251

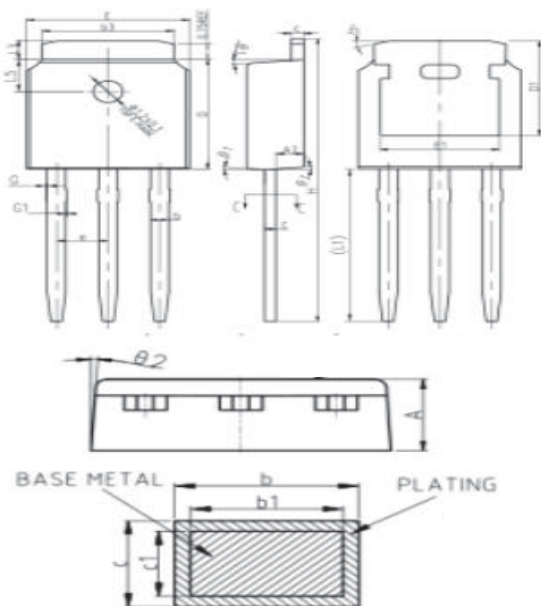

COMMON DIMENSIONS

SYMBOL	MM		
	MIN	NOM	MAX
A	2.20	2.30	2.38
A2	0.97	1.07	1.17
b	0.72	0.78	0.85
b1	0.71	0.76	0.81
b3	5.23	5.33	5.46
c	0.47	0.53	0.58
c1	0.46	0.51	0.56
D	6.00	6.10	6.20
D1	5.30REF		
E	6.50	6.60	6.70
E1	4.70	4.83	4.92
e	2.286BSC		
H	16.10	16.40	16.60
L1	9.20	9.40	9.60
L3	0.90	1.02	1.25
L5	1.70	1.80	1.90
θ 1	5°	7°	9°
θ 2	5°	7°	9°

T0-252

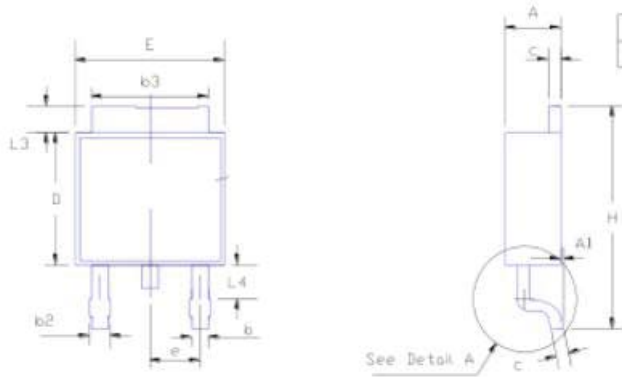

SYMBOL	MILLIMETERS		SYMBOL	MILLIMETERS	
	Min	Max		Min	Max
A	2.1	2.4	e	2.29 BSC	
A1	-	0.13	H	9.6	11.1
b	0.6	0.9	L3	0.8	1.4
b2	0.8	1.2	L4	0.6	1.1
b3	5.2	5.5	D	5.8	6.3
c	0.4	0.6	E	6.3	6.7

T0-220F

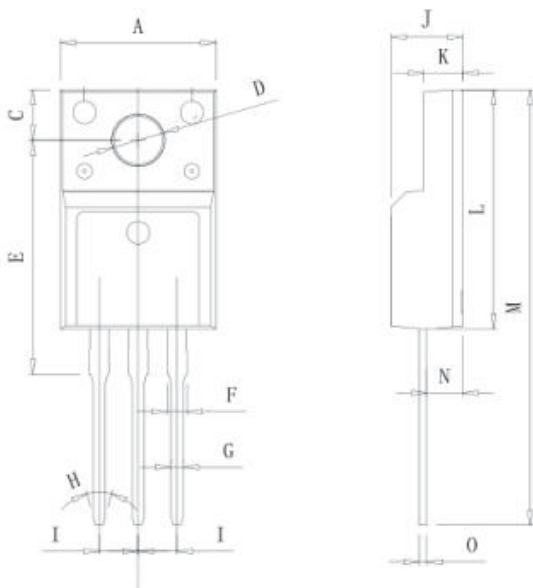

SYMBOL	MILLIMETERS		SYMBOL	MILLIMETERS	
	Min	Max		Min	Max
A	9.96	10.36	K	2.34	2.74
J	4.5	4.9	O	0.4	0.6
M	28	29.6	G	0.7	0.9
E	15.4	15.6	D	2.9	3.3
L	15.5	16.1	C	3.25	3.5
N	2.2	2.9	I	2.54 TYP	
F		1.4			

TO-220

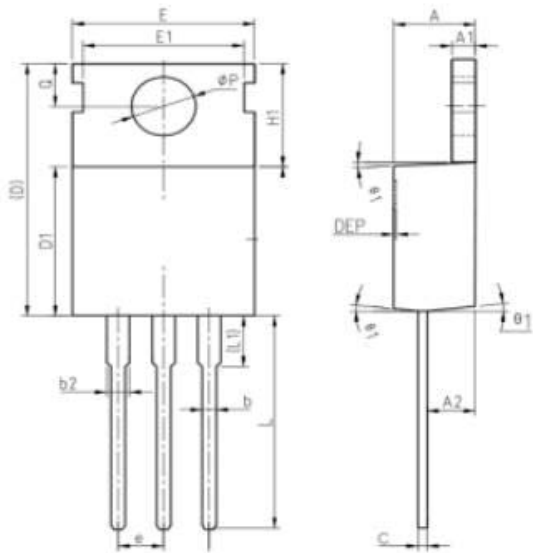

SYMBOL	MILLIMETERS		SYMBOL	MILLIMETERS	
	Min	Max		Min	Max
A	4.2	4.8	C	0.4	0.6
D1	8.9	9.4	b	0.7	0.9
E	9.7	10.3	A1	1.2	1.4
H1	6.3	6.9	Q	2.7	2.9
b2	1.27	1.43	A2	2.3	2.5
ϕP	3.6	3.9	e	2.54 TYP	
D	15.5	15.7			