

NOTES:

- HOUSING SHALL BE THERMOSETTING MOLDING MATERIAL PER MIL-M-14, TYPE SDG-F, COLOR: GREEN.
- SEALING GROMMET MATERIAL SHALL BE SILICONE RUBBER PER ZZ-R-765, COLOR: RED.
- SOCKET CONTACT SHALL BE COPPER ALLOY GOLD PLATED PER MIL-G-45204, TYPE II, GRADE C, CLASS I.
- STUD MATERIAL - CRES, PASSIVATED; HARDWARE - STEEL CADMIUM PLATED.
- SOCKET CONTACTS ARE OF CLOSED ENTRY TYPE AND DESIGNED TO COMPLY WITH TEST REQUIREMENTS OF MIL-C-39029 INCLUDING CRIMP TERMINATION.
- M22520/1-01 CRIMP TOOL AND M22520/1-02 POSITIONER SHALL BE USED TO TERMINATE SOCKET CONTACTS TO THEIR RESPECTIVE WIRE SIZES.
- M81969/14-03 AND TOOL(S) SHALL BE USED FOR INSERTING AND REMOVING WIRED SOCKET CONTACTS.
- ALL HARDWARE SUPPLIED UNASSEMBLED IN SEPERATE BAG WITHIN SOCKET PACKAGE.
- CONTACTS SUPPLIED UNASSEMBLED IN SEPERATE CONTAINER WITHIN SOCKET PACKAGE, SEE TABLE.
- WEIGHT: .176 LBS (80g) MAX., INCLUDING HARDWARE AND CONTACTS.
- INSTALLATION TORQUE REQUIREMENTS:
 THREAD SIZE 4-40 = 4 ±1.0 IN.-LBS.
 THREAD SIZE 10-32 = 18 ±1.0 IN.-LBS.
- THE SEALING GROMMET IS DESIGNED TO SEAL OVER THE FOLLOWING WIRE DIA.'S: SIZE 16 .065 MIN. TO .109 MAX.

REVISIONS				
REV	ECN	DESCRIPTION	DATE	APPD
-	1346	RELEASE	8/8/88	J.A.C.
A	1417	CHANGED PCD MARKING CHANGED NOTE 9 CHANGED NOTE 13		
B	2413	ADD "J" DESIG; CHG/REM INFO.		

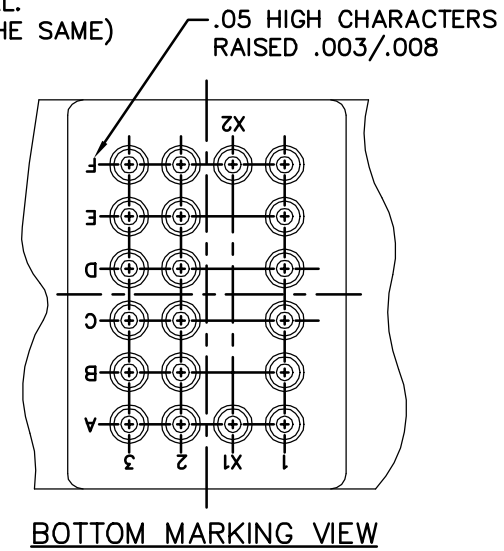
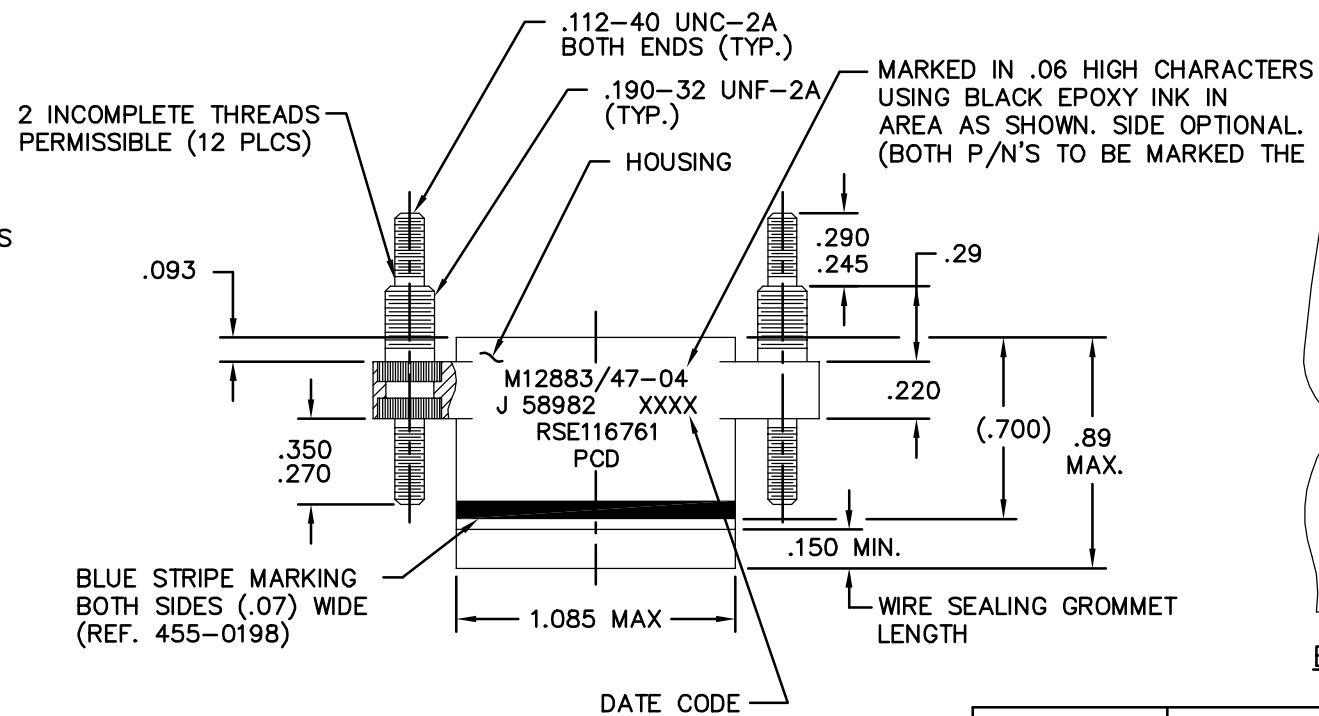
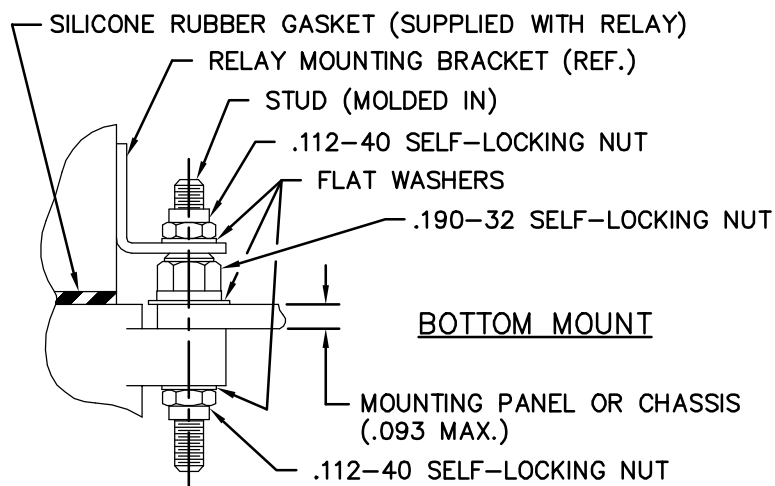
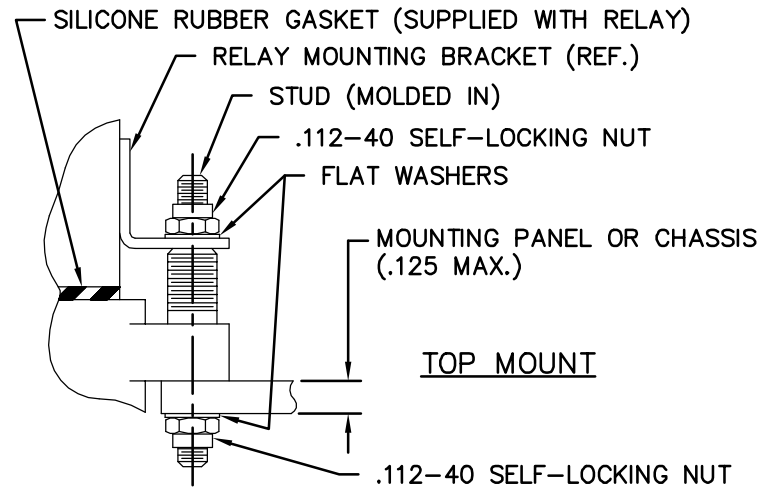
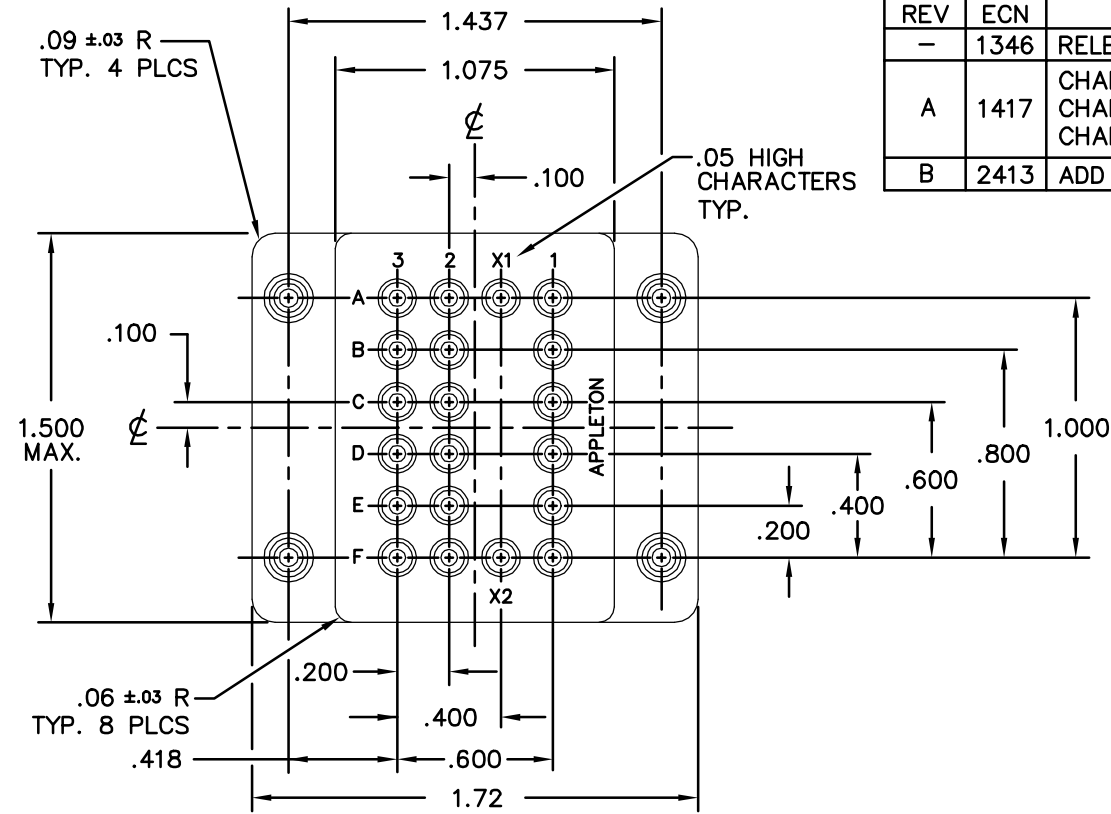

RSE116761	20 SZ. 16/16 SKT. CNT.	CNS126900
RSE116760		
PCD PART NO.	CONTACTS SUPPLIED	CONTACT PART NO.

TOLERANCES (INCHES)	THIRD ANGLE PROJECTION
.XX ± .01	
.XXX ± .005	
ANGLES ± 2°	
THIS DOCUMENT CONTAINS PROPRIETARY INFORMATION WHICH IS THE CONFIDENTIAL PROPERTY OF PRECISION CONNECTOR DESIGNS, INC.	

DRWN	M. CALLA 8/5/88
CHKD	J. CARDONE 8/8/88
ENGR	J. CARDONE 8/8/88
APPD	WM. KUBIN

2 TECHNOLOGY DR. PEABODY, MA. 01960 TITLE M12883/47-04 RELAY SOCKET 20 POSITION SIZE 16/16 CONTACTS			
SIZE	CODE NO.	DRAWING NO.	REV
C	58982	RSE116760	B
SCALE: 2 : 1		SHEET 1 OF 1	