

Wireless Power Transmitter for 5W/15W Solution

General Description

The RT3181A is a highly integrated and scalable solution for wireless power transmitter applications. The RT3181A is designed to support the major wireless power standards - WPC (Qi). The RT3181A can be configured to various type of transmitter in WPC definition.

The RT3181A supports fully integrated design for WPC LP A11 transmitter which could be powered from a 5V output of USB or AC adaptor in low power applications. The RT3181A is able to support WPC MP-A5 transmitter design with external power stage for medium power applications.

The RT3181A can be paired with a smart AC adapter from selected suppliers to provide reduced system cost and optimal efficiency over the range of power usage.

Applications

- Mobile Phones
- Phablets/Tablets
- Wearable Devices
- Medical and Industrial

Features

- High Integration with Internal H-Bridge Power Stage and Current Sense Amplifier, Optimized for LP-A11 Solution
- High Power with External Power Stage, Optimized for MP-A5 Solution
- No Current Transformer Required
- Low Quiescent Current Plus
 - Selectable Ping Cycle in Custom Applications
 - Low Current Sleep Mode Options Including "Off" State with Wake Up I/O Pin
- Programmable Thermal Protection
- Support Foreign Object Detection
- Notifications -
 - 1 Buzzer
 - 2 LEDs, Resistor Programmable
- I²C Host Applications Interface (Option)
- Internal Watchdog Timer
- 48-Lead WQFN Package

Simplified Application Circuit

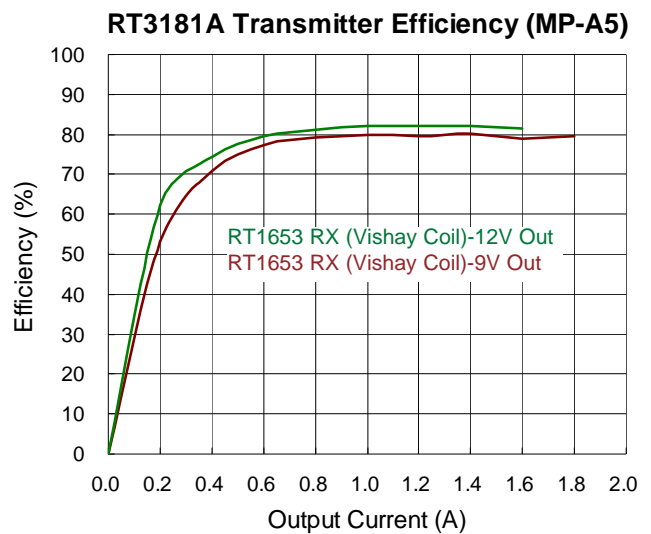
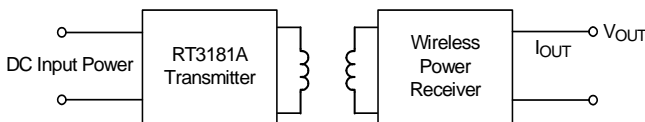

Ordering Information

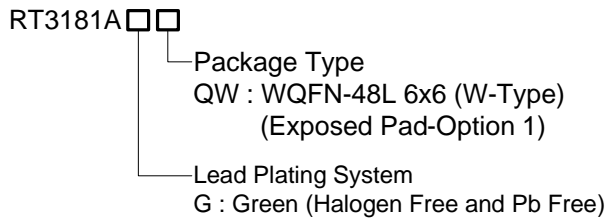

Note :

Richtek products are :

- ▶ RoHS compliant and compatible with the current requirements of IPC/JEDEC J-STD-020.
- ▶ Suitable for use in SnPb or Pb-free soldering processes.

Marking Information



RT3181AGQW : Product Number

YMDNN : Date Code

Pin Configuration

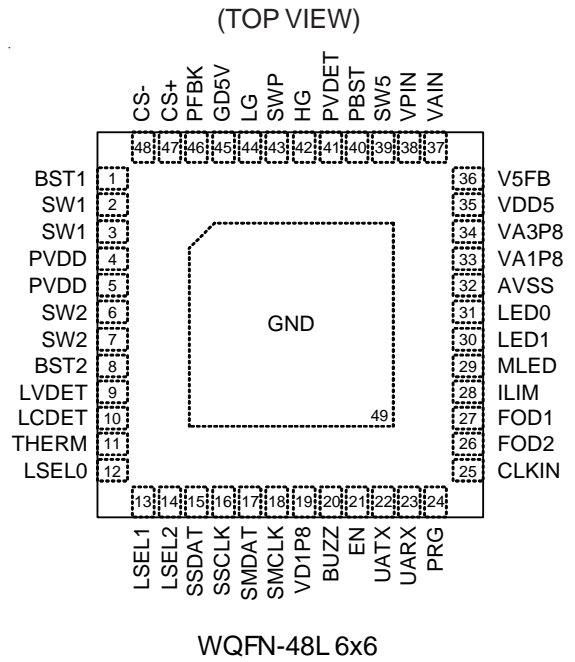

Functional Pin Description

Pin No.	Pin Name	Pin Function
1	BST1	Bootstrap supply input of H-Bridge power inverter.
2	SW1	First switch node of H-Bridge power inverter.
3	SW1	First switch node of H-Bridge power inverter.
4	PVDD	Power supply input of H-Bridge power inverter.
5	PVDD	Power supply input of H-Bridge power inverter.
6	SW2	Second switch node of H-Bridge power inverter.
7	SW2	Second switch node of H-Bridge power inverter.
8	BST2	Bootstrap supply input of H-Bridge power inverter.
9	LVDET	Coil voltage detection input.
10	LCDET	Coil current sense input.
11	THERM	Temperature detection input.
12	LSEL0	Coil select signal 0.
13	LSEL1	Coil select signal 1.
14	LSEL2	Coil select signal 2.
15	SSDAT	Slave I ² C data.
16	SSCLK	Slave I ² C clock.
17	SMDAT	Master I ² C data.
18	SMCLK	Master I ² C clock.
19	VD1P8	Digital core/IO power supply input.
20	BUZZ	Output for buzzer.
21	EN	Enable control input.
22	UATX	UART TX.
23	UARX	UART RX.
24	PRG	Reserved pin. Do not connect this pin to any power or ground.
25	CLKIN	Crystal oscillator input.
26	FOD2	Input for FOD threshold setting.
27	FOD1	Input for FOD threshold setting.
28	ILIM	Input for DC-DC MOSFET R _{ON} setting.
29	MLED	Input for LED mode selection.
30	LED1	Open drain LED driver.
31	LED0	Open drain LED driver.
32	AVSS	Reference ground.
33	VA1P8	1.8V LDO output.
34	VA3P3	3.3V LDO output.
35	VDD5	Power supply input for analog blocks.

Pin No.	Pin Name	Pin Function
36	V5FB	Feedback input of 5V buck converter.
37	VAIN	Main power input for analog blocks.
38	VPIN	Power input of 5V buck converter.
39	SW5	Switch node of 5V buck converter.
40	PBST	Bootstrap supply input for DC-DC controller.
41	PVDET	HS sense input for DC-DC controller.
42	HG	HS gate-driver output for DC-DC controller.
43	SWP	Switch node for DC-DC controller.
44	LG	LS gate-driver output for DC-DC controller.
45	GD5V	Gate driver supply input for H-Bridge driver.
46	PFBK	Feedback input for DC-DC controller.
47	CS+	Current sense positive input.
48	CS-	Current sense negative input.
49 (Exposed Pad)	GND	Ground. The exposed pad must be soldered to a large PCB and connected to GND for maximum power dissipation.

Functional Block Diagram

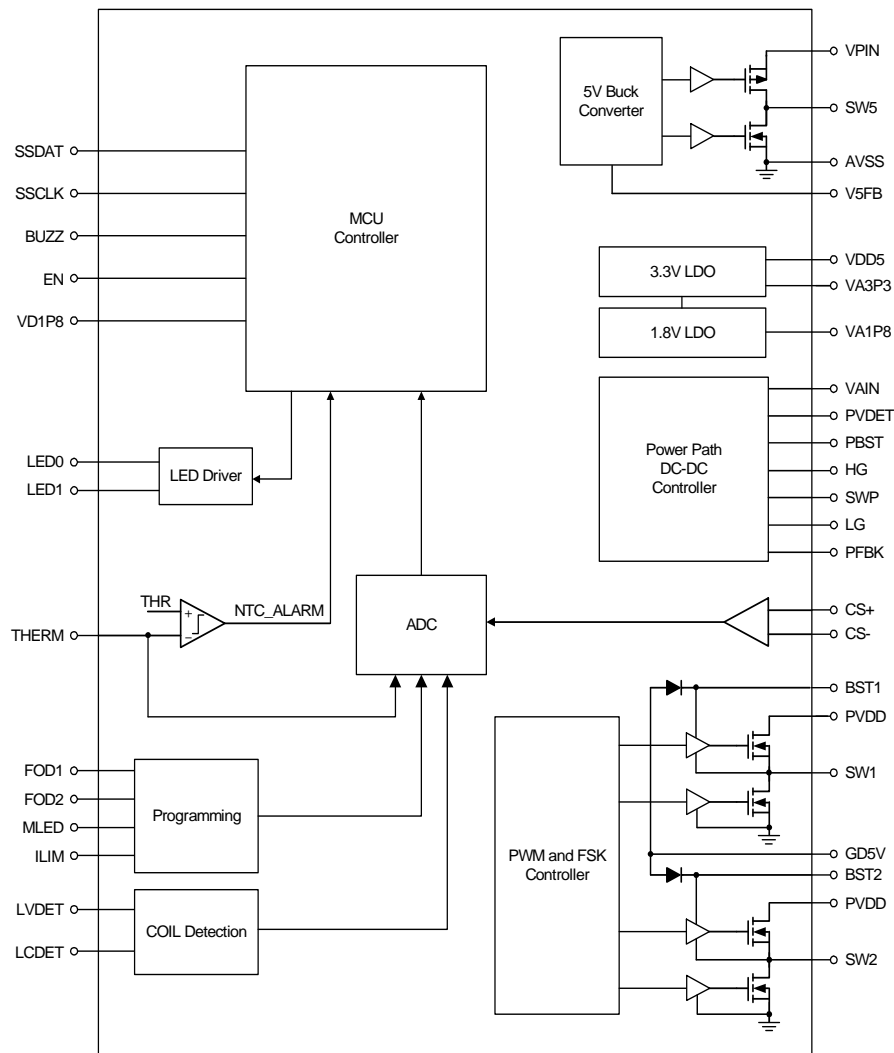

Operation

Internal Power Management

The internal power management system provides a 5V supply from Buck converter, a 3.3V supply from LDO and a 1.8V digital supply from LDO.

Power Path DC-DC Controller

The DC-DC Power Path converts the input voltage to a DC supply voltage for the power inverter to drive power transmitting coil. The DC-DC power path could be configured as a Buck converter or a Boost converter. It includes a current limit to prevent overloading of the wireless power receive chain.

H-Bridge Power Inverter

The H-Bridge power inverter converts DC input power to AC output power for driving coil. The power inverter is able to operate in a wide switching frequency range from 100kHz to 300kHz for different applications.

Microcontroller

The RT3181A device integrates a 32bit-microprocessor which allows designer to configure the transmitter to meet application requirements. The microprocessor monitors the input signals from ADC and control the output power via power path DC-DC controller and PWM controller.

Current Sense Amplifier

The current sense amplifier detects the voltage between CS+ pin and CS- pin which connected to an external current sense resistor. In general, the current sense resistor is connected to the input of power inverter.

OTP (Over-Temperature Protection)

The OTP function shuts down the power stage when the junction temperature exceeds a certain threshold. Once the junction temperature cools down, the receiver will automatically resume operating.

Absolute Maximum Ratings (Note 1)

- Input Voltage, VAIN, VPIN, SW5, PVDET, HG, SWP, LG, PFBK, CS+, CS- ----- -0.3V to 20V
- Input Voltage, PVDD, SW1, SW2 ----- -0.3V to 13.2V
- Input Voltage, LVDET, LCDET, THERM, CLKIN, FOD1, FOD2, ILIM, MLED, LED0, LED1, VDD5, V5FB, GD5V ----- -0.3V to 5.5V
- Input Voltage, PBST-SWP, BST1-SW1, BST2-SW2 ----- -0.3V to 5.5V
- Input Voltage, LSEL0, LSEL1, LSEL2, SSDAT, SSCLK, SMDAT, SMCLK, VD1P8, BUZZ, EN, UATX, UARX ----- -0.3V to 1.98V
- Input Current, PVDD ----- 2A
- Output Current, SW1, SW2 ----- 2A
- Power Dissipation, P_D @ T_A = 25°C
WQFN-48L 6x6 ----- 3.73W
- Package Thermal Resistance (Note 2)
WQFN-48L 6x6, θ_{JA} ----- 26.8°C/W
- Lead Temperature (Soldering, 10sec.) ----- 260°C
- Junction Temperature ----- 150°C
- Storage Temperature Range ----- -65°C to 150°C
- ESD Susceptibility (Note 3)
Human Body Model (HBM) ----- 2kV

Recommended Operating Conditions (Note 4)

- Supply Input Voltage Range, VAIN ----- 5V to 19V
- Input Voltage, PVDD ----- 5V to 12V
- Junction Temperature Range ----- -40°C to 125°C
- Ambient Temperature Range ----- -40°C to 85°C

Electrical Characteristics

(VAIN = VPIN = VDD5 = PVDD = GD5V = 5V, VD1P8 = 1.8V, T_A = 25°C, unless otherwise specified)

Parameter	Symbol	Test Conditions	Min	Typ	Max	Unit
VAIN Under-Voltage Lockout Threshold	V _{UVLO}	VAIN rising : 0 ≥ 5V	3	3.15	3.3	V
VAIN UVLO Hysteresis	V _{UVLO_HYS}	VAIN falling : 5V ≥ 0V	--	300	--	mV
Quiescent Current	I _Q	No coil, 200kHz switching at SW1, SW2	--	2	--	mA
Standby Current (Pinging)	I _{STB}		--	15	--	mA
Sleep Mode Current (No Pinging)	I _{SLEEP}		--	0.35	--	mA
Internal Regulator						
VDD5 Input Voltage	VDD5		4.5	5.0	5.5	V
5V Buck Converter Feedback Reference	V _{5FB}		--	5.0	--	V

Parameter	Symbol	Test Conditions	Min	Typ	Max	Unit
VA3P3 Output Voltage	VA3P3	LOAD = 20mA	2.97	3.3	3.63	V
3.3V Output Current	I _{33V}		0	--	50	mA
VA1P8 Output Voltage	VA1P8	LOAD = 40mA	1.62	1.8	1.96	V
1.8V Output Current	I _{18V}		0	--	100	mA
Power Path DC-DC Controller (Buck Mode)						
Quiescent Supply Current	I _{Q_BUCK}	Not connect to external pass device (Note 5)	--	--	2	mA
Shutdown Supply Current	I _{SD_BUCK}	(Note 5)	--	1	10	μA
Feedback Reference Voltage	V _{FB1}	V _{AIN} = 5V to 19V (Note 5)	0.3	1.2	1.9	V
Feedback Voltage DC Accuracy	V _{FB1}	(Note 5)	--	5	--	%
Buck Switching Frequency	f _{BUCK}	F/W programmable, default 500 kHz (Note 5)	400	500	1200	kHz
Buck Maximum Duty Cycle	D _{BUCK}	(Note 5)	--	95	--	%
Driver Pull-Up On Resistance	R _{DRV}	(Note 5)	--	1	--	Ω
Power Path DC-DC Controller (Boost Mode)						
Feedback Reference Voltage	V _{FB2}	V _{AIN} = 5V to 19V (Note 5)	0.3	1.2	1.9	V
Feedback Voltage DC Accuracy	V _{FB2}	(Note 5)	--	5	--	%
Boost Switching Frequency	f _{BOOST}	F/W programmable, default 500 kHz (Note 5)	400	500	1200	kHz
Boost Maximum Duty Cycle	D _{BOOST}	(Note 5)	--	95	--	%
Power Path DC-DC Controller (PWM Mode)						
PWM Frequency Adjustment Range	f _{PWM}	Duty = 50% (Note 5)	110	--	300	kHz
PWM Duty Cycle Adjustment Range	D _{PWM}	(Note 5)	1	--	50	%
H-Bridge Power Inverter						
FET On Resistance	R _{ON}	Internal power inverter mode	--	0.1	--	Ω
FET On Resistance	R _{ON}	Gate drive mode for driving external power stage	--	1.2	--	Ω
Over-Current Protection Adjustment Range	I _{OC}	Resolution = 200mA (Note 5)	0.2	--	6	A
Over-Current Protection Accuracy	I _{OC}	(Note 5)	-40	--	40	%
PWM Frequency Adjustment Range	f _{PWM}	Duty = 50% (Note 5)	110	--	300	kHz
PWM Frequency Adjustment Resolution	f _{PWM}	(Note 5)	--	0.74	--	kHz
PWM Duty Cycle Adjustment Range	D _{PWM}	(Note 5)	1	--	50	%
PWM Phase Shift Adjustment Range	PH _{PWM}	(Note 5)	0	--	180	DEG

Parameter	Symbol	Test Conditions	Min	Typ	Max	Unit
COIL V/I Detection						
LVDET Input Voltage Range	LVDET		0	--	2	V
LCDET Input Voltage Range	LCDET	Buffer gain = 1 Buffer gain = 4	-0.9 -0.3	--	0.9 0.3	V
Operating Frequency Range	f		100	--	300	kHz
Over-Temperature Protection						
Thermal Shutdown Threshold	T _{J_SD}	Shut down power path when die temp reach threshold (Note 5)	--	125	--	°C
Hysteresis	T _{J_HYS}	F/W programmable (Note 5)	--	10	--	°C
Digital Input/Output (LSEL0, LSEL1, LSEL2, SSDAT, SSCLK, SMDAT, SMCLK, VD1P8, BUZZ, EN, UATX, UARX)						
Input Voltage	Low-Level	V _{IL}	0	--	0.5	V
	High-Level	V _{IH}	1.4	--	1.8	
Output Voltage	Low-Level	V _{OL}	0	--	0.2	V
	High-Level	V _{OH}	1.4	--	1.9	
Output High Source Current	I _{OH_MAX}	V _{OH} = VD1P8 - 0.2V	--	--	200	μA
Output Low Sink Current	I _{OL_MAX}	V _{OL} = 0.2V	--	--	200	μA

Note 1. Stresses beyond those listed “Absolute Maximum Ratings” may cause permanent damage to the device. These are stress ratings only, and functional operation of the device at these or any other conditions beyond those indicated in the operational sections of the specifications is not implied. Exposure to absolute maximum rating conditions may affect device reliability.

Note 2. θ_{JA} is measured under natural convection (still air) at T_A = 25°C with the component mounted on a high effective-thermal-conductivity four-layer test board on a JEDEC 51-7 thermal measurement standard.

Note 3. Devices are ESD sensitive. Handling precaution is recommended.

Note 4. The device is not guaranteed to function outside its operating conditions.

Note 5. Specification is guaranteed by design and/or correlation with statistical process control.

Typical Application Circuit

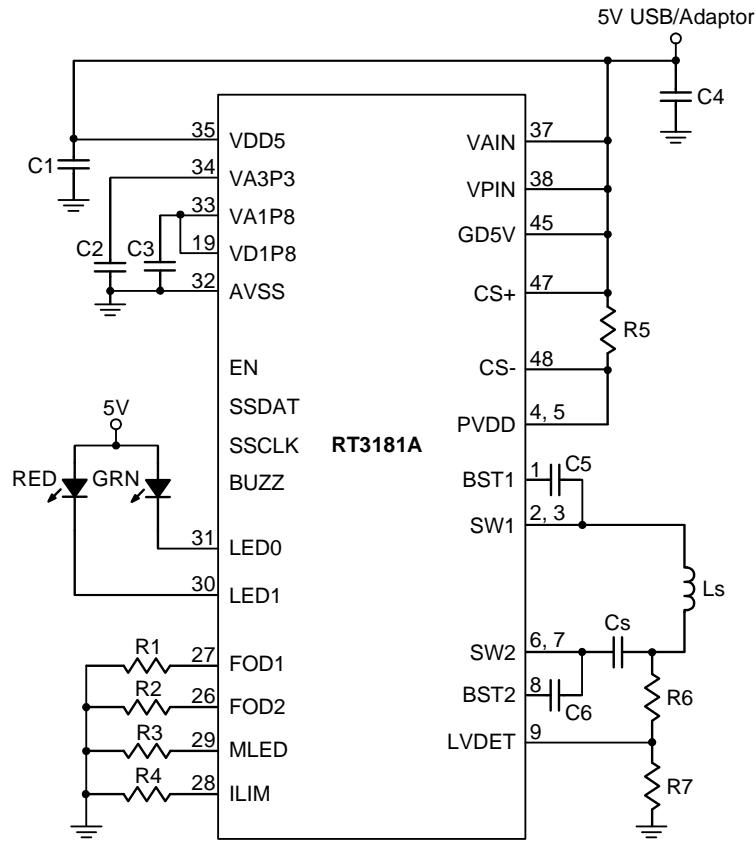

Figure 1. WPC LP A11 Minimized BOM Transmitter Application Circuit

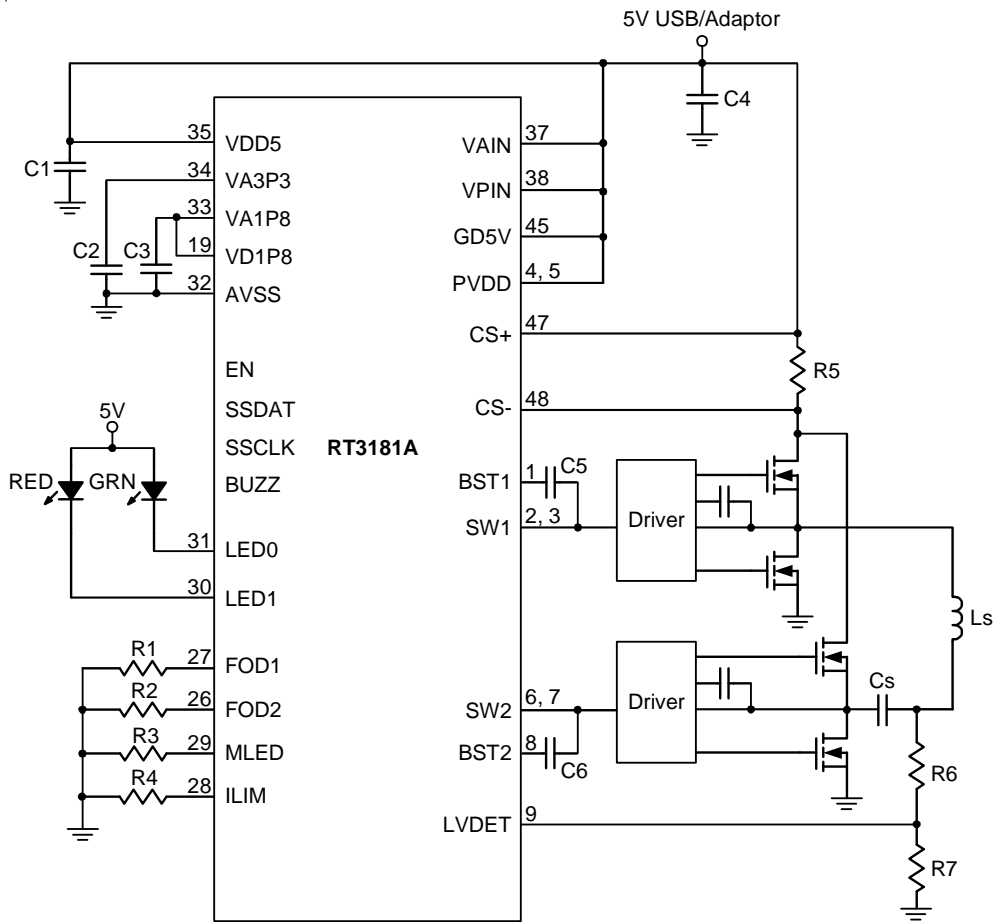

Figure 2. WPC LP A11 High Performance Transmitter Application Circuit

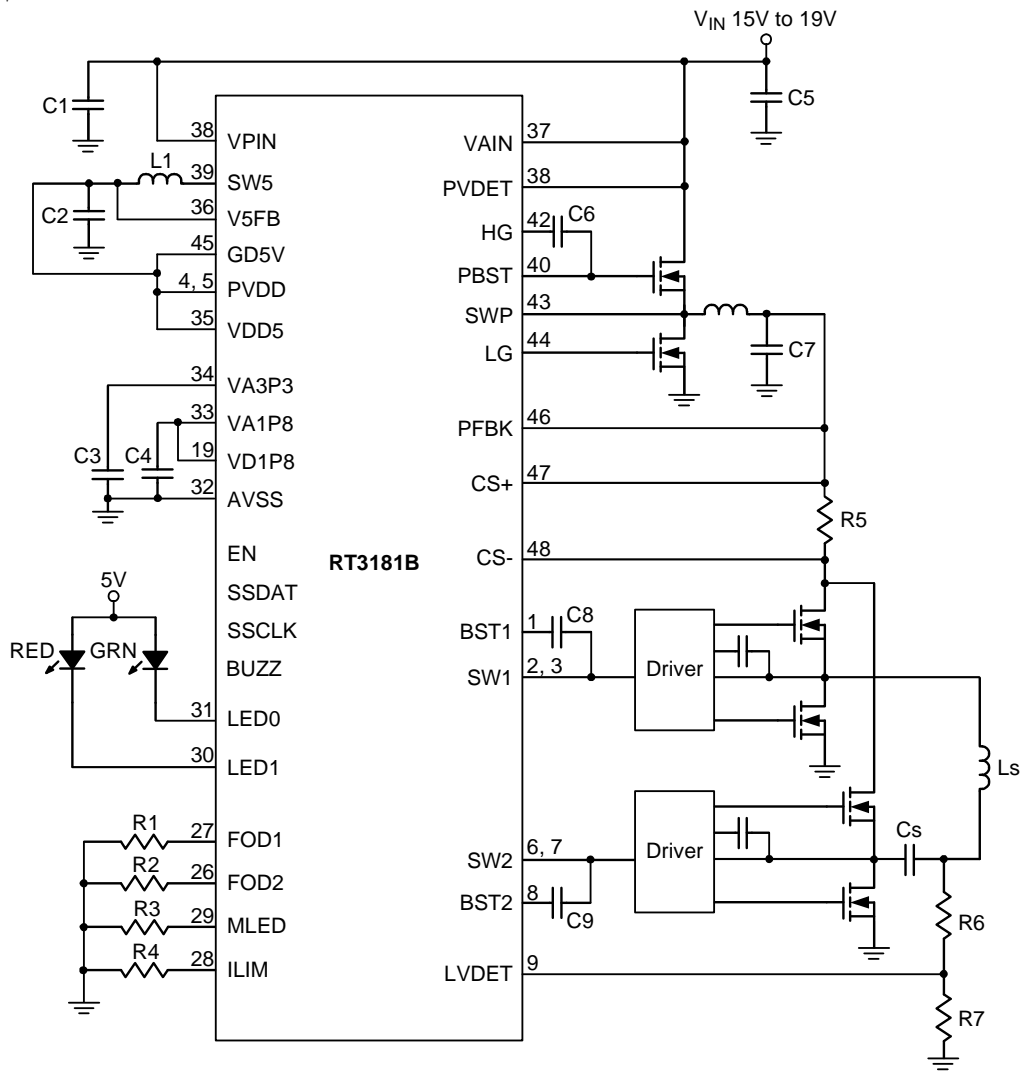

Figure 3. WPC MP-A5 Transmitter Application Circuit

Application Information

The RT3181A supports fully integrated design at low power 5W transmitter which is able to be powered from a USB or a 5V adapter power supply. Figure 1 shows a typical application circuit of WPC LP A11 design transmitter with minimized BOM. The RT3181A provides an internal H-Bridge Power Inverter to drive the power transmitting coil.

Figure 2 shows another application circuit of WPC LP A11 design transmitter for high performance applications. An external H-Bridge power inverter is adopted to drive the power transmitting coil.

The RT3181A is able to support WPC medium power 15W solution. A typical application circuit of WPC MP-A5 design transmitter for high performance applications shown as Figure 3. The RT3181A provides an internal DC-DC buck controller to convert input voltage to the required supply voltage for the H-Bridge Power Inverter to drive its power transmitting coil.

Current Sense

The RT3181A provides an internal amplifier for sensing the input current of power stage. Select a suitable current sense resistor and connect CS+ and CS- pins between the resistor.

Indicator

The RT3181A provides two open-drain output pins, LED0 and LED1, to indicate the status of the wireless power transmitter. The LED0/LED1 is programmable depending system design requirements.

The RT3181A also provides a BUZZ pin for sound notification. The BUZZ is programmable based on system design requirements.

I²C Interface

The RT3181A provides I²C interface for data communication. The I²C interface can be used to allow host control of the RT3181A. The host can control and monitor various operating conditions of the RT3181A. The I²C supports a programmable 7 bits device address up to 400kb/s.

External Thermal Management

The RT3181A provides an external device thermal management function with an external NTC thermistor connected between THERM pin and GND pin shown as Figure 4. The Thermistor Interface measures the resistance of an external NTC thermistor. It provides the thermistor voltage to the ADC for monitoring by the MCU and asserts the NTC_ALARM signal if the thermistor voltage exceeds a programmed threshold.

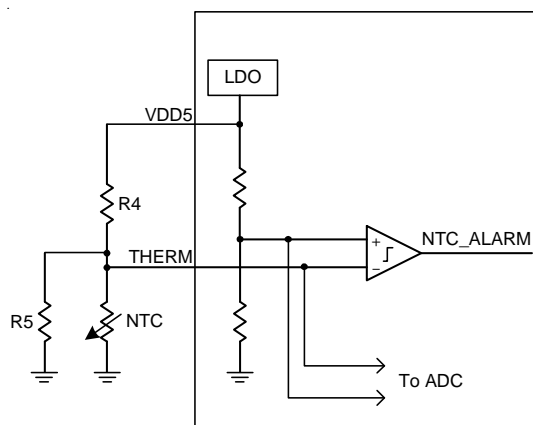

Figure 4. External Temperature Sense Circuit

Internal Over-Temperature Protection

The RT3181A provides an Over-Temperature Protection (OTP) feature to prevent excessive power dissipation from overheating the device. The OTP function shuts down the linear regulator operation when the junction temperature exceeds 125°C. Once the junction temperature cools down by around 10°C, the receiver will automatically resume operating.

Thermal Considerations

The junction temperature should never exceed the absolute maximum junction temperature $T_{J(MAX)}$, listed under Absolute Maximum Ratings, to avoid permanent damage to the device. The maximum allowable power dissipation depends on the thermal resistance of the IC package, the PCB layout, the rate of surrounding airflow, and the difference between the junction and ambient temperatures. The maximum power dissipation can be calculated using the following formula :

$$P_{D(MAX)} = (T_{J(MAX)} - T_A) / \theta_{JA}$$

where $T_{J(MAX)}$ is the maximum junction temperature, T_A is the ambient temperature, and θ_{JA} is the junction-to-ambient thermal resistance.

For continuous operation, the maximum operating junction temperature indicated under Recommended Operating Conditions is 125°C. The junction-to-ambient thermal resistance, θ_{JA} , is highly package dependent. For a WQFN-48L 6x6 package, the thermal resistance, θ_{JA} , is 26.8°C/W on a standard JEDEC 51-7 high effective-thermal-conductivity four-layer test board. The maximum power dissipation at $T_A = 25^\circ\text{C}$ can be calculated as below :

$$P_{D(MAX)} = (125^\circ\text{C} - 25^\circ\text{C}) / (26.8^\circ\text{C/W}) = 3.73\text{W for a WQFN-48L 6x6 package.}$$

The maximum power dissipation depends on the operating ambient temperature for the fixed $T_{J(MAX)}$ and the thermal resistance, θ_{JA} . The derating curves in Figure 5 allows the designer to see the effect of rising ambient temperature on the maximum power dissipation.

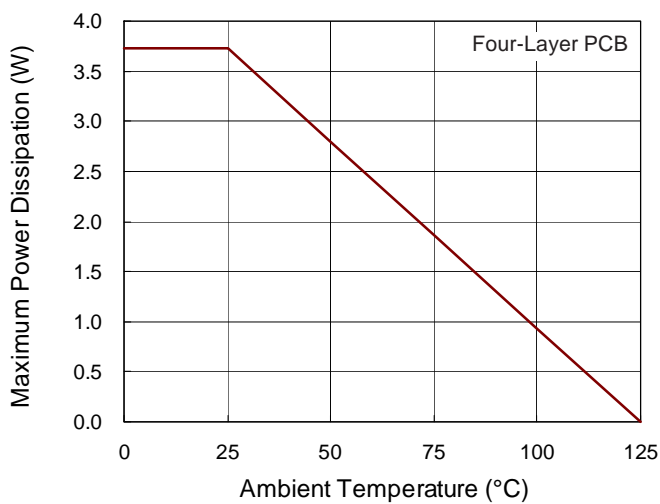

Figure 5. Derating Curve of Maximum Power Dissipation

Layout Considerations

Follow the PCB layout guidelines for optimal performance of the IC.

- ▶ Keep the traces of main current paths as short and wide as possible.
- ▶ Place the capacitors as close as possible to the IC.
- ▶ Power ground should be as large as possible and connected to a power plane for thermal dissipation.

For further design information, please contact Richtek.

Outline Dimension

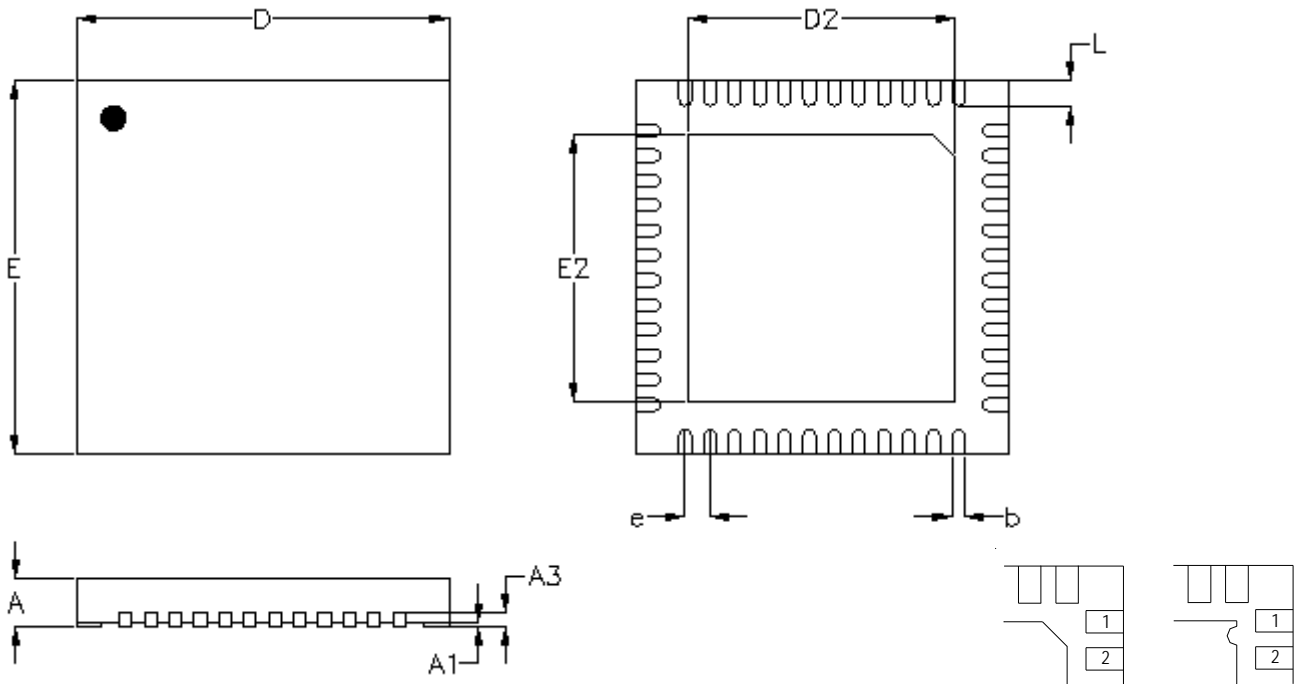

DETAIL A

Pin #1 ID and Tie Bar Mark Options

Note : The configuration of the Pin #1 identifier is optional, but must be located within the zone indicated.

Symbol	Dimensions In Millimeters		Dimensions In Inches		
	Min	Max	Min	Max.	
A	0.700	0.800	0.028	0.031	
A1	0.000	0.050	0.000	0.002	
A3	0.175	0.250	0.007	0.010	
b	0.150	0.250	0.006	0.010	
D	5.950	6.050	0.234	0.238	
D2	Option 1	4.250	4.350	0.167	0.171
	Option 2	4.350	4.450	0.171	0.175
E	5.950	6.050	0.234	0.238	
E2	Option 1	4.250	4.350	0.167	0.171
	Option 2	4.350	4.450	0.171	0.175
e	0.400		0.016		
L	0.350	0.450	0.014	0.018	

W-Type 48L QFN 6x6 Package