

## Dual Channel 10s2p WLED Drivers

### General Description

The RT4531 is a dual-channel current source with high-efficiency asynchronous boost converter for backlight application. The RT4531 has built-in 1.5A/36V power MOSFET and two high current-matching capability current sink, so RT4531 can drives up 10s2p white LED. The RT4531 can allow very low voltage headroom control, therefore to improve LED strings efficiency effectively.

The RT4531 supports both PWM dimming and 1-wire digital dimming interface and it can realize 10 bit brightness code programming.

The RT4531 provides complete protection functions such as input Under-Voltage Lockout (UVLO), Over-Current Protection (OCP), Output Over Voltage (OVP) and Over-Temperature Protection (OTP).

The RT4531 is available in the WL-CSP-9B 1.35x1.35 (BSC) package.

### Applications

- Smart Phones
- Probable Instruments
- Backlight for Small and Media Form
- Factor LCD Display with Single-cell Battery Input

### Features

- **Input Voltage Range : 2.5V to 5.5V**
- **Internal Soft-Start, UVLO, OTP, OCP, OVP**
- **Typical Shutdown Current : < 1 $\mu$ A**
- **1MHz Switching Frequency**
- **Drives Up to 10 WLEDs in Two Strings**
- **Independent PWM Dimming and 1-Wire Dimming Control**
- **PWM Dimming Frequency from 20k to 100kHz**
- **Up to 10 Bit Dimming Resolution**
- **LED Current Accuracy  $\pm 2\%$  ( $I_{FBx} = 20mA$ )**
- **LED Current Matching  $\pm 2\%$  ( $I_{FBx} = 20mA$ )**
- **Built-in IFB1/IFB2 pin OVP, Short Protection, and Un-Use Detection**

### Ordering Information

RT4531 □  
 Package Type  
 WSC : WL-CSP-9B 1.35x1.35 (BSC)

Note :

Richtek products are :

- ▶ RoHS compliant and compatible with the current requirements of IPC/JEDEC J-STD-020.
- ▶ Suitable for use in SnPb or Pb-free soldering processes.

### Simplified Application Circuit

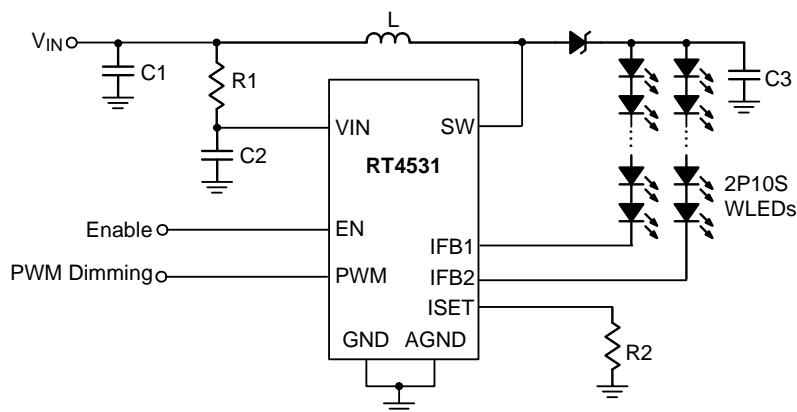

Pin Configurations

(TOP VIEW)

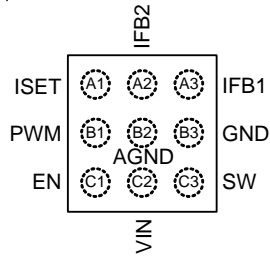

WL-CSP-9B 1.35x1.35 (BSC)

Marking Information

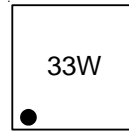

33 : Product Code

W : Date Code

Functional Pin Description

Pin No.	Pin Name	Pin Function
A1	ISET	Full-Scale LED Current Set Pin. Connecting a resistor to the pin programs the full-scale LED current.
A2	IFB2	Single Output 2 for Backlight LED.
A3	IFB1	Single Output 1 for Backlight LED.
B1	PWM	Enable Control, and PWM Dimming Signal Input.
B2	AGND	Analog Ground.
B3	GND	Power Ground.
C1	EN	Enable Control, and 1-Wire Dimming Signal Input.
C2	VIN	Supply Input Pin.
C3	SW	Switch Node of Boost Converter.

## Function Block Diagram

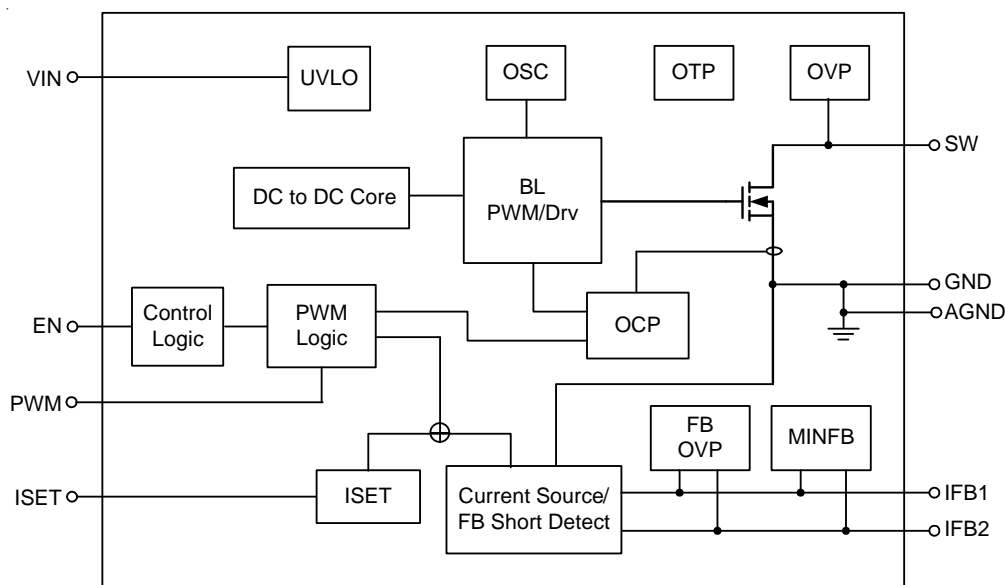

## Operation

The RT4531 is a high efficiency solution with 10S2P string for backlight applications. The RT4531 optimizes the feedback regulation voltage to provide high efficiency and also keep high current matching. The RT4531 can receive either the 1-wire dimming at EN pin or PWM dimming at PWM pin for brightness dimming. If the 1-wire dimming is selected, the PWM pin should be kept high; If the PWM dimming is selected, the EN pin should be kept high.

### OCP Protection

The RT4531 features a 1.5A OCP. The driver provides cycle-by-cycle current limit function to control the current on power switch. The boost switch turns off when the inductor current reaches this current threshold and it remains off until the beginning of the next switching cycle. This protects the RT4531 and external component under overload conditions.

### OTP Protection

The OTP function will disable boost and current source when the junction temperature exceeds 150°C. Then restart to soft-start when the junction temperature is smaller than 135°C.

### OVP Protection

The OVP function monitors the SW pin's voltage. Once it exceeds OVP threshold = 36.5V twice, the boost and current source will be latched off. Until PWM or EN go high from low again, the latch state will be released.

### 1-wire Brightness Dimming

The RT4531 is built-in a 10-bit resolution brightness control. The EN pin features a simple 1-wire interface to allow digital brightness control. If the 1-wire dimming is needed, signals of a specific pattern should be input detection window into EN pin; Otherwise, PWM pin need to be enabled.(refer to Timing Diagram1 for Continuous Coding).The Register Program and register map give an overview of the protocol used by RT4531.

### PWM Brightness Dimming

Besides programmable built-in 1-wire backlight LED current control, the RT4531 features a built-in PWM dimming current control by PWM pin, offering a linear current dimming by external clock source. In order to guarantee the PWM dimming resolution, recommending PWM dimming frequency have to be operated at range of 20kHz to 100kHz.

## Absolute Maximum Ratings (Note 1)

- Supply Voltage,  $V_{IN}$  ----- -0.3V to 6V
- LED Switching Voltage, SW ----- 38V
- LED Current Source Voltage, IFB1, IFB2 ----- -0.3V to 6V
- Digital Clock Control Pin, EN, PWM ----- -0.3V to 6V
- Other Pins, ISET ----- -0.3V to 6V
- Power Dissipation,  $P_D$  @  $T_A = 25^\circ\text{C}$   
 WL-CSP-9B 1.35x1.35 (BSC) ----- 1.22W
- Package Thermal Resistance (Note 2)  
 WL-CSP-9B 1.35x1.35 (BSC),  $\theta_{JA}$  ----- 81.5°C/W
- Junction Temperature ----- 150°C
- Lead Temperature (Soldering, 10 sec.) ----- 260°C
- Storage Temperature Range ----- -65°C to 150°C
- ESD Susceptibility (Note 3)  
 HBM (Human Body Model) ----- 2kV  
 MM (Machine Model) ----- 200V

## Recommended Operating Conditions (Note 4)

- Supply Input Voltage,  $V_{IN}$  ----- 2.5V to 5.5V
- Junction Temperature Range ----- -40°C to 125°C
- Ambient Temperature Range ----- -40°C to 85°C

## Electrical Characteristics

( $V_{IN} = 3.6\text{V}$ ,  $C_{IN} = 2.2\mu\text{F}$ ,  $C_{OUT} = 1\mu\text{F}$ ,  $L = 4.7\mu\text{H}$ ,  $T_A = 25^\circ\text{C}$ , unless otherwise specified)

Parameter	Symbol	Test Conditions	Min	Typ	Max	Unit
<b>Power Supply</b>						
UVLO	$V_{UVLO}$	$V_{IN}$ falls	--	2.2	2.3	V
UVLO Hysteresis Voltage	$\Delta V_{UVLO}$	$V_{IN}$ rises after UVLO	30	50	200	mV
$V_{IN}$ Supply Current	$I_Q$	EN = High, Non-switching	--	1.2	--	mA
$V_{IN}$ Shutdown Current	$I_{SHDN}$	$V_{IN} = 5\text{V}$	--	1	--	$\mu\text{A}$
Thermal Shutdown	$T_{SD}$		--	150	--	$^\circ\text{C}$
Thermal Shutdown Hysteresis			--	15	--	$^\circ\text{C}$
<b>Back Light LED</b>						
Accuracy of Back Light Output Current 1/2	AIBL1, 2	$I_{FBx} = 20\text{mA}$	-2	--	2	%
Matching of Output Current	MIBL	$I_{FBx} = 20\text{mA}$	--	1	2	%
		$I_{FBx} = 500\mu\text{A}$	--	1	--	%
BLED Sense Voltage 1/2	VDSBL	$I_{FBx} = 20\text{mA}$ , measured on IFBx pin which has a lower voltage.	200	300	430	mV
Back Light Switching Frequency	$f_{blosc}$		0.88	1	1.12	MHz

Parameter	Symbol	Test Conditions	Min	Typ	Max	Unit
Maximum Duty Cycle	D <sub>MAX</sub>		90	95	--	%
Back Light N-MOSFET Ron	R <sub>DS(ON)_BLN</sub>		100	270	400	mΩ
Back Light Current Limit	I <sub>LIM_BL</sub>	After 5ms in soft-start	1.15	1.5	1.85	A
Back Light Over Voltage Protection	V <sub>BLOVP</sub>	Close loop, V <sub>IN</sub> = 3.6V	35.5	36.5	37.5	V
IFBx Pin Over Voltage Threshold	V <sub>IFBXOVP</sub>	Measure on IFBx pin	--	5	--	V
<b>Logic Control</b>						
One Wire Detection Delay	tes_delay	Measure from En low to high	300	--	--	μs
One Wire Detection Time	tes_det	En pin low time in detection window	400	--	--	μs
One Wire Detection Window	tes_win	Measure from En low to high, F <sub>blosc</sub> = 1MHz	--	1	--	ms
Start Time of Program Stream	t <sub>start</sub>		3	--	--	μs
End Time of Program Stream	t <sub>EOS</sub>		3	--	--	μs
High Time Low Bit	t <sub>H_LB</sub>	Logic 0	2	--	180	μs
Low Time Low Bit	t <sub>L_LB</sub>	Logic 0	2 x t <sub>H_LB</sub>	--	360	μs
High Time High Bit	t <sub>H_HB</sub>	Logic 1	2 x t <sub>L_HB</sub>	--	360	μs
Low Time High Bit	t <sub>L_HB</sub>	Logic 1	2	--	180	μs
EN Input Voltage	Logic-Low	V <sub>EN_L</sub>	--	--	0.4	V
	Logic-High	V <sub>EN_H</sub>	1.4	--	--	
PWM Input Voltage	Logic-Low	V <sub>PWM_L</sub>	--	--	0.4	V
	Logic-High	V <sub>PWM_H</sub>	1.4	--	--	
EN Pull Low Resistor	R <sub>EN</sub>		280	400	520	kΩ
PWM Pull Low Resistor	R <sub>PWM</sub>		280	400	520	kΩ
PWM Logic Low Width to Shutdown	T <sub>SD_PWM</sub>	PWM pin high to low, then shutdown	20	--	--	ms
EN Logic Low Width to Shutdown	T <sub>DS_EN</sub>	EN pin high to low, then shutdown	2.5	--	--	ms

**Note 1.** Stresses beyond those listed “Absolute Maximum Ratings” may cause permanent damage to the device. These are stress ratings only, and functional operation of the device at these or any other conditions beyond those indicated in the operational sections of the specifications is not implied. Exposure to absolute maximum rating conditions may affect device reliability.

**Note 2.** θ<sub>JA</sub> is measured at T<sub>A</sub> = 25°C on a high effective thermal conductivity four-layer test board per JEDEC 51-7.

**Note 3.** Devices are ESD sensitive. Handling precaution is recommended.

**Note 4.** The device is not guaranteed to function outside its operating conditions.

Typical Application Circuit

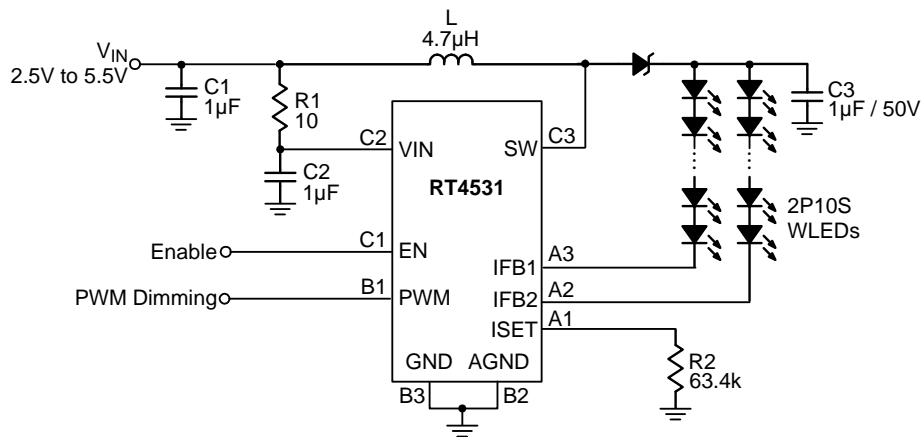

Timing Diagram

Timing Diagram1 for 1-wire Continuous Coding

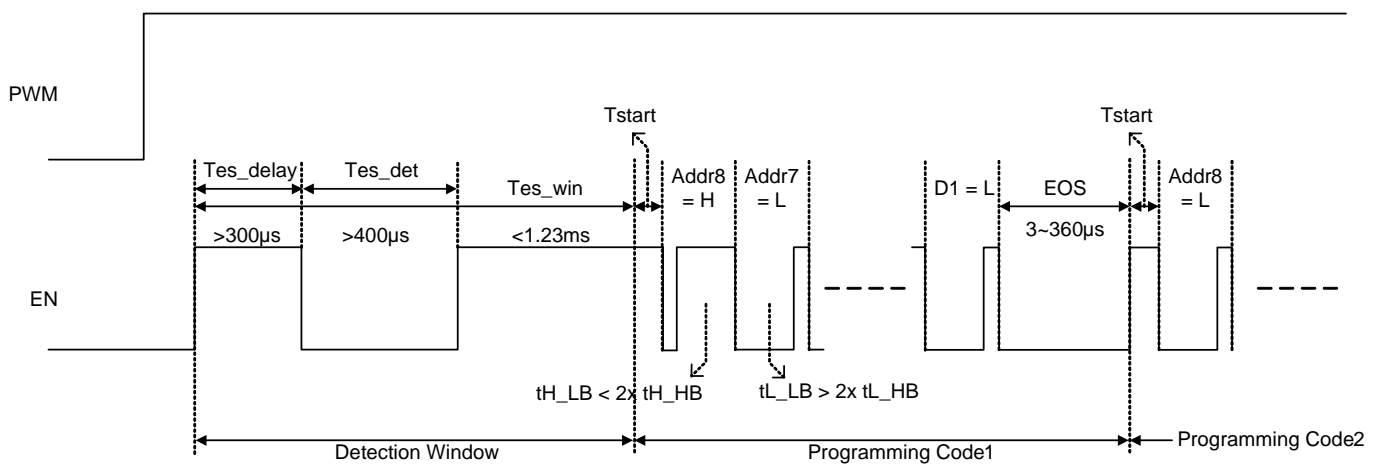

Timing Diagram2 for Shutdown and then Reprogram

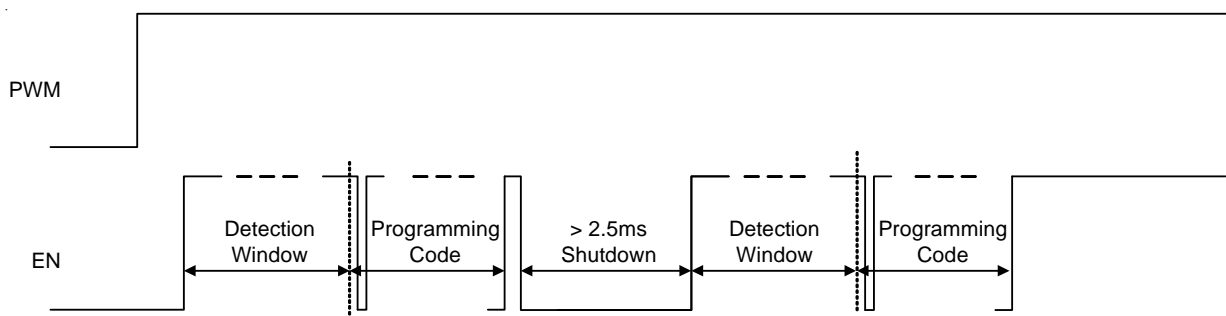

**Typical Operating Characteristics**

**Efficiency vs. Output Current**

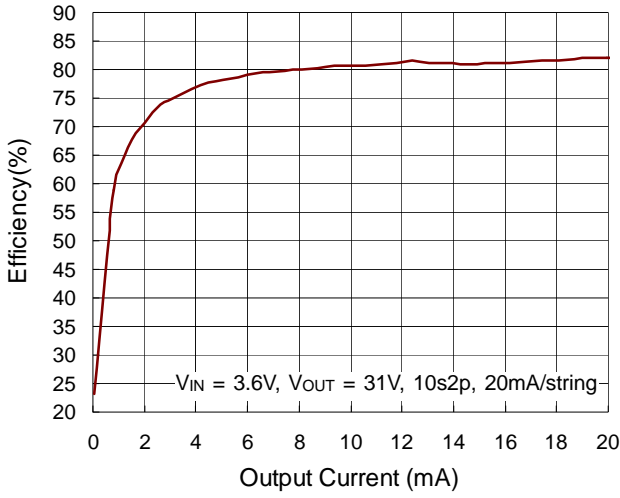

**Efficiency vs. Input Voltage**

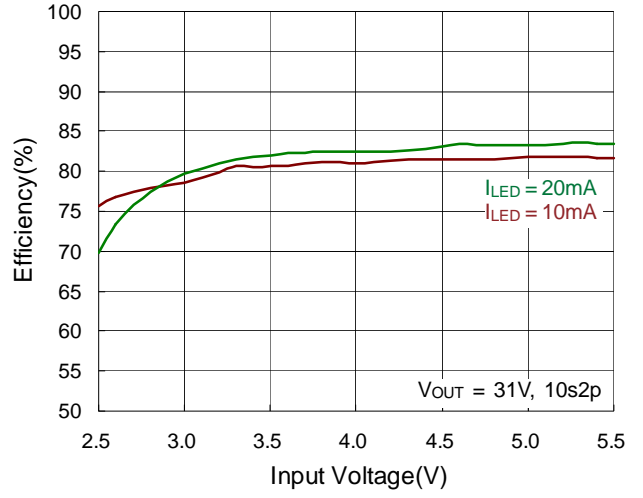

**Dimming Linearity**

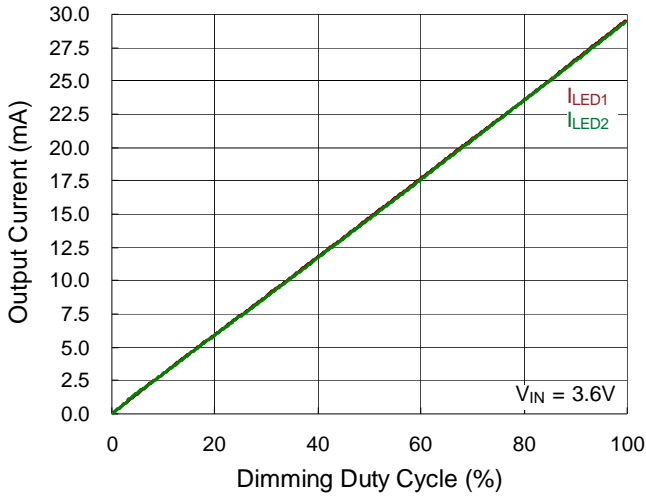

**Switching Frequency vs. Input Voltage**

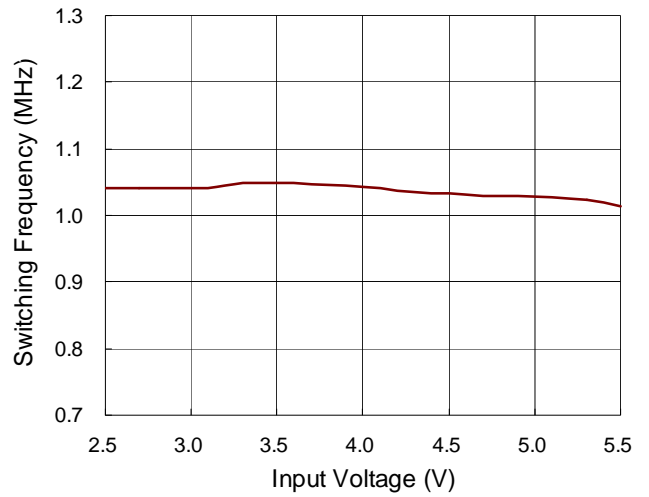

**Switching Frequency vs. Temperature**

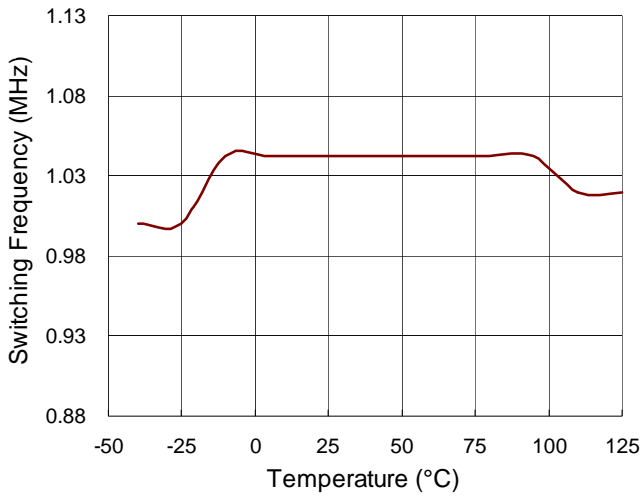

**Sense Voltage vs. Output Current**

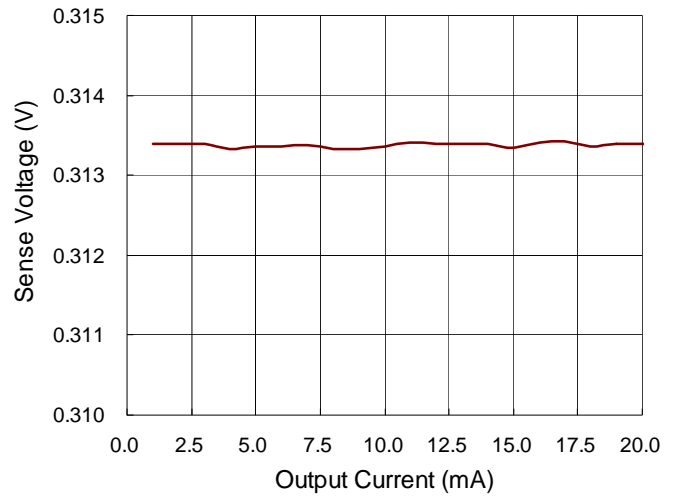

## Application Information

### Register Program

#### 1-Wire Interface (Device Address 0x2F)

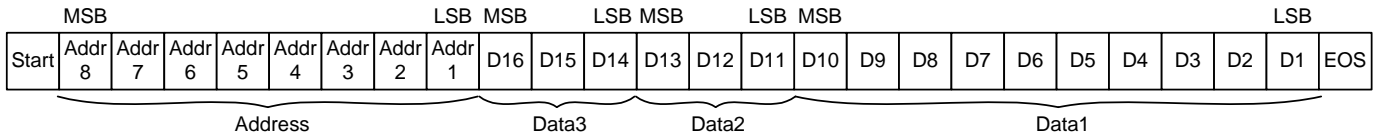

### Register Map

Bit	Label	Reset	Description
D16	Ramp Up<2>	0	[000] = 4μs, [001] = 8μs, [010] = 16μs, [011] = 64μs, [100] = 256μs, [101] = 1.024ms, [110] = 2.048ms, [111] = 4.096ms
D15	Ramp Up<1>	0	
D14	Ramp Up<0>	1	
D13	Ramp Down<2>	0	[000] = 4μs, [001] = 8μs, [010] = 16μs, [011] = 64μs, [100] = 256μs, [101] = 1.024ms, [110] = 2.048ms, [111] = 4.096ms
D12	Ramp Down<1>	0	
D11	Ramp Down<0>	1	
D10	ILED<9>	0	MSB = sDAC<9>
D9	ILED<8>	0	sDAC<8>
D8	ILED<7>	0	sDAC<7>
D7	ILED<6>	0	sDAC<6>
D6	ILED<5>	0	sDAC<5>
D5	ILED<4>	0	sDAC<4>
D4	ILED<3>	0	sDAC<3>
D3	ILED<2>	0	sDAC<2>
D2	ILED<1>	0	sDAC<1>
D1	ILED<0>	0	LSB = sDAC<0>



**Protection Actions**

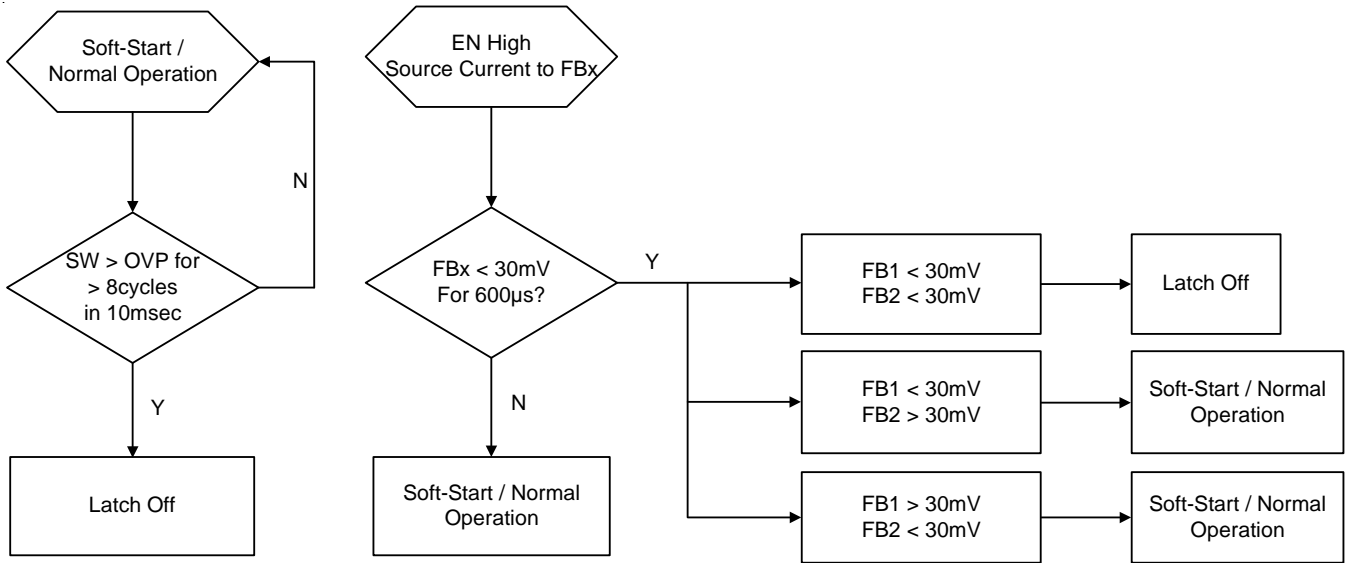

## LED Current Setting

The dual channels of the RT4531 can provide up to 30mA current each.

No matter either 1-wire Brightness Dimming or PWM Brightness Dimming is selected, the full-scale current (current when dimming duty cycle is 100%) of each channel should be programmed by an external resistor R<sub>ISET</sub> at ISET pin according to Equation 1.

$$I_{FB} = \frac{V_{ISET}}{R_{ISET}} \times K_{ISET} \quad (1)$$

Where :

$$V_{ISET} = 1V,$$

$$K_{ISET} = 1268$$

## Brightness Control

### a. 1-wire Brightness Dimming

The RT4531 is built-in a 10-bit resolution brightness control. The EN pin features a simple 1-wire interface to allow digital brightness control. If the 1-wire dimming is needed, signals of a specific pattern should be input detection window into EN pin; Otherwise, PWM pin need to be enabled.(refer to Timing Diagram1 for Continuous Coding).The Register Program and register map give an overview of the protocol used by RT4531.By the 1-wire Brightness Dimming, a master can program the 10-bit code D1(LSB) to D10(MSB) to any of 1024 steps with a single command. The programmed value will be stored in an internal register and set the dual-channel current according to Equation 2. The code will be reset to default value when the IC is shut down or disabled.

$$I_{FBX} = I_{FB} \times \frac{\text{DAC code}}{1024} \quad (2)$$

Where :

I<sub>FB</sub> : the full-scale LED current set by the R<sub>ISET</sub> at ISET pin.

Code : the 10-bit DAC code D1~D10 programmed by 1-wire interface.

To enter 1-wire dimming mode, the following digital pattern on the EN pin must be recognized by the IC when the IC starts from the shutdown mode.

1. Pull the EN pin high to enable the RT4531 and start the detection window for digital dimming.
2. After the digital dimming detection delay time (T<sub>es\_delay</sub>, >300μs), drive the EN low for more than the detection time (T<sub>es\_det</sub>, >400μs).
3. Pull the EN pin high after the detection time (>400μs) and before the detection window (T<sub>es\_win</sub>, <1.23ms), once the above 3 conditions are met, the IC immediately enters the 1-wire dimming mode. The digital dimming communication can start before the detection window expires. Once the dimming mode is selected, it cannot be changed without another start up. This means the IC needs to be shut down by pulling the EN low for 2.5ms and restarts. See the dimming mode detection and soft-start for a graphical explanation. (see Timing Diagram1 for 1-wire Continuous Coding).

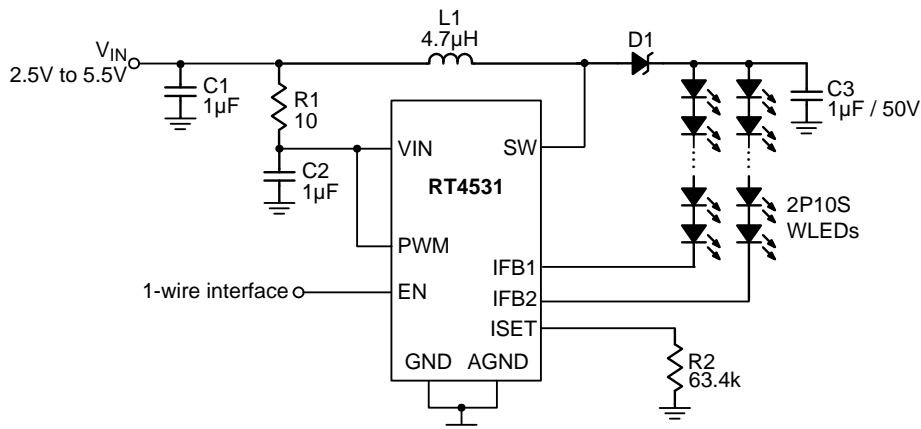

Figure 1. RT4531 1-wire Dimming Typical Application

**b. PWM Brightness Dimming**

Besides programmable built-in 1-wire backlight LED current control, the RT4531 features a built-in PWM dimming current control by PWM pin, offering a linear current dimming by external clock source. In order to guarantee the PWM dimming resolution, recommending PWM dimming frequency have to be operated at range of 20kHz to 100kHz. The PWM mode ramp time is 64μs each step.

When the PWM pin is constantly high, the dual channel current is regulated to full-scale according to Equation 1.

The PWM pin allows PWM signals to reduce this regulation current according to the PWM duty cycle; therefore,

it achieves LED brightness dimming. The relationship between the PWM duty cycle and  $I_{FBx}$  current is given by Equation 3.

$$I_{FBX} = I_{FB} \times \text{Duty}(\%) \tag{3}$$

Where :

$I_{FBX}$  is the current of each current sink,  $I_{FB}$  is the full-scale LED current, Duty is the duty cycle information detected from the PWM signals.

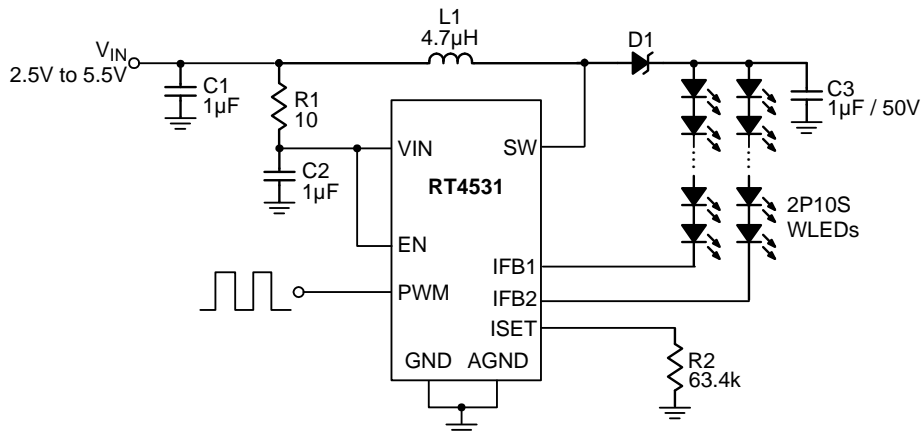

Figure 2. RT4531 PWM Dimming Typical Application

**OCP Protection**

The RT4531 features a 1.5A OCP. The driver provides cycle-by-cycle current limit function to control the current on power switch. The boost switch turns off when the inductor current reaches this current threshold and it remains off until the beginning of the next switching cycle. This protects the RT4531 and external component under overload conditions.

**OTP Protection**

The OTP function will disable boost and current source when the junction temperature exceeds 150°C. Then restart to soft-start when the junction temperature is smaller than 135°C.

**Open LED Protection**

Open LED protection circuitry prevents IC damage as the result of LED disconnection. The RT4531 monitors the voltage at the LX pin during each switching cycle. The circuitry turns off the switch and shuts down the IC as soon as the LX voltage exceeds the VOVP threshold. The device remains in shutdown mode until it is enabled by toggling the EN pin logic. The RT4531 is designed to work with inductor values for 4.7μH (Taiyo NR4018T4R7M) and Cout values for 1μF/50V (Murata 0603/X5R) that the OVP is 37.5V typ. Generally, the VF of the backlight LED is about 3.1 to 3.3V, the RT4531 can support up to 10 LEDs and it would not be trigger OVP.

### Thermal Considerations

For continuous operation, do not exceed absolute maximum operation junction temperature. The maximum power dissipation depends on the thermal resistance of IC package, PCB layout, the rate of surroundings airflow and temperature difference between junction to ambient. The maximum power dissipation can be calculated by following formula :

$$P_{D(MAX)} = (T_{J(MAX)} - T_A) / \theta_{JA}$$

Where  $T_{J(MAX)}$  is the maximum operation junction temperature,  $T_A$  is the ambient temperature and the  $\theta_{JA}$  is the junction to ambient thermal resistance.

For recommended operating condition specifications, the maximum junction temperature is 125°C. The junction to ambient thermal resistance,  $\theta_{JA}$ , is layout dependent. For WL-CSP-9B 1.35x1.35 (BSC) package, the thermal resistance,  $\theta_{JA}$ , is 81.5°C/W on the standard JEDEC 51-7 four-layer thermal test board. The maximum power dissipation at  $T_A = 25^\circ\text{C}$  can be calculated by following formula :

$$P_{D(MAX)} = (125^\circ\text{C} - 25^\circ\text{C}) / (81.5^\circ\text{C/W}) = 1.22\text{W for WL-CSP-9B 1.35x1.35 (BSC) package}$$

The maximum power dissipation depends on operating ambient temperature for fixed  $T_{J(MAX)}$  and thermal resistance  $\theta_{JA}$ . The derating curve in Figure 3 of derating curves allows the designer to see the effect of rising ambient temperature on the maximum power allowed.

### Layout Consideration

For best performance of the RT4531, the following guidelines must be strictly followed.

- ▶ Input and Output capacitors should be placed close to the IC and connected to ground plane to reduce noise coupling.
- ▶ The GND and Exposed Pad should be connected to a strong ground plane for heat sinking and noise protection.
- ▶ Keep the main current traces as possible as short and wide.
- ▶ SW node of DC/DC converter is with high frequency voltage swing. It should be kept at a small area.
- ▶ It recommended to separate the ISET line and PWM line that avoid the PWM signal couple to ISET.

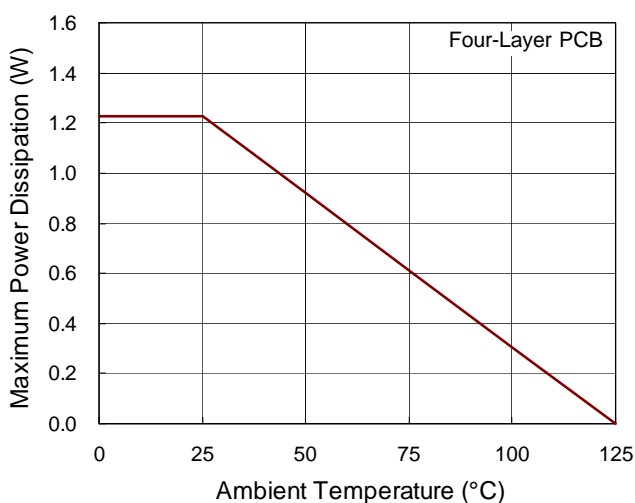

Figure 3. Derating Curve of Maximum Power Dissipation

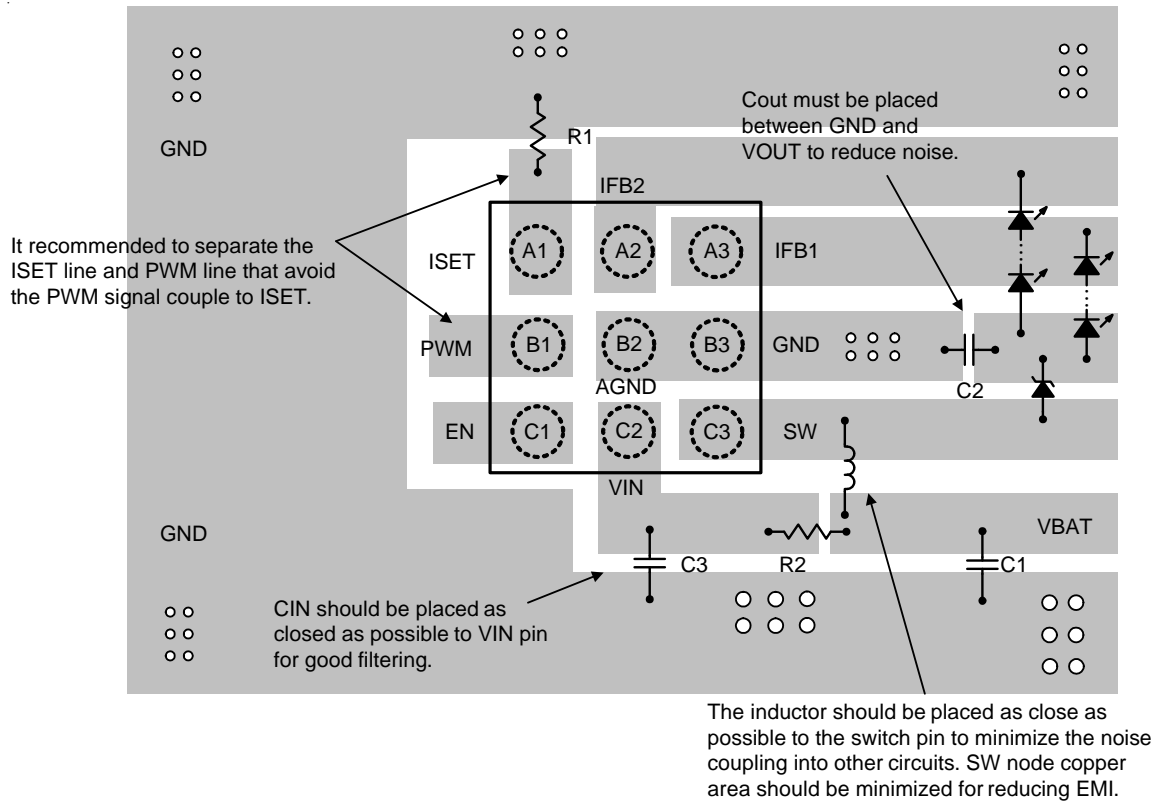

Figure 4. PCB Layout Guide

Table 1. Recommended Components for Typical Application Circuit

Reference	Part Number	Description	Manufacture
Schottky Diode	SS0540	Schottky Diode	PANJIT
C1	EMK107BJ105MA-T	Capacitor, Ceramic, 1 $\mu$ F/16V X5R	Taiyo Yuden
R1	RC0603FR-0763K4	Resistor 63.4k $\Omega$ , 1%	YAGEO
C2	GRM188R61H105KAAL	MLCC,0603,X5R,50V,1 $\mu$ F	Murata
L	NR4018T4R7M	Inductor, 4.7 $\mu$ H	Taiyo Yuden
C3	EMK107BJ105MA-T	Capacitor, Ceramic, 1 $\mu$ F/16V X5R	Taiyo Yuden
R2	RC0603FR-0710R	Resistor 10 $\Omega$ , 1%	YAGEO