

## 3A, 2MHz, Synchronous Step-Down Converter

### General Description

The RT8065 is a simple, easy-to-use current mode controlled 3A synchronous step-down DC-DC converter with an input supply voltage range from 2.7V to 5.5V. The device built-in an accurate 0.8V reference voltage and integrates low  $R_{DS(ON)}$  power MOSFETs to achieve high efficiency in both WDFN-8L 3x3 and SOP-8 (Exposed Pad) packages.

The RT8065 operates in automatic PSM that maintains high efficiency during light load operation. The device features cycle-by-cycle current-limit protection to prevent the device from the catastrophic damage in output short circuit, over-current or inductor saturation. Adjustable soft-start function prevents inrush current during start-up. The device also features input under-voltage lockout, output under-voltage protection, and over-temperature protection to provide safe and smooth operation in all operating conditions.

### Ordering Information

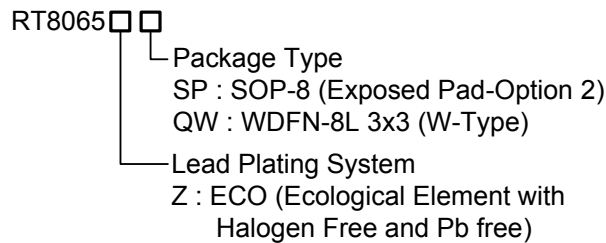

Note :

Richtek products are :

- ▶ RoHS compliant and compatible with the current requirements of IPC/JEDEC J-STD-020.
- ▶ Suitable for use in SnPb or Pb-free soldering processes.

### Features

- Input Voltage Range from 2.7V to 5.5V
- Integrated 120mΩ and 80mΩ FETs
- 100% Duty Cycle for Lowest Dropout
- Power Saving Mode for Light Loads
- Adjustable Frequency : 200kHz to 2MHz
- 0.8V Reference Allows Low Output Voltage
- Enable Function
- External Soft-Start
- Power Good Function
- Input Under-Voltage Lockout Protection
- Output Under-Voltage Protection
- Over-Temperature Protection
- RoHS Compliant and Halogen Free

### Applications

- LCD TVs and Monitors
- Notebook Computers
- Distributed Power Systems
- IP Phones
- Digital Cameras

### Marking Information

RT8065ZSP

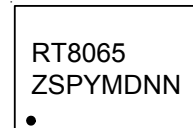

RT8065ZSP : Product Number

YMDNN : Date Code

RT8065ZQW

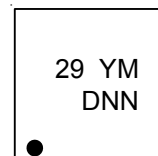

29 : Product Code

YMDNN : Date Code

## Pin Configuration

(TOP VIEW)

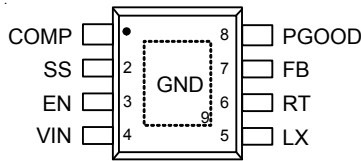

SOP-8 (Exposed Pad)

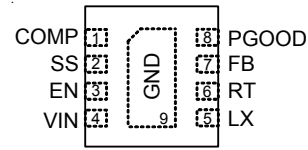

WDFN-8L 3x3

## Typical Application Circuit

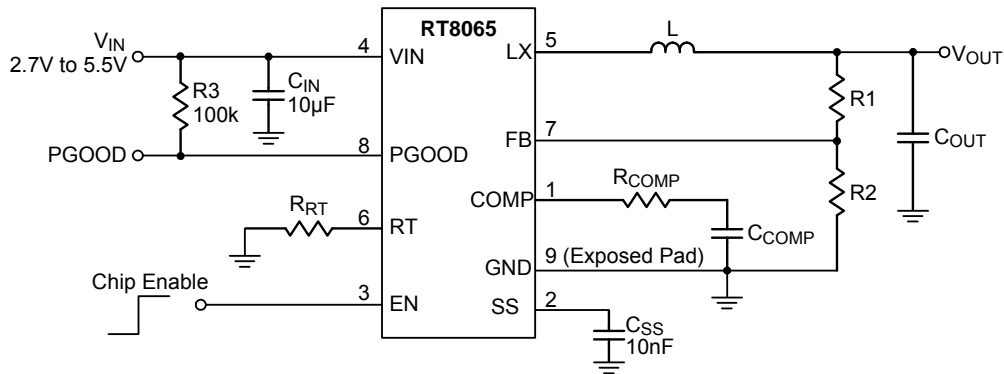

Table 1. Recommended Components Selection for  $f_{sw} = 1\text{MHz}$

$V_{OUT}$ (V)	$R_1$ (k $\Omega$ )	$R_2$ (k $\Omega$ )	$R_{COMP}$ (k $\Omega$ )	$C_{COMP}$ (pF)	$L$ ( $\mu\text{H}$ )	$C_{OUT}$ ( $\mu\text{F}$ )
3.3	75	24	33	560	2	22
2.5	51	24	22	560	2	22
1.8	30	24	15	560	1.5	22
1.5	21	24	13	560	1.5	22
1.2	12	24	11	560	1.5	22
1	6	24	8.2	560	1.5	22

Note:

Considering the effective capacitance de-rated with biased voltage level and size, the  $C_{OUT}$  component needs satisfy the effective capacitance at least  $15\mu\text{F}$  or above at targeted output level for stable and normal operation.

**Functional Pin Description**

Pin No.		Pin Name	Pin Function
SOP-8 (Exposed Pad)	WDFN-8L 3x3		
1	1	COMP	Compensation node. Connect external compensation elements to this pin to stabilize the control loop.
2	2	SS	Soft-start capacitor connection node. Connect an external capacitor between this pin and ground to set the soft-start time.
3	3	EN	Enable control input. Connect this pin to logic high enables the device and connect this pin to ground disables the device.
4	4	VIN	Power input. Connect input capacitors between this pin and PGND. It is recommended to use a 10 $\mu$ F, X5R, 0805 and a 0.1 $\mu$ F, X5R capacitors.
5	5	LX	Switch node between the internal switch and the synchronous rectifier. Connect this pin to the inductor.
6	6	RT	Oscillator Resistor Input. Connect a resistor from this pin to GND sets the switching frequency.
7	7	FB	Feedback voltage input. Connect this pin to the midpoint of the external feedback resistive divider to set the output voltage of the converter to the desired regulation level. The device regulates the FB voltage at a feedback reference voltage, typically 0.8V.
8	8	PGOOD	Power Good Indicator. This pin is an open drain logic output that is pulled to ground when the output voltage is not within $\pm 12.5\%$ of regulation point.
9 (Exposed Pad)	9 (Exposed Pad)	GND	GND exposed pad. The exposed pad is internally connected with GND and must be soldered to a large GND plane. Connect this GND plane to other layers with thermal vias to help dissipate heat from the device.

## Functional Block Diagram

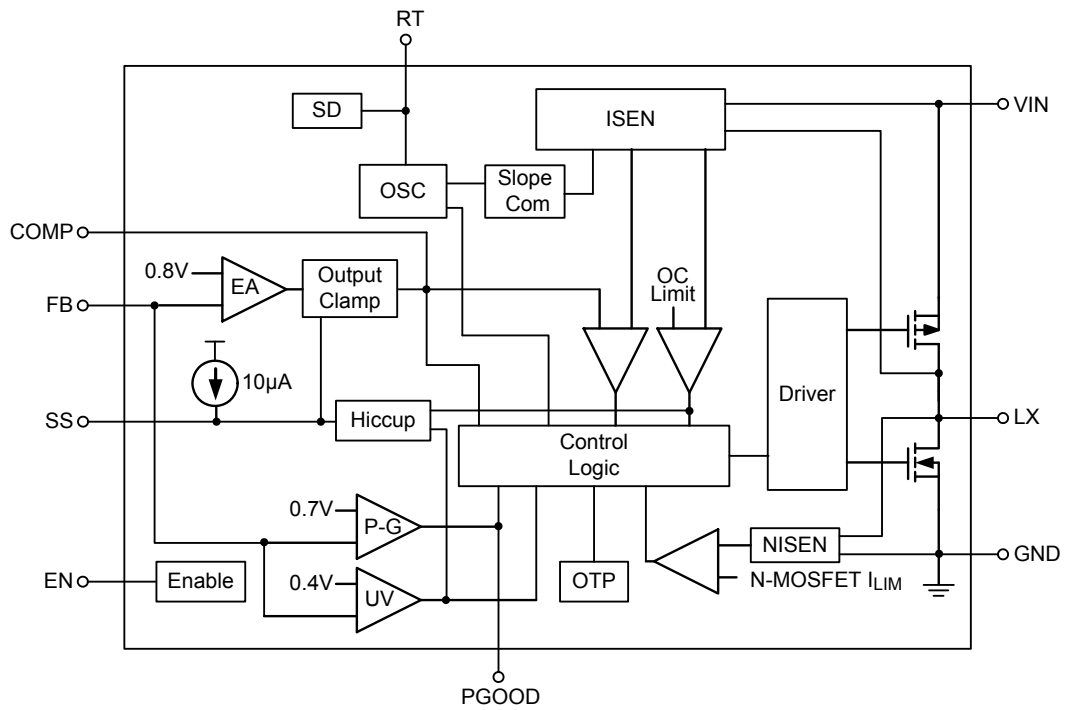

**Absolute Maximum Ratings** (Note 1)

- Supply Input Voltage,  $V_{IN}$  ----- -0.3V to 6V
- LX Pin Switch Voltage ----- -0.3V to 6V
- <10ns ----- -2.5V to 8.5V
- Other I/O Pin Voltages ----- -0.3V to 6V
- Power Dissipation,  $P_D$  @  $T_A = 25^\circ\text{C}$
- SOP-8 (Exposed Pad) ----- 1.333W
- WDFN-8L 3x3 ----- 1.429W
- Package Thermal Resistance (Note 2)
- SOP-8 (Exposed Pad),  $\theta_{JA}$  -----  $75^\circ\text{C/W}$
- SOP-8 (Exposed Pad),  $\theta_{JC}$  -----  $15^\circ\text{C/W}$
- WDFN-8L 3x3,  $\theta_{JA}$  -----  $70^\circ\text{C/W}$
- WDFN-8L 3x3,  $\theta_{JC}$  -----  $8.2^\circ\text{C/W}$
- Junction Temperature -----  $150^\circ\text{C}$
- Lead Temperature (Soldering, 10 sec.) -----  $260^\circ\text{C}$
- Storage Temperature Range -----  $-65^\circ\text{C}$  to  $150^\circ\text{C}$
- ESD Susceptibility (Note 3)
- HBM (Human Body Model) ----- 2kV

**Recommended Operating Conditions** (Note 4)

- Supply Input Voltage,  $V_{IN}$  ----- 2.7V to 5.5V
- Junction Temperature Range -----  $-40^\circ\text{C}$  to  $125^\circ\text{C}$
- Ambient Temperature Range -----  $-40^\circ\text{C}$  to  $85^\circ\text{C}$

**Electrical Characteristics**

( $V_{IN} = 3.3\text{V}$ ,  $T_A = 25^\circ\text{C}$ , unless otherwise specified)

Parameter	Symbol	Test Conditions	Min	Typ	Max	Unit	
VIN Supply Input Operating Voltage	$V_{IN}$		2.7	--	5.5	V	
Feedback Reference Voltage	$V_{REF}$		0.784	0.8	0.816	V	
Supply Current (Quiescent)	$I_Q$	$V_{EN} = 2\text{V}$ , $V_{FB} = 0.78\text{V}$ , Not Switching	--	460	--	$\mu\text{A}$	
Supply Current (Shutdown)	$I_{SHDN}$	$V_{EN} = 0\text{V}$	--	--	10		
Error Amplifier Trans-conductance	gm		--	400	--	$\mu\text{A/V}$	
Current Sense Trans-resistance	$R_T$		--	0.3	--	$\Omega$	
Switching Frequency		$R_{RT} = 330\text{k}\Omega$	0.8	1	1.2	MHz	
Switching Frequency Range			0.2	--	2		
EN Input Voltage	Logic-High	$V_{IH}$	Enable high-level input voltage	1.6	--	--	V
	Logic-Low	$V_{IL}$	Enable low-level input voltage	--	--	0.4	

Parameter	Symbol	Test Conditions	Min	Typ	Max	Unit
Switch On-Resistance, High	$R_{DS(ON)_P}$	$I_{LX} = 0.5A$	--	120	180	$m\Omega$
Switch On-Resistance, Low	$R_{DS(ON)_N}$	$I_{LX} = 0.5A$	--	80	120	$m\Omega$
Peak Current Limit	$I_{LIM}$		3.6	4.5	--	A
Under-Voltage Lockout Threshold		$V_{IN}$ Rising	--	2.4	--	V
		$V_{IN}$ Falling	--	2.2	--	
Soft-Start Period	$t_{SS}$	$C_{SS} = 10nF$	--	800	--	$\mu s$
Power Good High Threshold		$V_{FB}$ rising, PGOOD goes high	--	87.5	--	% $V_{OUT}$

**Note 1.** Stresses beyond those listed “Absolute Maximum Ratings” may cause permanent damage to the device. These are stress ratings only, and functional operation of the device at these or any other conditions beyond those indicated in the operational sections of the specifications is not implied. Exposure to absolute maximum rating conditions may affect device reliability.

**Note 2.**  $\theta_{JA}$  is measured at  $T_A = 25^\circ C$  on a high effective thermal conductivity four-layer test board per JEDEC 51-7.  $\theta_{JC}$  is measured at the exposed pad of the package.

**Note 3.** Devices are ESD sensitive. Handling precaution is recommended.

**Note 4.** The device is not guaranteed to function outside its operating conditions.

**Typical Operating Characteristics**

**Efficiency vs. Output Current**

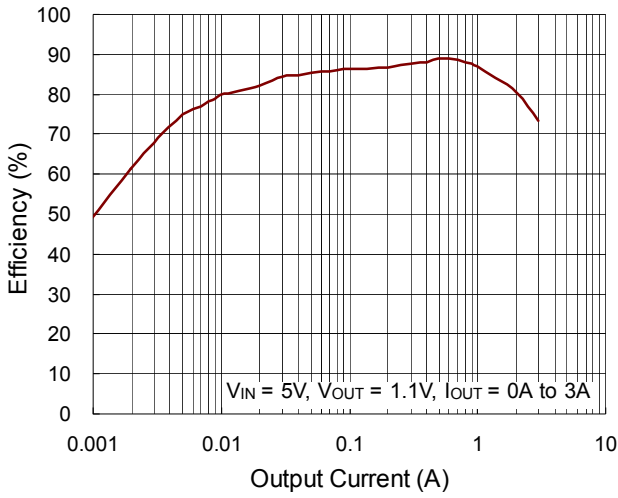

**Efficiency vs. Output Current**

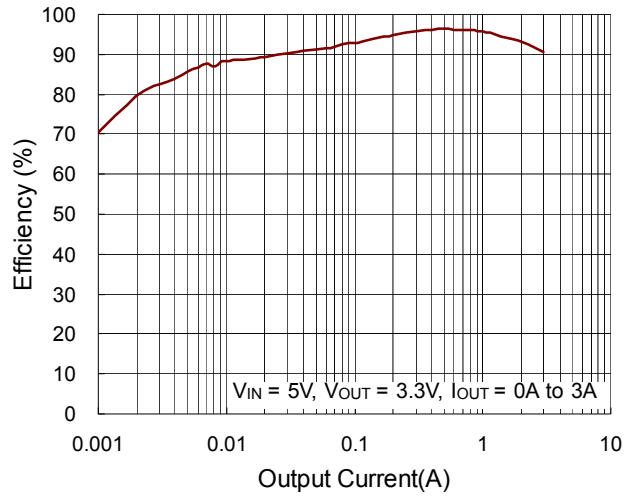

**Output Voltage vs. Output Current**

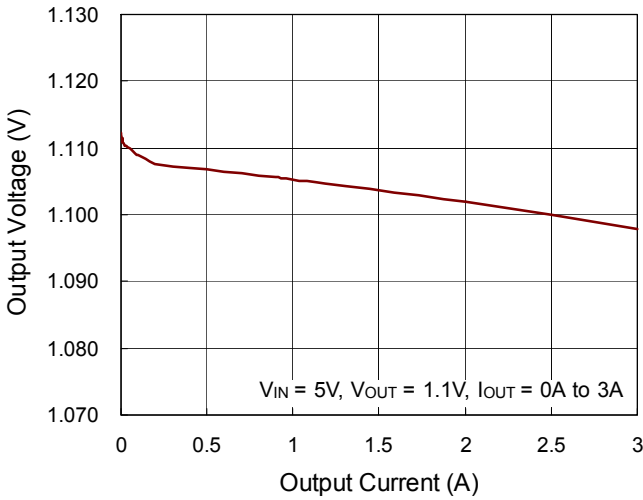

**Output Voltage vs. Output Current**

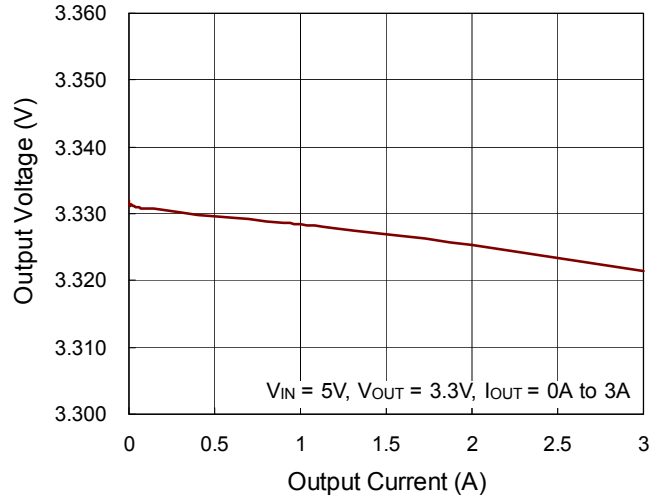

**Switching Frequency vs. Temperature**

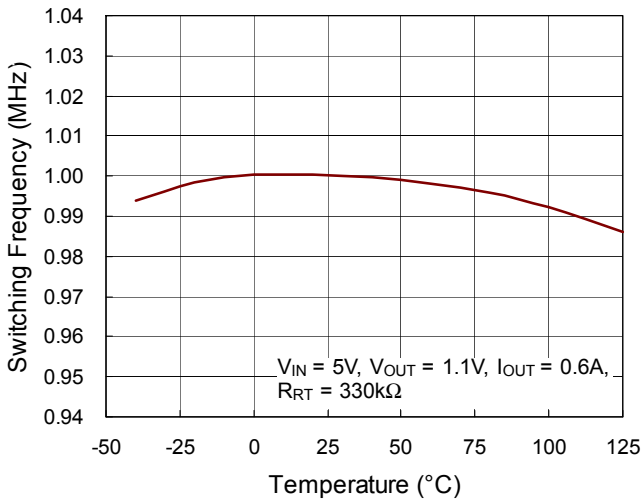

**Reference Voltage vs. Temperature**

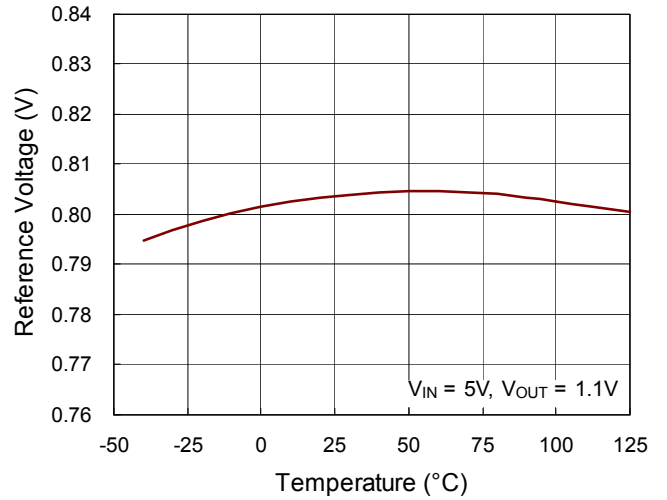

V<sub>IN</sub> UVLO vs. Temperature

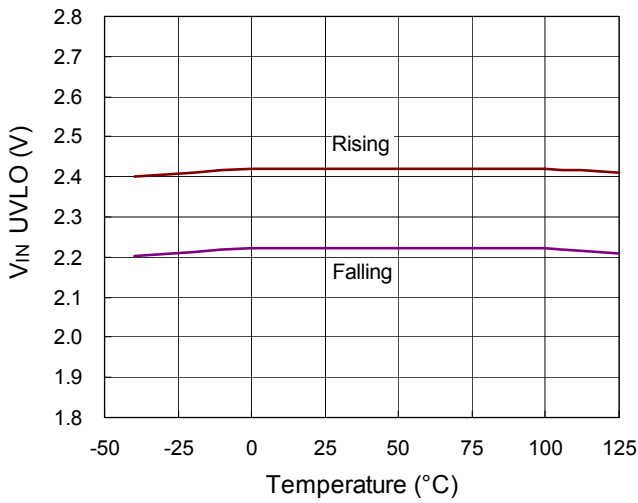

Enable Voltage vs. Temperature

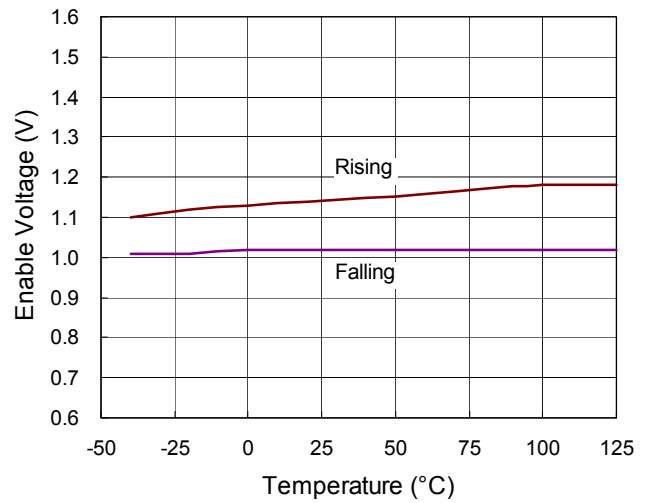

Load Transient Response

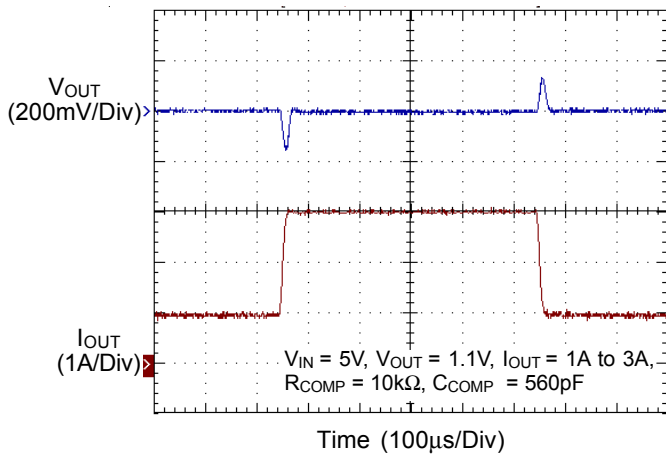

Load Transient Response

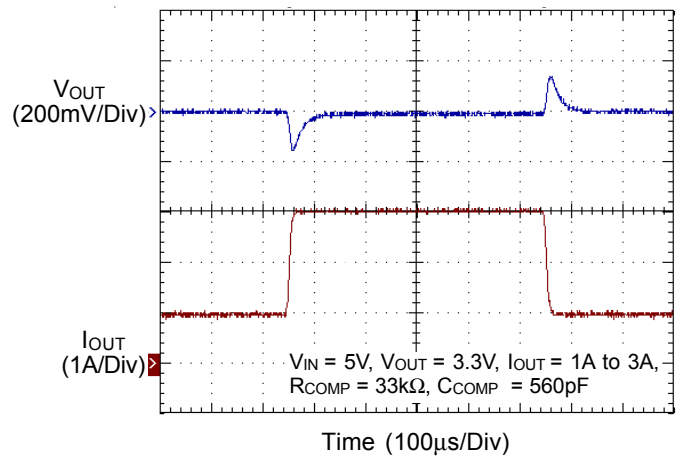

Switching

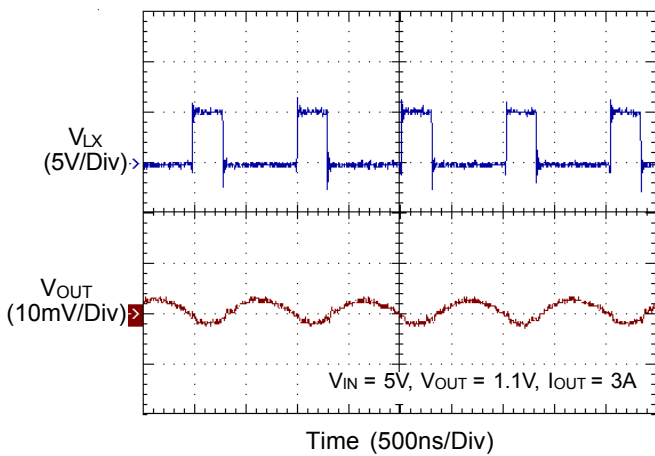

Switching

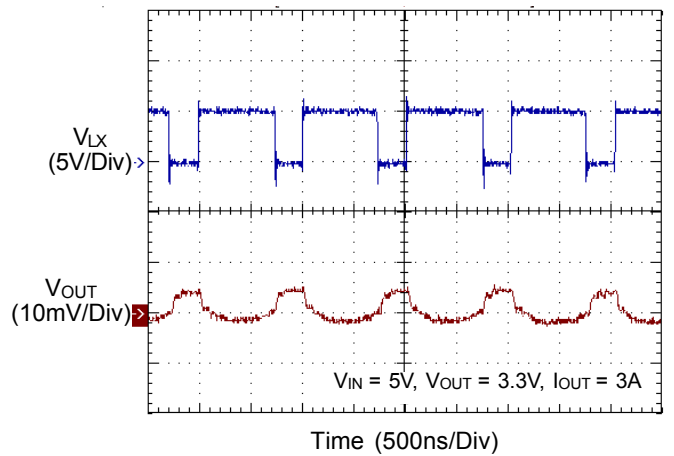



**Power On from  $V_{IN}$**

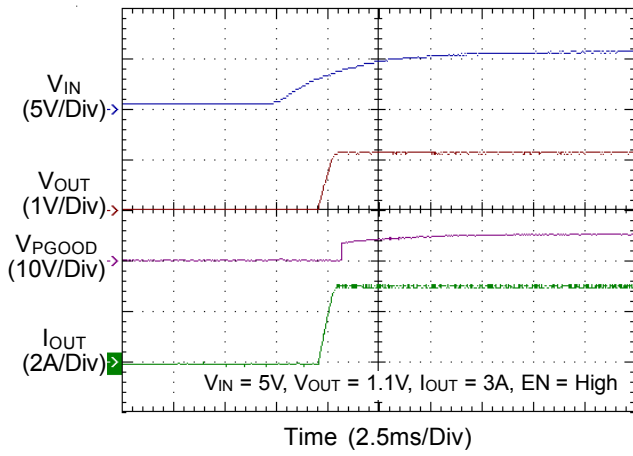

**Power Off from  $V_{IN}$**

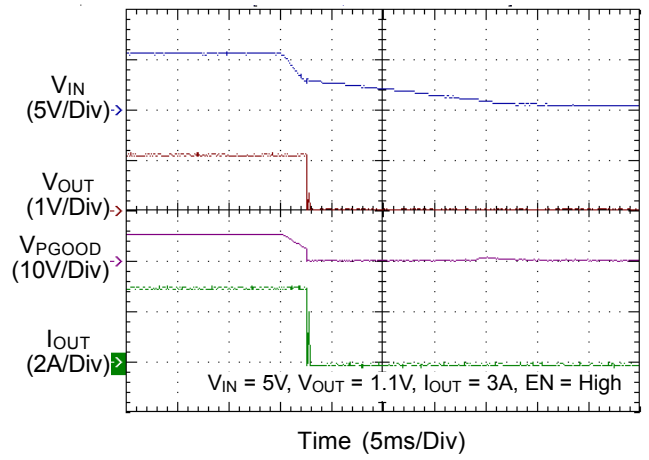

**Power On from EN**

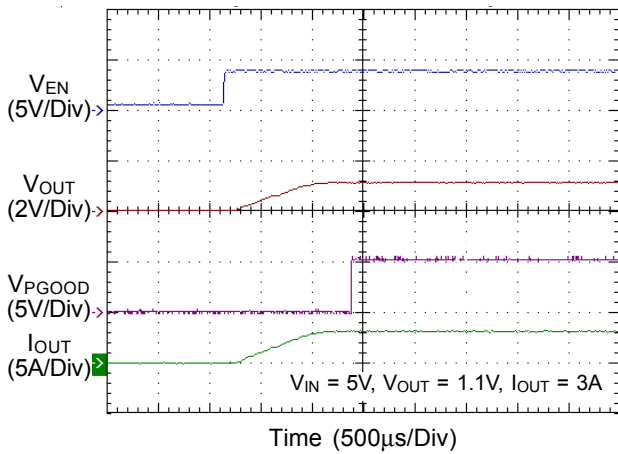

**Power Off from EN**

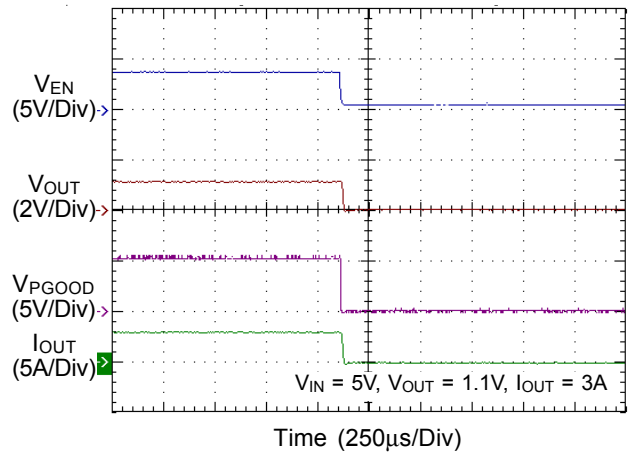

## Application Information

The basic IC application circuit is shown in Typical Application Circuit. External component selection is determined by the maximum load current and begins with the selection of the inductor value and operating frequency followed by  $C_{IN}$  and  $C_{OUT}$ .

### Main Control Loop

During normal operation, the internal upper power switch (P-MOSFET) is turned on at the beginning of each clock cycle. Current in the inductor increases until the peak inductor current reaches the value defined by the output voltage ( $V_{COMP}$ ) of the error amplifier. The error amplifier adjusts its output voltage by comparing the feedback signal from a resistive voltage-divider on the FB pin with an internal 0.8V reference. When the load current increases, it causes a reduction in the feedback voltage relative to the reference. The error amplifier increases its output voltage until the average inductor current matches the new load current. When the upper power MOSFET shuts off, the lower synchronous power switch (N-MOSFET) turns on until the beginning of the next clock cycle.

### Output Voltage Setting

The output voltage is set by an external resistive voltage divider according to the following equation :

$$V_{OUT} = V_{REF} \times \left( 1 + \frac{R1}{R2} \right)$$

where  $V_{REF}$  equals to 0.8V typical.

The resistive voltage divider allows the FB pin to sense a fraction of the output voltage as shown in Figure 1

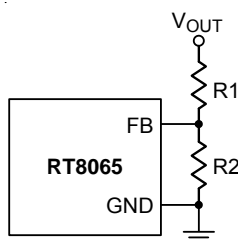

Figure 1. Setting the Output Voltage

### Soft-Start

The RT8065 provides adjustable soft-start function. The soft-start function is used to prevent large inrush current while converter is being powered-up. For the RT8065, the soft-start timing can be programmed by the external capacitor  $C_{SS}$  between SS pin and ground. An internal current source  $I_{SS}$  (10 $\mu$ A) charges an external capacitor to build a soft-start ramp voltage. The  $V_{FB}$  will track the internal ramp voltage during soft-start interval. The typical soft-start time is that  $V_{OUT}$  rises from zero to 90% of setting value and can be calculated by the equation below :

$$t_{SS} = C_{SS} \times \frac{0.8}{I_{SS}}$$

### Power Good Output

The power good output is an open-drain output and requires a pull up resistor. When the output voltage is 12.5% above or 12.5% below its set voltage, PGOOD will be pulled low. It is held low until the output voltage returns to within the allowed tolerances once more. During soft-start, PGOOD is actively held low and is only allowed to transition high when soft-start is over and the output voltage reaches 87.5% of its set voltage.

### Switching Frequency Setting

The RT8065 offers adjustable switching frequency setting and the switching frequency can be set by using external resistor RT. Switching frequency range is from 200kHz to 2MHz. Selection of the operating frequency is a tradeoff between efficiency and component size. High frequency operation allows the use of smaller inductor and capacitor values. Operation at lower frequencies improves efficiency by reducing internal gate charge and transition losses, but requires larger inductance values and capacitance to maintain low output ripple voltage. An additional constraint on operating frequency are the minimum on-time and minimum off-time. The minimum on-time,  $t_{ON\_MIN}$ , is the smallest duration of time in which the high-side switch can be in its "on" state. This time is 90ns (typically). In continuous mode operation, the minimum on-time limit imposes a maximum operating frequency,  $f_{SW\_MAX}$ , of :

$$f_{SW\_MAX} = V_{OUT} / (t_{ON\_MIN} \times V_{IN\_MAX})$$

where  $V_{IN\_MAX}$  is the maximum operating input voltage.

Through external resistor RT connect between RT pin and ground to set the switching frequency  $f_{SW}$ . The equation below shows the relation between setting frequency and RT value.

The switching frequency vs  $R_{RT}$  value can be short with the formula below :

$$f_{SW} \text{ (MHz)} = K \times 0.9 / R_{RT} \text{ (k}\Omega\text{)}$$

where  $K = 3.67 \times 10^5$

Note that the variation of  $f_{SW}$  is  $\pm 15\%$ .

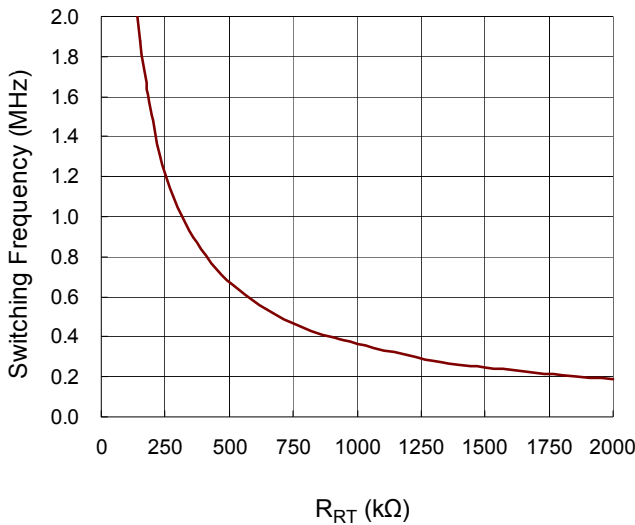

Figure 2. Switching Frequency vs. RT Resistor

**Inductor Selection**

For a given input and output voltage, the inductor value and operating frequency determine the ripple current. The ripple current,  $\Delta I_L$ , increases with higher  $V_{IN}$  and decreases with higher inductance.

$$\Delta I_L = \left[ \frac{V_{OUT}}{f \times L} \right] \times \left[ 1 - \frac{V_{OUT}}{V_{IN}} \right]$$

Having a lower ripple current reduces not only the ESR losses in the output capacitors but also the output voltage ripple. Highest efficiency operation is achieved by reducing ripple current at low frequency, but attaining this goal requires a large inductor.

For the ripple current selection, the value of  $\Delta I_L = 0.4(I_{MAX})$  is a reasonable starting point. The largest ripple current occurs at the highest  $V_{IN}$ . To guarantee that the ripple current stays below a specified maximum value, the

inductor value needs to be chosen according to the following equation :

$$L = \left[ \frac{V_{OUT}}{f \times \Delta I_L(MAX)} \right] \times \left[ 1 - \frac{V_{OUT}}{V_{IN(MAX)}} \right]$$

**Using Ceramic Input and Output Capacitors**

Higher values, lower cost ceramic capacitors are now becoming available in smaller case sizes. Their high ripple current, high voltage rating and low ESR make them ideal for switching regulator applications. However, care must be taken when these capacitors are used at the input and output. When a ceramic capacitor is used at the input and the power is supplied by a wall adapter through long wires, a load step at the output can induce ringing at the input. At best, this ringing can couple to the output and be mistaken as loop instability. At worst, a sudden inrush of current through the long wires can potentially cause a voltage spike at  $V_{IN}$  large enough to damage the part.

**Slope Compensation and Peak Inductor Current**

Slope compensation provides stability in constant frequency architectures by preventing sub- harmonic oscillations at duty cycles greater than 50%. It is accomplished internally by adding a compensating ramp to the inductor current signal. Normally, the peak inductor current is reduced when slope compensation is added. For the IC, however, separated inductor current signal is used to monitor over current condition, so the maximum output current stays relatively constant regardless of the duty cycle.

**Hiccup Mode Under-Voltage Protection**

A Hiccup Mode under-voltage protection (UVP) function is provided for the IC. When the FB voltage drops below half of the feedback reference voltage,  $V_{FB}$ , the UVP function is triggered to auto re-soft-start the power stage until this event is cleared. The Hiccup Mode UVP reduces the input current in short circuit conditions, but will not be triggered during soft-start process.

**Under-Voltage Lockout Threshold**

The RT8065 includes an input under-voltage lockout protection (UVLO) function. If the input voltage exceeds

the UVLO rising threshold voltage, the converter will reset and prepare the PWM for operation. However, if the input voltage falls below the UVLO falling threshold voltage during normal operation, the device will stop switching. The UVLO rising and falling threshold voltage has a hysteresis to prevent noise-caused reset.

### Over-Temperature Protection

The RT8065 includes an over-temperature protection (OTP) circuitry to prevent overheating due to excessive power dissipation. The OTP will shut down switching operation when junction temperature exceeds a thermal shutdown threshold  $T_{SD}$  (150°C). Once the junction temperature cools down by a thermal shutdown hysteresis ( $\Delta T_{SD} = 20^\circ\text{C}$ ), the IC will resume normal operation with a complete soft-start.

### Thermal Considerations

For continuous operation, do not exceed absolute maximum junction temperature. The maximum power dissipation depends on the thermal resistance of the IC package, PCB layout, rate of surrounding airflow, and difference between junction and ambient temperature. The maximum power dissipation can be calculated by the following formula :

$$P_{D(MAX)} = (T_{J(MAX)} - T_A) / \theta_{JA}$$

where  $T_{J(MAX)}$  is the maximum junction temperature,  $T_A$  is the ambient temperature, and  $\theta_{JA}$  is the junction to ambient thermal resistance.

For recommended operating condition specifications, the maximum junction temperature is 125°C. The junction to ambient thermal resistance,  $\theta_{JA}$ , is layout dependent. For SOP-8 (Exposed Pad) packages, the thermal resistance,  $\theta_{JA}$ , is 75°C/W on a standard JEDEC 51-7 four-layer thermal test board. For WDFN-8L 3x3 packages, the thermal resistance,  $\theta_{JA}$ , is 70°C/W on a standard JEDEC 51-7 four-layer thermal test board. The maximum power dissipation at  $T_A = 25^\circ\text{C}$  can be calculated by the following formulas :

$$P_{D(MAX)} = (125^\circ\text{C} - 25^\circ\text{C}) / (75^\circ\text{C/W}) = 1.333\text{W for SOP-8 (Exposed Pad) package.}$$

$$P_{D(MAX)} = (125^\circ\text{C} - 25^\circ\text{C}) / (70^\circ\text{C/W}) = 1.429\text{W for}$$

WDFN-8L 3x3 package.

The maximum power dissipation depends on the operating ambient temperature for fixed  $T_{J(MAX)}$  and thermal resistance,  $\theta_{JA}$ . The derating curves in Figure 3 allow the designer to see the effect of rising ambient temperature on the maximum power dissipation.

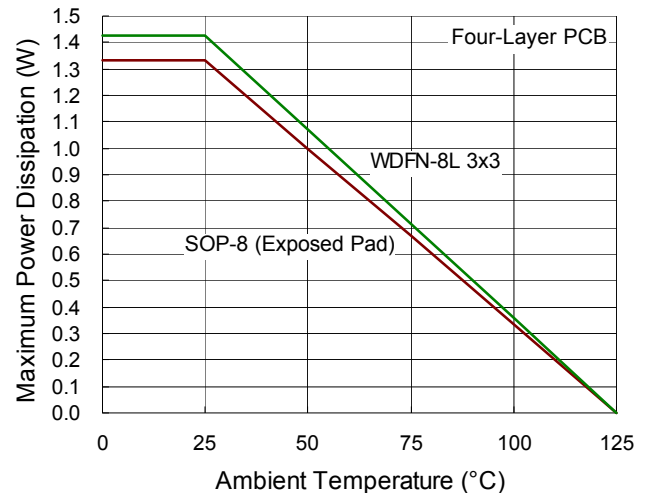

Figure 3. Derating Curve of Maximum Power Dissipation

### Layout Considerations

Follow the PCB layout guidelines for optimal performance of the IC.

- ▶ Connect the terminal of the input capacitor(s),  $C_{IN}$ , as close to the VIN pin as possible. This capacitor provides the AC current into the internal power MOSFETs.
- ▶ LX node experiences high frequency voltage swings so should be kept within a small area.
- ▶ Keep all sensitive small signal nodes away from the LX node to prevent stray capacitive noise pick up.
- ▶ Connect the FB pin directly to the feedback resistors. The resistive voltage-divider must be connected between  $V_{OUT}$  and GND.

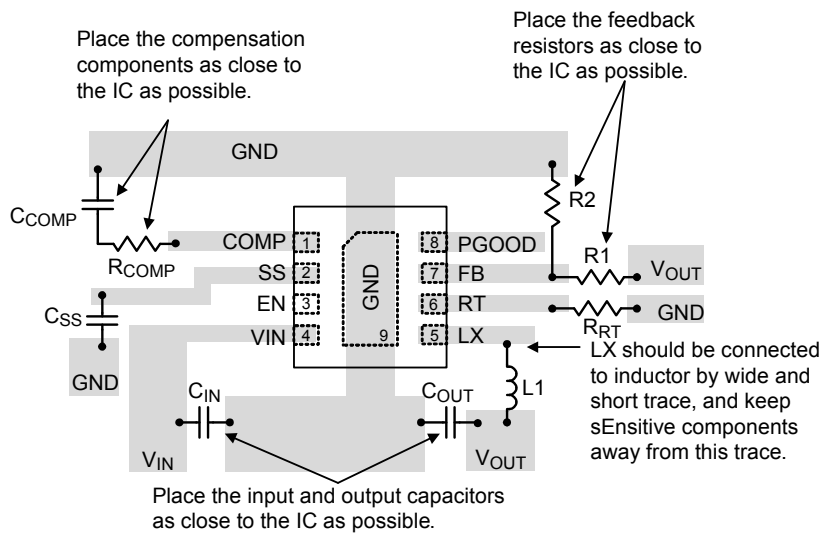
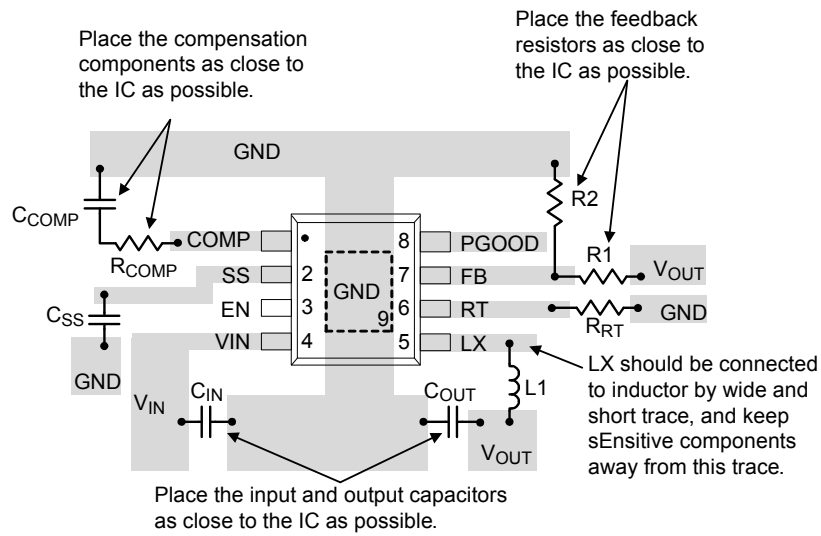
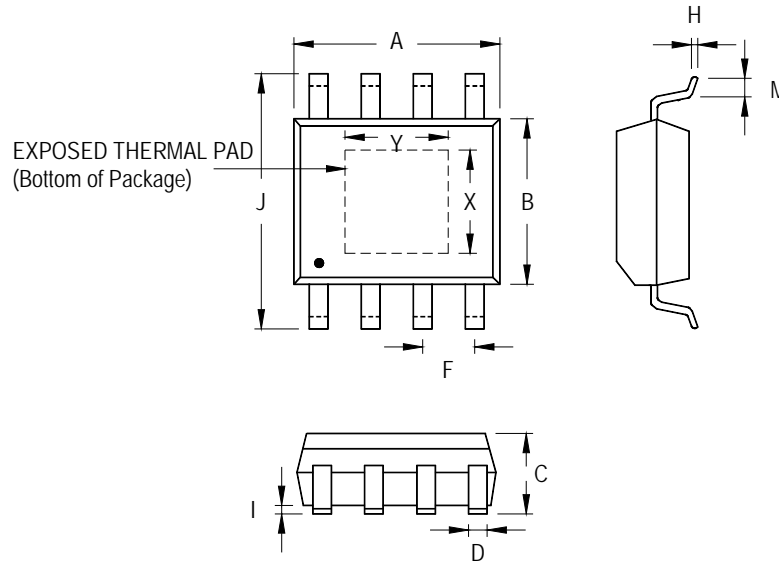

Figure 4. PCB Layout Guide

Outline Dimension



Symbol	Dimensions In Millimeters		Dimensions In Inches		
	Min	Max	Min	Max	
A	4.801	5.004	0.189	0.197	
B	3.810	4.000	0.150	0.157	
C	1.346	1.753	0.053	0.069	
D	0.330	0.510	0.013	0.020	
F	1.194	1.346	0.047	0.053	
H	0.170	0.254	0.007	0.010	
I	0.000	0.152	0.000	0.006	
J	5.791	6.200	0.228	0.244	
M	0.406	1.270	0.016	0.050	
Option 1	X	2.000	2.300	0.079	0.091
	Y	2.000	2.300	0.079	0.091
Option 2	X	2.100	2.500	0.083	0.098
	Y	3.000	3.500	0.118	0.138

8-Lead SOP (Exposed Pad) Plastic Package