

RTKA211605DR0010BU

The RTKA211605DR0010BU board is designed to demonstrate and quickly evaluate the [RAA211605](#), a DC/DC step-down regulator with 450 kHz switching frequency.

The RAA211605 supports a wide input voltage range (from 4.5V to 60V) and adjustable output voltage. It can deliver up to 0.5A continuous output current with premium load regulation and line regulation performance.

The demonstration board implements a complete buck regulator using the RAA211605. The output voltage is set to 3.3V but can be adjusted by changing the resistor values in the feedback network.

Features

- Simple and flexible design
- Wide input voltage range: 4.5V to 60V
- Adjustable output voltage
- Convenient power conversion

Specifications

The following are the design specifications for the RTKA211605DR0010BU:

- Input voltage (V_{IN}): 4.5V to 60V
- Output voltage (V_{OUT}): 3.3V
- Maximum output current: 0.5A

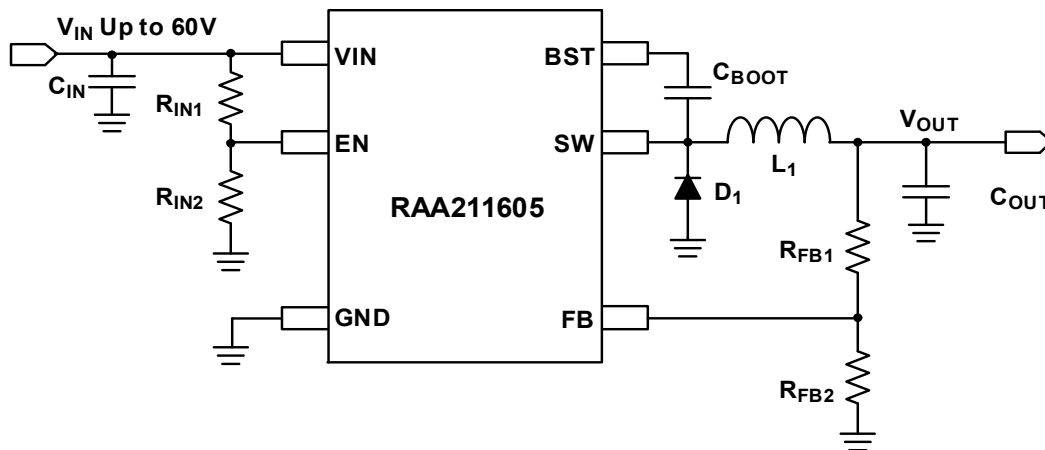

Figure 1. Block Diagram

Contents

1. Functional Description	3
1.1 Setting the Output Voltage	3
1.2 Quick Test Setup	3
2. Board Design	4
2.1 Circuit Schematic	5
2.2 Bill of Materials	6
2.3 Board Layout	7
3. Typical Performance Curves	8
4. Ordering Information	9
5. Revision History	9

1. Functional Description

The RAA211605 is an easy-to-use Buck switching regulator with an integrated 600mΩ high-side MOSFET. The RTKA211605DR0010BU board demonstrates the operations of RAA211605. It allows you to evaluate the performance of the part with different application circuits. It also provides you a reference for board layout.

1.1 Setting the Output Voltage

The output voltage is set to 3.3V by default and can be changed by changing the values of R₃ and R₄ in the feedback resistor network based on Equation 1:

$$(EQ. 1) \quad R_3 = R_4 \cdot \frac{V_{out} - 0.8}{0.8}$$

For applications where the V_{IN} - V_{OUT} is larger than 3V, Renesas recommends using a 20kΩ resistor for R₄ and choose R₃ based on Equation 1. For applications where V_{IN} - V_{OUT} is less than 3V, Renesas recommends using smaller R₃ and R₄ such that there is larger than 50mA load at V_{OUT}.

1.2 Quick Test Setup

1. EN is tied to VIN by default through a 0Ω resistor on R₁, but R₁ and R₂ can also be used to set the input undervoltage lockout level.
2. Connect the power supply to the input terminals VIN(T1) and GND(T2). Connect the load to the output terminals VOUT(T3) and GND(T4). **Important:** Ensure the setup is correctly connected before applying any power or load to the board.
3. Turn on the power supply and the part should start operating.
4. Verify that the output voltage is 3.3V and phase node waveforms can be monitored at J2.

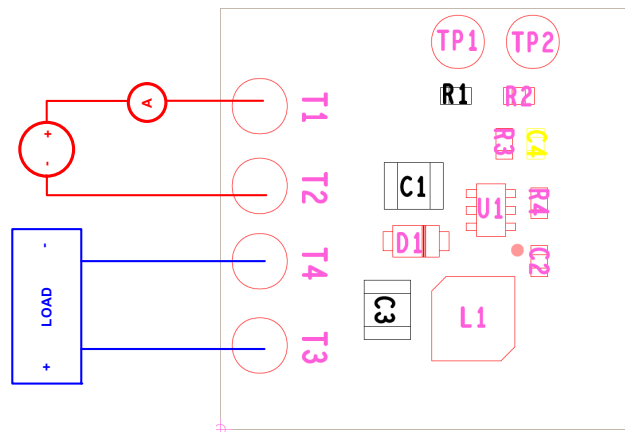

Figure 2. RTKA211605DR0010BU Board Setup

2. Board Design

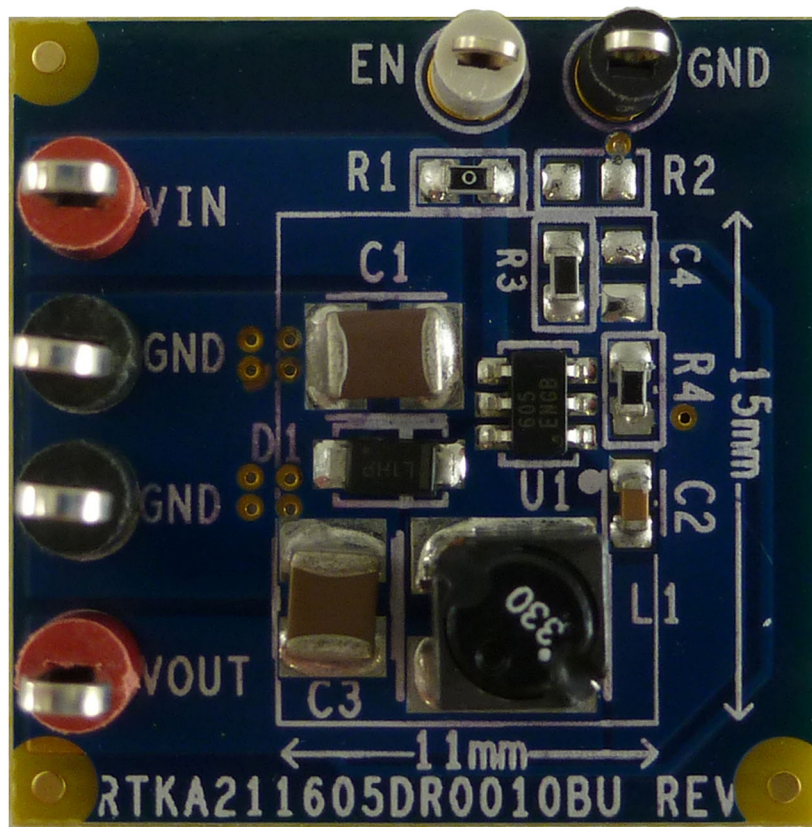

Figure 3. Top View

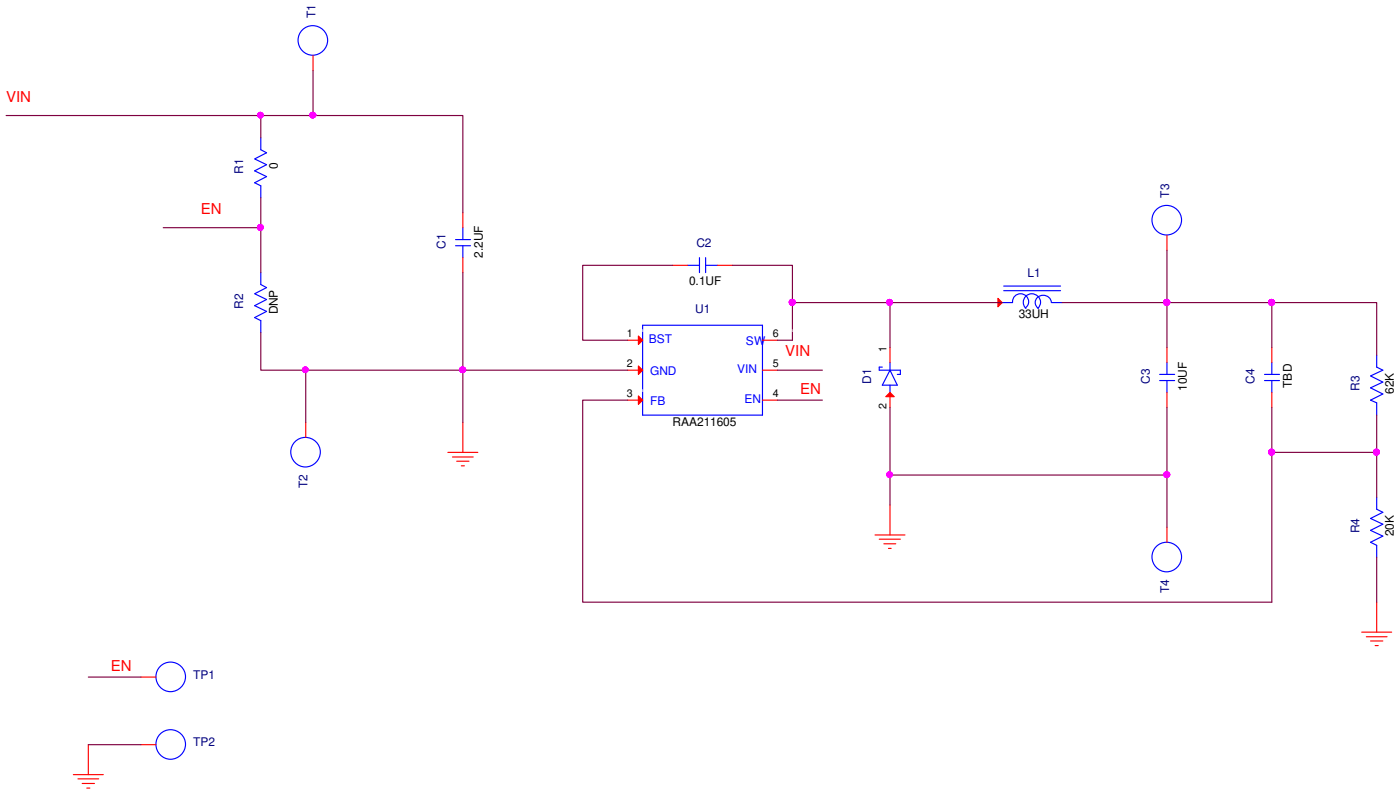

Figure 4. RTKA211605DR0010BU Schematic

2.1 Circuit Schematic

2.2 Bill of Materials

Qty	Reference Designator	Description	Manufacturer	Manufacturer Part
1		PWB-PCB, RTKA211605DR0010BU, REVA, ROHS	Imagineering Inc	RTKA211605DR0010BURVAPCB
1	C3	CAP, SMD, 1210, 10 μ F, 16V, 10%, X7R, ROHS	Murata	GRM32DR71C106KA01L
1	C2	CAP, SMD, 0603, 0.1 μ F, 16V, 10%, X7R, ROHS	Murata	GCM188R71C104KA37D
0	C4	CAP, SMD, 0603, DNP-PLACE HOLDER, ROHS		
1	C1	CAP, SMD, 1210, 2.2 μ F, 100V, 10%, X7R, ROHS	Murata	GRM32ER72A225KA35L
1	L1	COIL-PWR INDUCTOR, SMD, 4.8mm, 33 μ H, 20%, 1.2A, ROHS	Würth Electronics	74408943330
1	TP2	CONN-MINI TEST PT, VERTICAL, BLK, ROHS	Keystone	5001
1	TP1	CONN-MINI TEST POINT, VERTICAL, WHITE, ROHS	Keystone	5002
2	T1, T3	CONN-MULTI-PURPOSE TEST PT, RED, ROHS	Keystone	5010
2	T2, T4	CONN-MULTI-PURPOSE TEST PT, BLK, ROHS	Keystone	5011
1	D1	DIODE-RECTIFIER, SMD, 2P, SOD-123FL, 100V, 1A, ROHS	On Semiconductor	MBR1H100SFT3G
1	U1	IC-60V SYNCHRONOUS BUCK CONVERTER, 6P, TSOT-23, ROHS	Renesas Electronics	RAA2116054GP3#JA0
1	R3	RES-AEC-Q200, SMD, 0603, 62k, 1/10W, 1%, ROHS	Panasonic	ERJ-3EKF6202V
0	R2	RESISTOR, SMD, 0603, 0.1%, MF, DNP-PLACE HOLDER		
1	R1	RES, SMD, 0603, 0 Ω , 1/10W, TF, ROHS	Venkel	CR0603-10W-000T
1	R4	RES, SMD, 0603, 20k, 1/10W, 1%, TF, ROHS	Venkel	CR0603-10W-2002FT
1	Apply to bottom center PCB	BUMPONS, 0.5x0.5inch, SQUARE, TAPERED, BLK, ROHS	3M	SJ-5008-BLACK

2.3 Board Layout

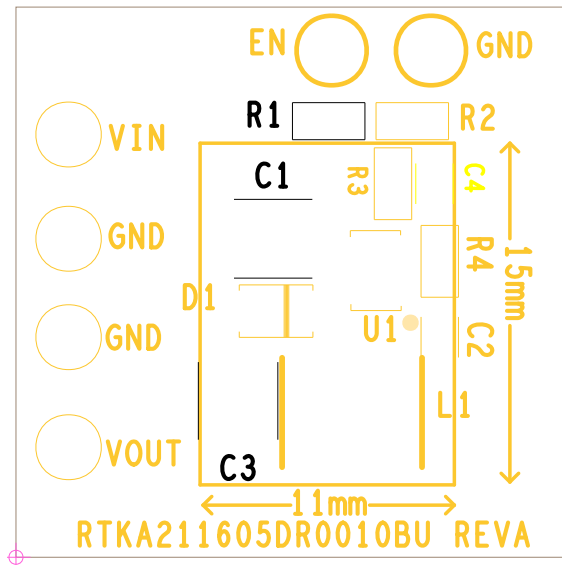

Figure 5. Silkscreen Top

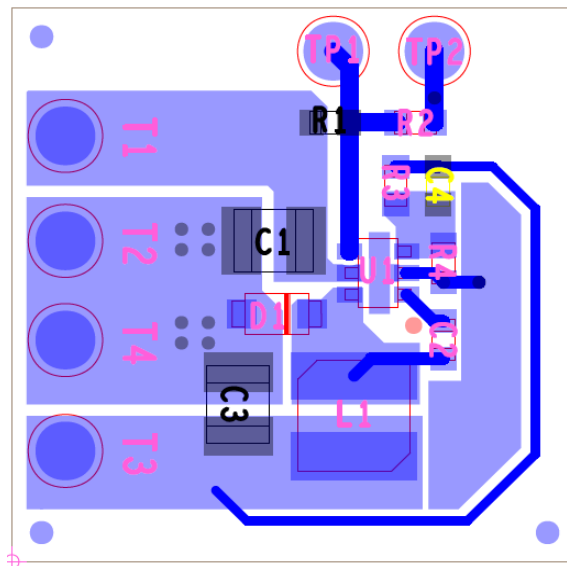

Figure 6. Top Layer

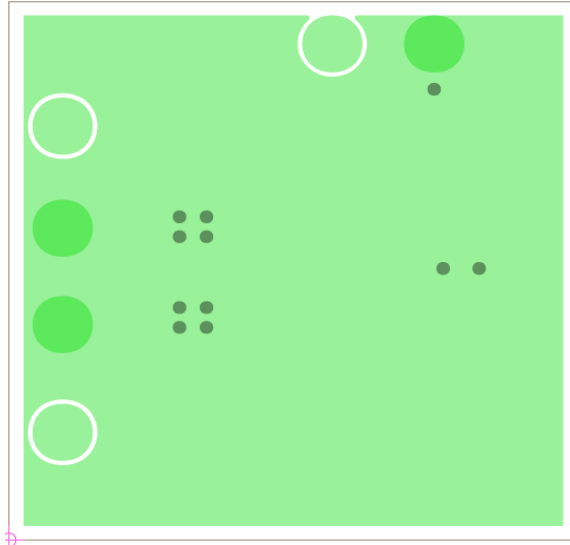

Figure 7. Bottom Layer

3. Typical Performance Curves

$V_{IN} = 24V$, $V_{OUT} = 3.3V$, $T_A = +25^{\circ}C$, unless otherwise noted.

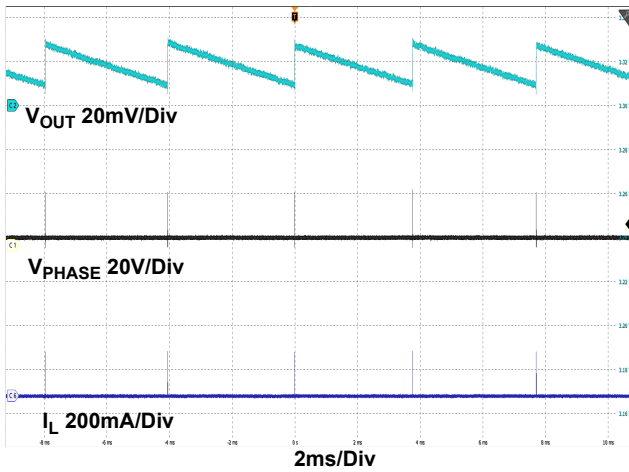

Figure 8. Output Ripple at No Load

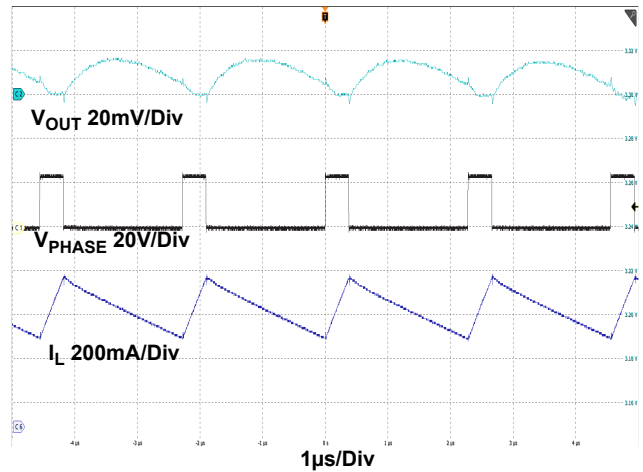

Figure 9. Output Ripple at Full Load

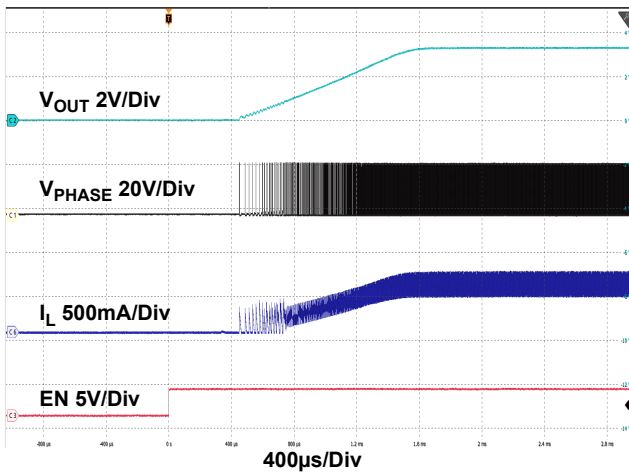

Figure 10. Enable On at Full Load

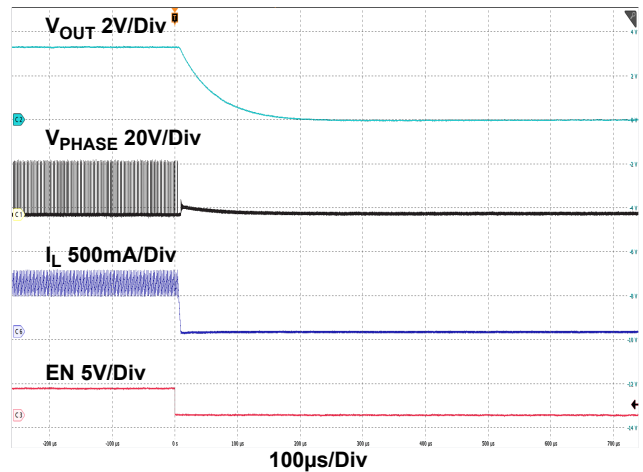

Figure 11. Enable Off at Full Load

$V_{IN} = 24V$, $V_{OUT} = 3.3V$, $T_A = +25^{\circ}C$, unless otherwise noted. (Cont.)

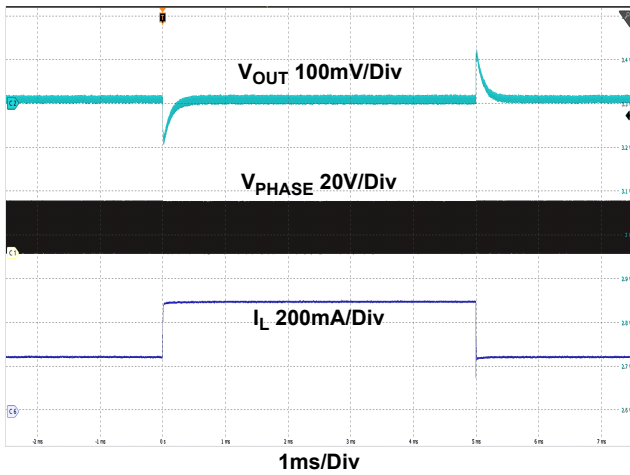

Figure 12. Load Transient between 0.25A and 0.5A

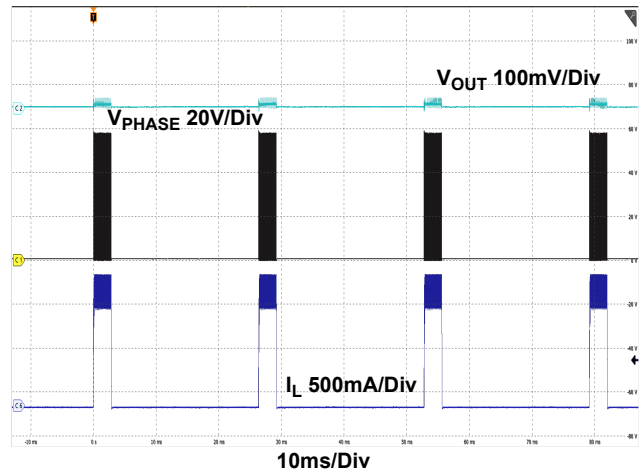

Figure 13. V_{OUT} UVP ($V_{IN} = 60V$)

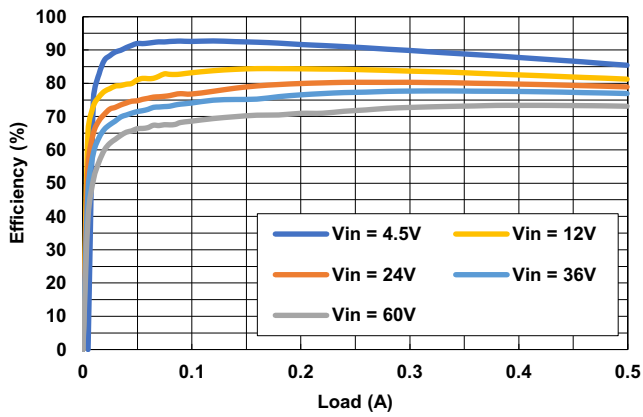

Figure 14. Efficiency vs Load

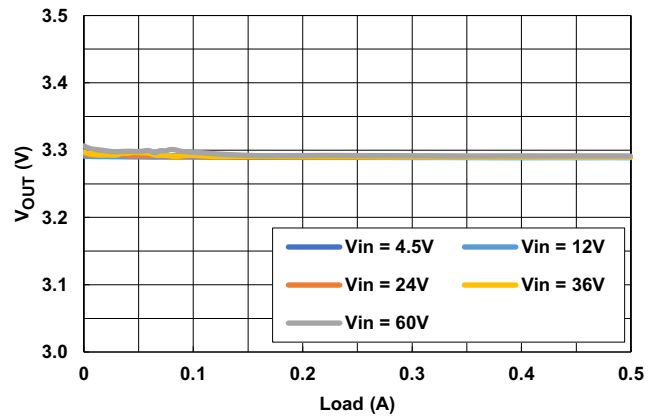

Figure 15. Load Regulation vs Input Voltage

4. Ordering Information

Part Number	Description
RTKA211605DR0010BU	RAA211605 Demonstration Board

5. Revision History

Revision	Date	Description
1.01	May 9, 2022	Updated BOM.
1.00	Jul 13, 2021	Initial release