

High-Side Measurement Current Shunt Monitor with Comparator

General Description

The RTQ6050/RTQ6052 devices are high-side current-shunt monitors which contain a current-sense amplifier, bandgap reference, and a comparator with latching output. The RTQ6050/RTQ6052 senses drops across shunts at common-mode voltages from 2V to 80V. The RTQ6050/RTQ6052 series supports two output voltage scales : 20V/V, and 100V/V.

The RTQ6050 and RTQ6052 build in an open-drain comparator and internal reference providing a 0.6V threshold. External dividers set the current trip point. The comparator features a latching capability, that can be made easily by grounding (or leaving open) the RESET pin.

The RTQ6050/RTQ6052 is available in a small 8-pins MSOP package.

Features

- High Accuracy Current Sensing :
- 3.5% Maximum Error Over Temperature
- 2.9V to 18V Power-Supply Range
- Two Gain Options Available
 - ▶ RTQ6050 = 20V/V
 - ▶ RTQ6052 = 100V/V
- Common-Mode Range : 2V to 80V
- 0.6V Internal Voltage Reference
- Internal Open-Drain Comparator
- Latching Capability on Comparator
- Packages : MSOP-8

Applications

- Server, Storage and Network Equipment
- Portable, Battery-Powered Systems
- Point of Load (POL) Power Modules
- Notebook Computers
- High End Digital TVs

Simplified Application Circuit

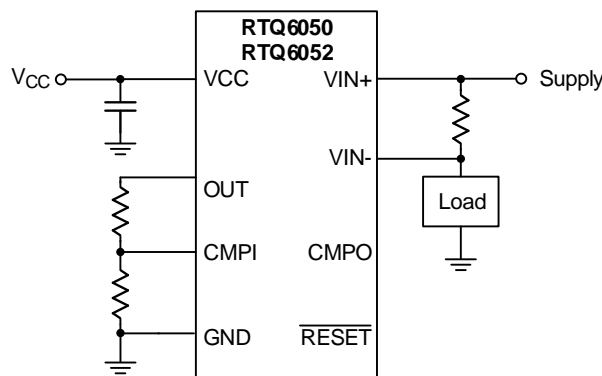

Ordering Information

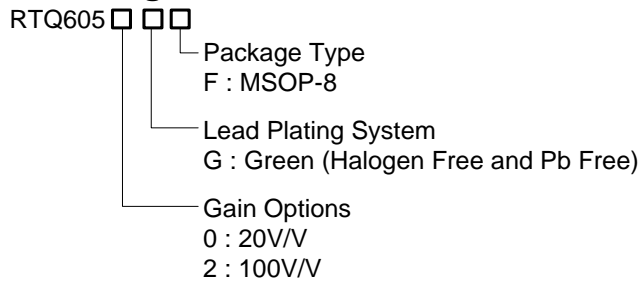

Note :

Richtek products are :

- ▶ RoHS compliant and compatible with the current requirements of IPC/JEDEC J-STD-020.
- ▶ Suitable for use in SnPb or Pb-free soldering processes.

Pin Configuration

(TOP VIEW)

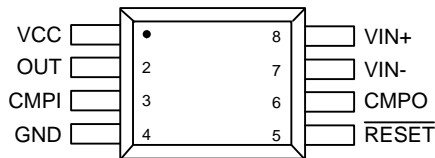

MSOP-8

Marking Information

RTQ6050GF

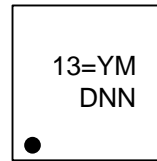

13= : Product Code
YMDNN : Date Code

RTQ6052GF

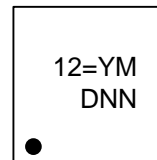

12= : Product Code
YMDNN : Date Code

Functional Pin Description

Pin No.	Pin Name	Pin Function
1	VCC	Power input. Connect a 0.1μF capacitor as close to the VCC pin as possible.
2	OUT	Voltage output. V _{OUT} is proportional to V _{SENSE} (VIN+ – VIN-).
3	CMPI	Comparator input. Positive input of an internal comparator. The negative terminal is connected to a 0.6V internal reference.
4	GND	Ground.
5	$\overline{\text{RESET}}$	Reset input pin. Reset the output latch of the comparator, active low.
6	CMPO	Open-drain comparator output. Connect $\overline{\text{RESET}}$ to GND to disable the latch.
7	VIN-	Negative current-sensing input. Connect load side to external sense resistor.
8	VIN+	Positive current-sensing input. Connect power side to external sense resistor.

Functional Block Diagram

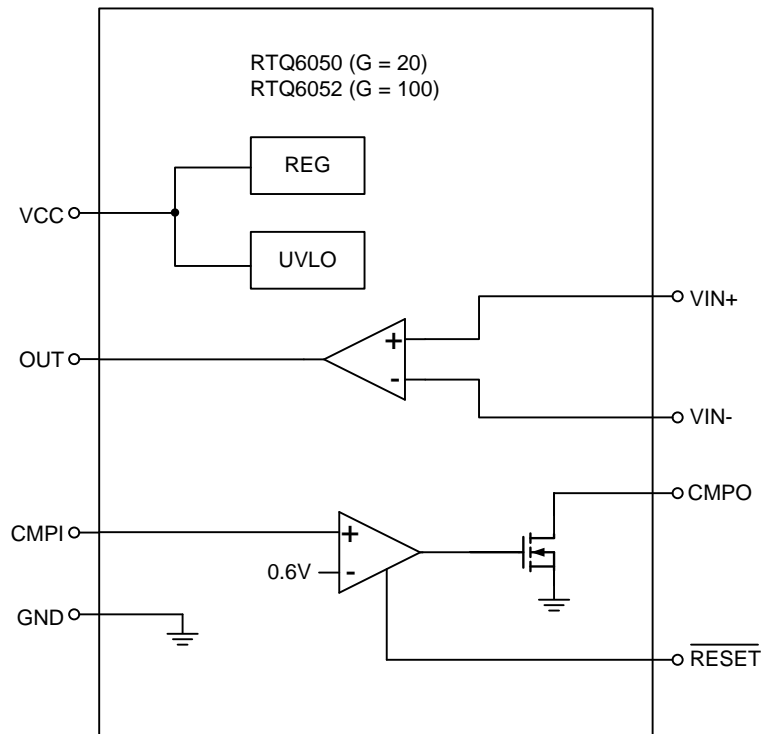

Operation

The RTQ6050/RTQ6052 devices are high-side, unidirectional, current-shunt monitors with a high common-mode input range from 2V to 80V. The devices are available with two output voltage scales: 20V/V and 100V/V, with up to 500kHz bandwidth. The over-current protection is also available by internal comparator; when the voltage at CMPI pin is higher than internal reference 0.6V, the CMPO pulls high to indicate over-current situation. Connect a divider from the OUT pin to CMPI pin to set the over-current trip point, the devices provide an open-drain comparator with a latching function that allows the output signal of comparator to be latched or non-latched by $\overline{\text{RESET}}$ pin setting.

Comparator and Reset

The RTQ6050/RTQ6052 devices incorporate an open-drain comparator. This comparator typically has 1.3 μs (typical) response time. The output of the comparator latches and is reset through the $\overline{\text{RESET}}$ pin. From Figure 1, the control logic is described as 3 stages.

Stage1. V_{CMPO} goes high after V_{CMPI} increases and eventually over 0.6V.

Stage2. When V_{RESET} is high, V_{CMPO} is kept high even V_{CMPI} decreases and lower than 0.6V; when the V_{RESET} goes low, V_{CMPO} goes low as well.

Stage3. When V_{RESET} is low, V_{CMPO} goes high/low depending on V_{CMPI} higher/lower than 0.6V.

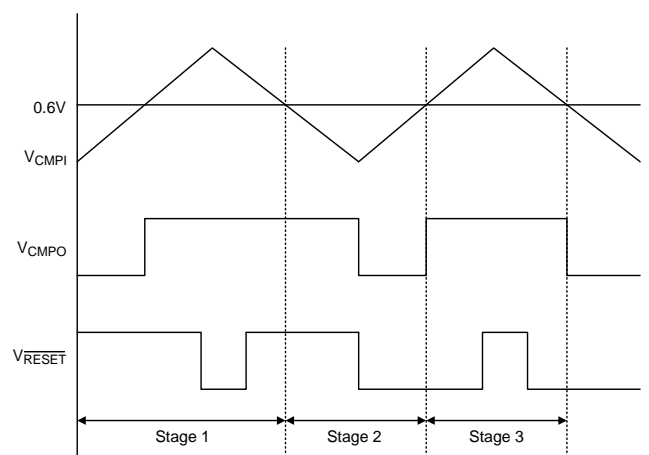
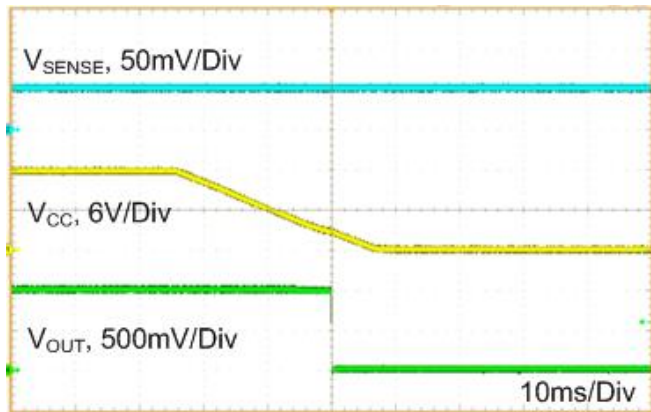
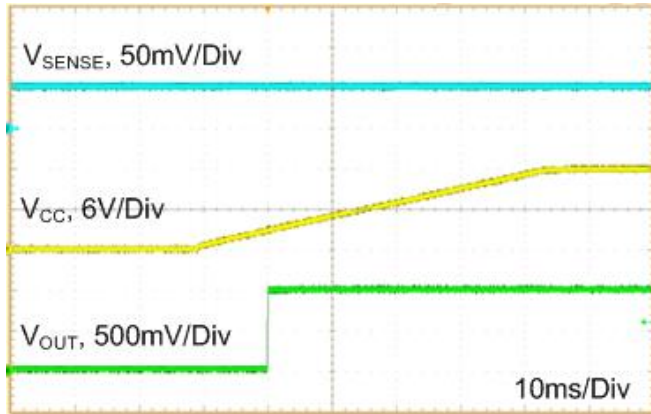

Figure 1. Comparator Latching and Reset Logic

Power On

The RTQ6050/RTQ6052 implements power on reset (POR) function to prevent operation without fully turn-on

the internal control circuit. When V_{CC} is increasing and eventually becomes higher than POR rising threshold (2.75V, typical), the device starts output voltage; in contrast, when V_{CC} is lower than POR falling threshold (2.55V, typical), the device stops output voltage.



Gain Error and Input Offset Voltage

Using two-step method to characterize gain error and offset voltage, first of all, the gain can be obtained by measuring different sense voltage.

$$G = \frac{V_{OUT1} - V_{OUT2}}{100mV - 20mV}$$

Where

- V_{OUT1} = output voltage with V_{SENSE} = 100mV
- V_{OUT2} = output voltage with V_{SENSE} = 20 V

Then the offset voltage is measured at V_{SENSE} = 100mV, and referred to the input (RTI) of the current shunt monitor, as shown in Electrical Characteristics: Current-Shunt Monitor.

$$VRTI \text{ (Referred-To-Input)} = \left(\frac{V_{OUT1}}{G} \right) - 100mV$$

Absolute Maximum Ratings (Note 1)

- Supply Input Voltage, V_{CC} ----- -0.3V to 19.8V
- Power Sensing PINS, V_{IN+} , V_{IN-} (common mode), V_{CM} ----- -6V to 88V
- Power Sensing PINS, V_{IN+} - V_{IN-} (different mode), V_{SENSE} ----- -6V to 18V
- Other Pins, $CMPI$, $CMPO$, OUT , \overline{RESET} ----- -0.3V to 19.8V
- Power Dissipation, P_D @ $T_A = 25^\circ C$
 MSOP-8 ----- 0.27W
- Package Thermal Resistance (Note 2)
 MSOP-8, θ_{JA} ----- 361.6 $^\circ C/W$
 MSOP-8, θ_{JC} ----- 90.4 $^\circ C/W$
- Lead Temperature (Soldering, 10 sec.)----- 260 $^\circ C$
- Junction Temperature ----- 150 $^\circ C$
- Storage Temperature Range ----- -65 $^\circ C$ to 150 $^\circ C$
- ESD Susceptibility (Note 3)
 HBM (Human Body Model) ----- 4kV

Recommended Operating Conditions (Note 4)

- Supply Input Voltage, V_{CC} ----- 2.9V to 18V
- Common mode input range, V_{CM} ----- 2V to 80V
- Ambient Temperature Range ----- -40 $^\circ C$ to 85 $^\circ C$
- Junction Temperature Range ----- -40 $^\circ C$ to 125 $^\circ C$

Electrical Characteristics

($V_{CC} = 12V$, $V_{CM} = 12V$, $T_A = 25^\circ C$, unless otherwise specified)

Parameter	Symbol	Test Conditions	Min	Typ	Max	Unit
Power Supply						
Operating Power Supply	V_{CC}		2.9	--	18	V
Quiescent Current	I_Q	$V_{OUT} = 2V$, $T_A = -40^\circ C$ to 125 $^\circ C$	--	--	1200	μA
		$V_{SENSE} = 0mV$, $T_A = -40^\circ C$ to 125 $^\circ C$	--	--	500	
POR Rising Threshold	V_{PORH}		2.7	2.75	2.85	V
POR Falling Threshold	V_{PORL}		--	2.55	--	V
Current Sense						
Full Scale Sense Input Voltage			--	0.15	--	V
Common Mode Input Range	V_{CM}		2	--	80	V
Common Mode Rejection (Note 5)	CMR	$V_{IN+} = 2V$ to 80V	80	100	--	dB
		$V_{IN+} = 12V$ to 80V $T_A = -40^\circ C$ to 125 $^\circ C$	100	123	--	dB

Parameter	Symbol	Test Conditions	Min	Typ	Max	Unit	
Offset Voltage, RTI	V _{OS}	T _A = 25°C	--	±0.5	±2.5	mV	
		T _A = 25°C to 125°C	--	--	±3	mV	
		T _A = -40°C to 125°C	--	--	±3.5	mV	
Offset Voltage, RTI vs Temperature (Note 5)		T _A = -40°C to 125°C	--	5	--	µV/°C	
PSR of Offset Voltage, RTI	PSR	V _{OUT} = 2V, V _{IN+} = 18V, V _{CC} = 2.9V T _A = -40°C to 125°C	--	2.5	100	µV/V	
Input bias current	I _B	V _{IN-} pin	--	13	--	µA	
Gain	G	RTQ6050	--	20	--	V/V	
		RTQ6052	--	100	--	V/V	
Gain Error	GE%	V _{SENSE} = 20mV to 100mV	--	±0.2	±1	%	
		V _{SENSE} = 20mV to 100mV T _A = -40°C to 125°C	--	--	±2	%	
Total Output Error	ΔV _{OUT} %	V _{SENSE} = 120mV, V _{CC} = 16V	--	±0.75	±2.2	%	
		V _{SENSE} = 120mV, V _{CC} = 16V T _A = -40°C to 125°C	--	--	±3.5	%	
Nonlinearity Error (Note 5)	NLIN%	V _{SENSE} = 20mV to 100mV	--	0.1	--	%	
Maximum Capacitive Load (Note 5)			--	10	--	nF	
Output Voltage Range H		V _{IN-} = 11V, V _{IN+} = 12V T _A = -40°C to 125°C	--	V _{CC} -0.15	--	V	
Output Voltage Range L		V _{IN-} = 0V, V _{IN+} = -0.5V T _A = -40°C to 125°C	RTQ6050	--	4	100	mV
			RTQ6052	--	4	350	
Bandwidth (Note 5)	BW	GAIN = 20, C _{LOAD} = 5pF, unity gain	--	160	--	kHz	
		GAIN = 100, C _{LOAD} = 5pF, unity gain	--	36	--	kHz	
Phase Margin (Note 5)	P.M	C _{LOAD} < 10nF	--	40	--	°	
Slew Rate	SR	RTQ6050	--	0.5	--	V/µs	
		RTQ6052	--	1.5	--		
Settling Time	T _{ST}	V _{SENSE} = 10mV to 100mV 10%~90% V _{OUT} C _{LOAD} = 5pF	RTQ6050	--	2	--	µs
			RTQ6052	--	6	--	
Noise Density, RTI (Note 5)		Frequency = 10k	--	40	--	nV/√Hz	
Comparator							
Threshold	V _{TH}	T _A = -40°C to 125°C	585	600	615	mV	
Hysteresis	V _{HYS}	T _A = -40°C to 85°C	--	-8	--	mV	
Input Bias Current	I _{B_CM}	T _A = 25°C	--	0.005	10	nA	
		T _A = -40°C to 125°C	--	--	15	nA	
Maximum Input			--	V _{CC} -1.5	--	V	

Parameter	Symbol	Test Conditions	Min	Typ	Max	Unit
Output Open-Drain						
Voltage Gain (Note 5)	CMPGAIN		--	200	--	V/mV
Leakage Current	I _{LEAK}		--	0.0001	1	μA
Dropout Voltage	V _{DROP}	I _{LOAD} = 2.35mA	--	125	220	mV
Response Time	T _{RS}	R _L to 5V, C _L = 15pF 100mV input step with 10mV overdrive	--	1.3	--	μs
RESET						
$\overline{\text{RESET}}$ Pin Threshold	VRST_H	High Level	1	--	--	V
	VRST_L	Low Level	--	--	0.4	V
$\overline{\text{RESET}}$ Input Impedance			--	2	--	MΩ
$\overline{\text{RESET}}$ Minimum Pulse Width			--	1.5	--	μs
RESET Propagation Delay			--	1.6	--	μs

Note 1. Stresses beyond those listed under “Absolute Maximum Ratings” may cause permanent damage to the device. These are stress ratings only, and functional operation of the device at these or any other conditions beyond those indicated in the operational sections of the specifications is not implied. Exposure to absolute maximum rating conditions may affect device reliability.

Note 2. θ_{JA} is measured under natural convection (still air) at $T_A = 25^\circ\text{C}$ with the component mounted on a high effective-thermal-conductivity four-layer test board on a JEDEC 51-7 thermal measurement standard.

Note 3. Devices are ESD sensitive. Handling precautions are recommended.

Note 4. The device is not guaranteed to function outside its operating conditions.

Note 5. Specifications are guaranteed by design, not production tested.

Typical Application Circuit

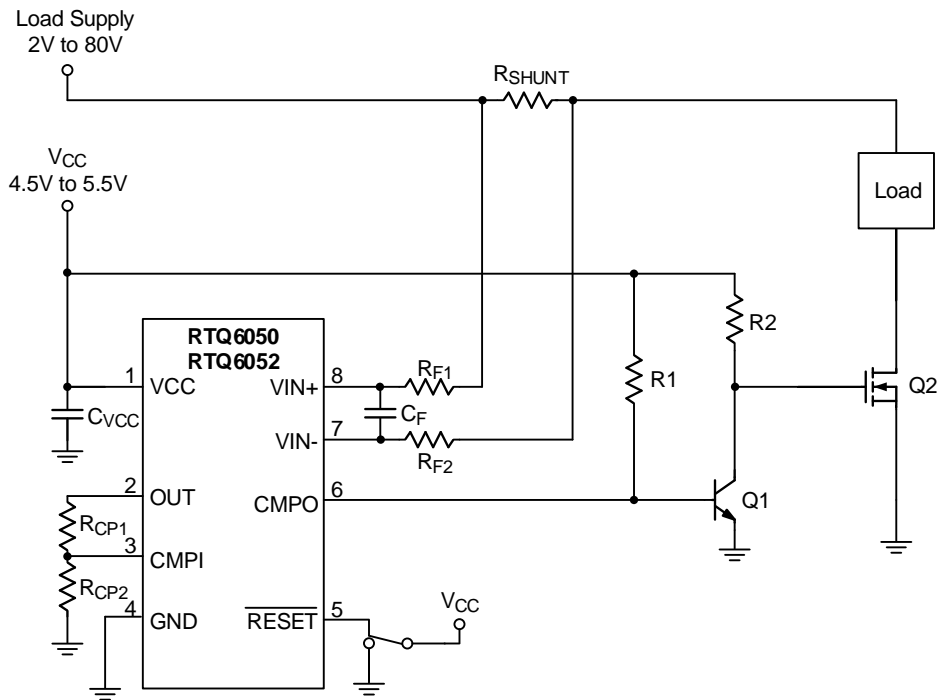

Typical Operating Characteristics

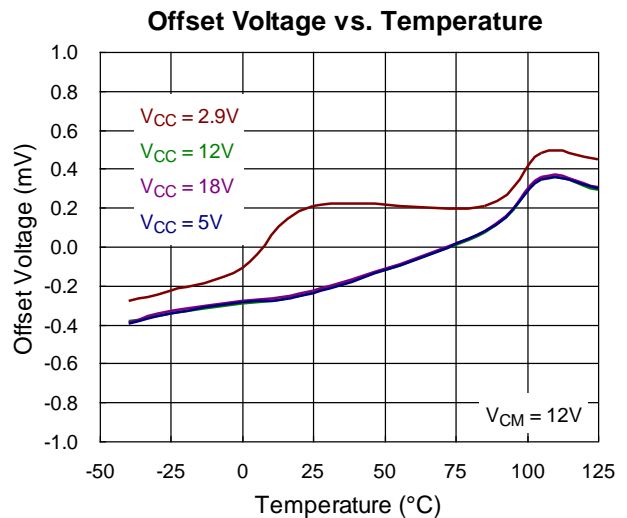
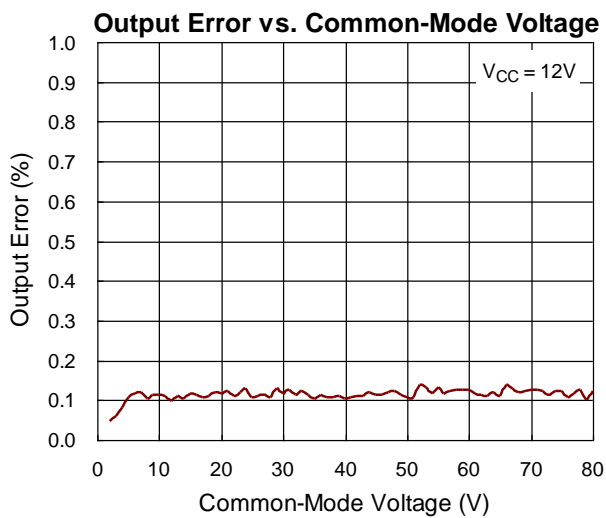
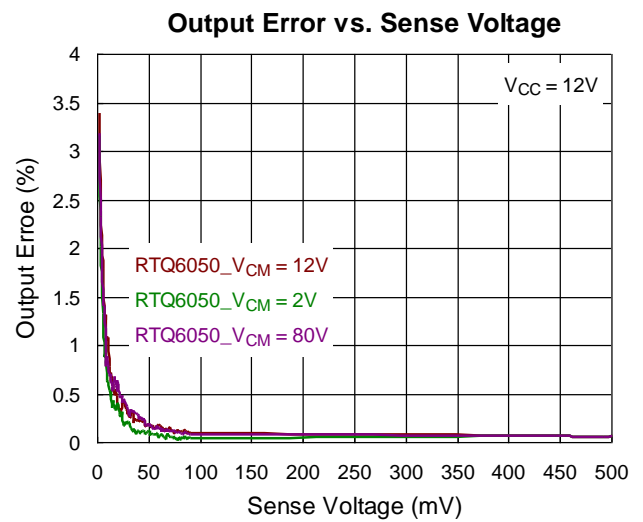
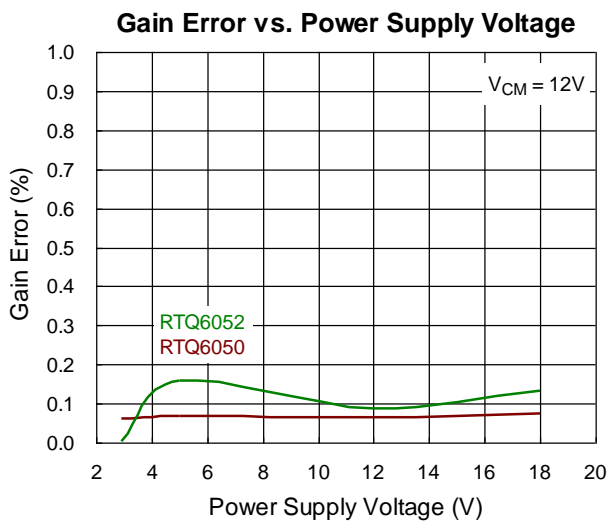
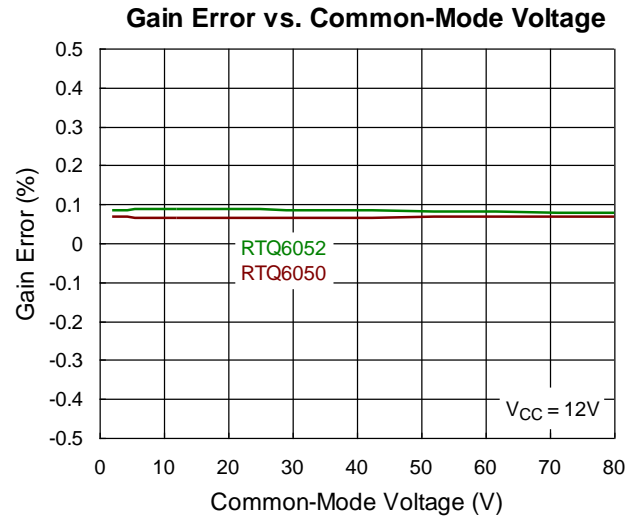
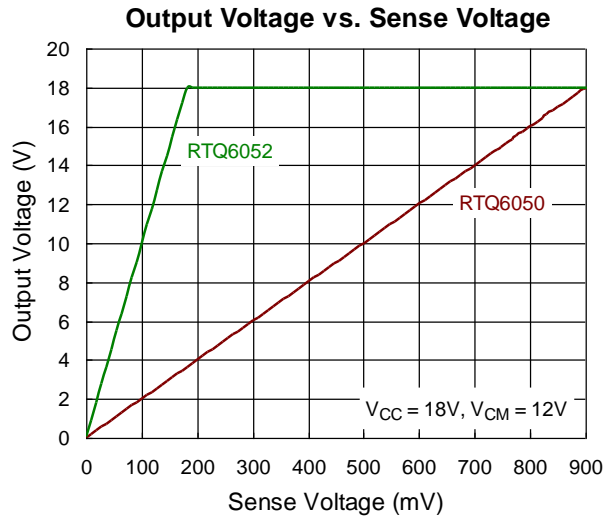

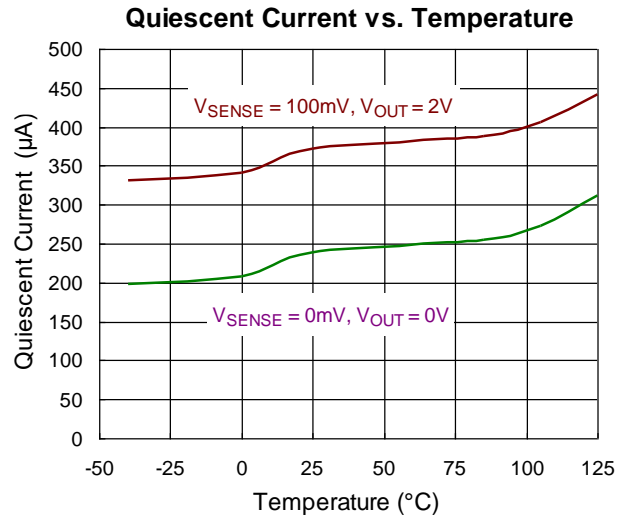
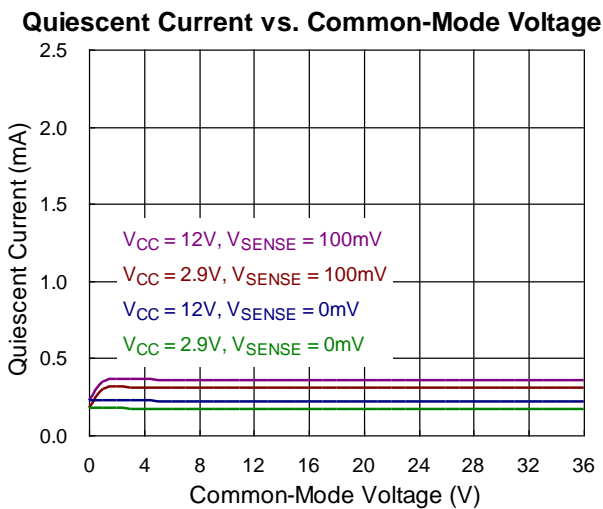
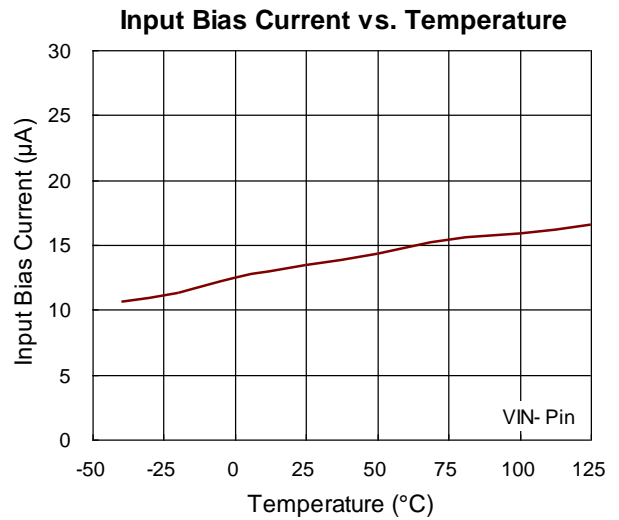
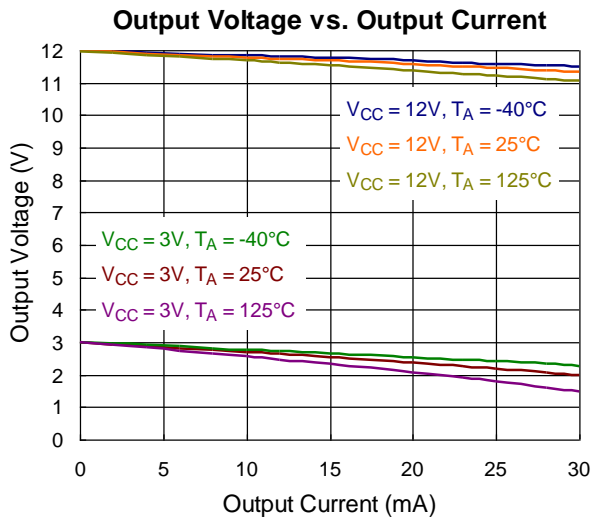
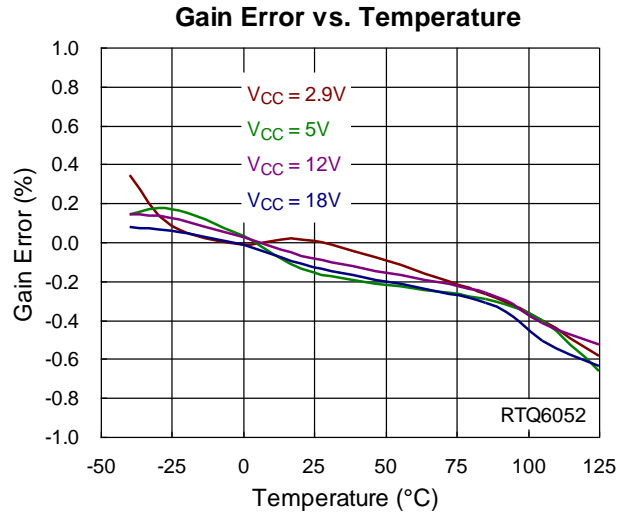
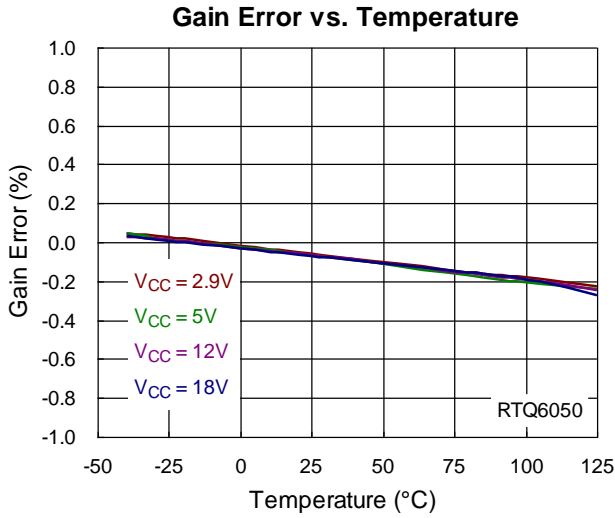

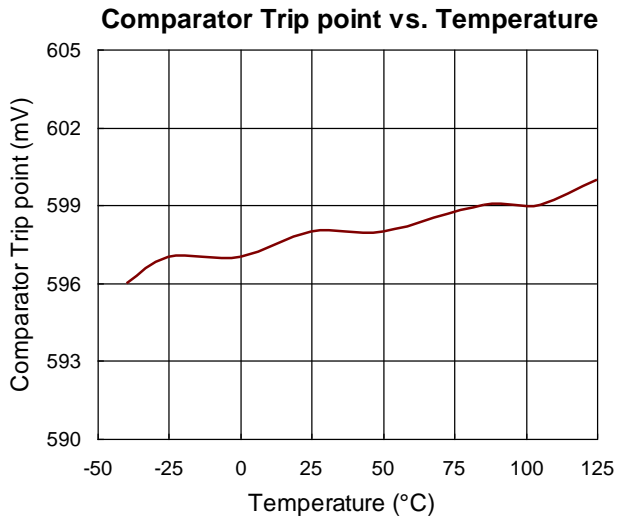

Application Information

Richtek's component specification does not include the following information in the Application Information section. Thereby no warranty is given regarding its validity and accuracy. Customers should take responsibility to verify their own designs and to ensure the functional suitability of their components and systems.

Selecting the Shunt Resistor

The selected value for the shunt resistor, R_{SHUNT}, depends on the application and is a compromise between small-signal accuracy and maximum permissible voltage loss in the measurement line. High values of R_{SHUNT} provide better accuracy at lower currents by minimizing the effects of offset, while low values of R_{SHUNT} minimize voltage loss in the supply line. For best performance, select R_{SHUNT} to provide approximately 50mV to 100mV of sense voltage for the full-scale current in each application. Maximum input voltage for accurate measurements is 500mV, but output voltage is limited by supply voltage V_{CC}.

Input Filtering

In some applications, the current being measured may be inherently noisy. In the case of a noisy signal, filtering after the output of the current sense amplifier is often simpler; however, this location negates the advantage of the low output impedance of the internal buffer.

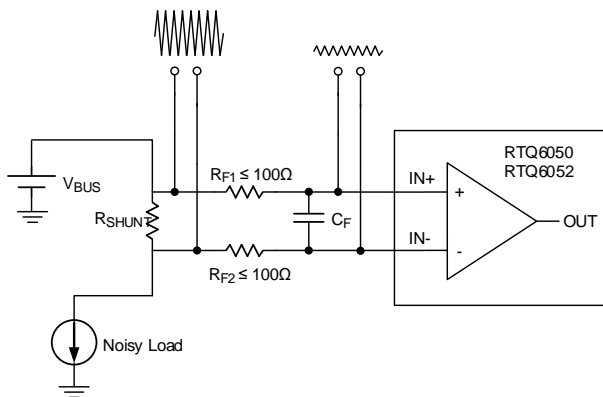

Figure 2. Input Filter

Other applications may require filtering at the input of the current sense amplifier. Figure 2 shows the recommended schematic for input filtering.

Input filtering is complicated by the fact that the mismatch between added resistance of the filter

resistors and the associated resistance can adversely affect gain, CMR, and offset voltage, V_{OS}. The effect on V_{OS} is partly due to input bias currents as well. As a result, the value of the input resistors should be limited to 100Ω or less.

Total Error Analysis

To optimize the design, the first is to analyze each error contributed; the main influences of sense voltage errors can be identified as follows :

- The tolerance of shunt resistor (R_{SHUNT})
- Sense offset voltage, V_{OS}. When the sense voltage is small, especially low load current and small shunt resistance, the error is dominated by the input offset error.
- Gain Error, GE%
- PSR of offset voltage, PSR
- Common mode rejection, CMR
- The offset voltage caused by input bias current
- Nonlinearity Error, NLIN%

Max Output Error Estimation

Here is an example. The system bus voltage V_{CM_SYS} connects to V_{IN+} = 18V, system supply voltage V_{CC_SYS} = 5V, shunt resistor accuracy is 1%, 10mΩ 1.5W, the load current is 10A. To set the design goals, the maximum output voltage errors are calculated in the following sections.

Input Offset Voltage Error

The rate of offset error in the total error can be estimated directly from the specification table. The input offset voltage is 2.5mV at T_A = 25°C, the error due to offset can be obtained by the equation below :

$$V_{OS_err} = \frac{V_{OS(max)}}{V_{SENSE}} \times 100\% = \frac{2.5mV}{10m\Omega \times 10A} \times 100\% = 2.5\%$$

Shunt Voltage Gain Error

From the electrical characteristics, the max gain error is 1%

PSR Error

The PSR error is to estimate the error caused by different supply voltage, the RTQ6050/RTQ6052 device specification gives the specified power supply voltage for the input offset voltage specification as $V_{CC_DS} = 2.9V$, when the system supply voltage is not exactly 2.9V may result in an additional error. RTQ6050/RTQ6052 device gives the maximum PSR as $100\mu V/V$. Calculate the PSR error by the equation below :

$$\begin{aligned} \text{PSR}_{err} &= \frac{|V_{CC_DS} - V_{CC_SYS}| \times \text{PSR}}{V_{SENSE}} \times 100\% \\ &= \frac{|2.9 - 5| \times 100 \frac{\mu V}{V}}{10m\Omega \times 10A} \times 100\% = 0.21\% \end{aligned}$$

CMR Error

The CMR error means the input offset error is influenced by the variation of common-mode voltage. In real conditions, calculate the maximum input offset by determining the actual common-mode voltage as applied to RTQ6050/RTQ6052. According to the RTQ6050/RTQ6052 device specification, it gives the common-mode rejection ratio minimum as 80dB ($100\mu V/V$). The offset voltage in the data sheet is specified with a common-mode voltage, V_{CM_DS} that is 12V. To calculate the actual common-mode error at system bus voltage :

$$80\text{dB} = \frac{1}{10^{\left(\frac{80\text{dB}}{20}\right)}} \times 10^6 \times \frac{\mu V}{V} = 100 \frac{\mu V}{V}$$

$$\begin{aligned} \text{CMR}_{err} &= \frac{|V_{CM_DS} - V_{CM_SYS}| \times \text{CMR}}{V_{SENSE}} \times 100\% \\ &= \frac{|12 - 18| \times 100 \frac{\mu V}{V}}{10m\Omega \times 10A} \times 100\% = 0.6\% \end{aligned}$$

Input Bias Current Error

The input bias current flows into shunt resistor to cause additional offset; this error is calculated with respect to the ideal voltage across the sense voltage.

$$\begin{aligned} I_{B_err} &= \frac{I_B \times R_{SHUNT}}{V_{SENSE}} \times 100\% = \frac{13\mu A \times 10m\Omega}{10m\Omega \times 10A} \times 100\% \\ &= 0.00013\% \end{aligned}$$

Nonlinearity Error

The nonlinearity error shown in Figure 3 is the difference between an actual gain and the ideal value. For ideal cases, the voltage gain is constant over full sense ranges, but in the real application, the voltage gain is not exactly constant, the nonlinearity gain may cause additional errors. In the specification, the RTQ6050/RTQ6052 gives the nonlinearity error as 0.1% over sense voltage from 20mV to 100mV.

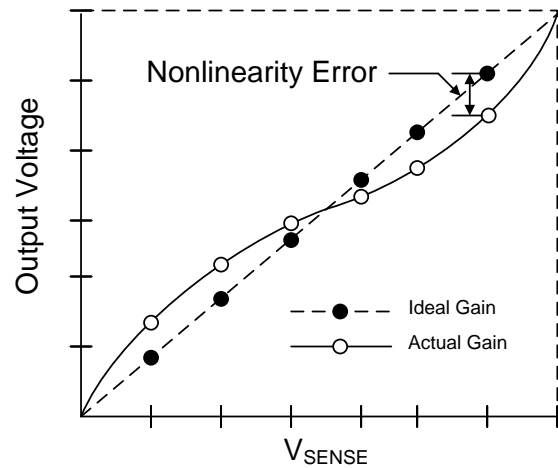

Figure 3. Nonlinearity Error

Total Error

Use equation below to calculate the worst case of total error :

$$\begin{aligned} \text{Total_err} &= \sqrt{(\text{GE}\%)^2 + (\text{R}\%)^2 + (\text{V}_{\text{OS_err}})^2 + (\text{PSR_err})^2 + (\text{CMR_err})^2 + (\text{I}_{\text{B_err}})^2 + (\text{NLIN}\%)^2} \\ &= \sqrt{(1\%)^2 + (1\%)^2 + (2.5\%)^2 + (0.21\%)^2 + (0.6\%)^2 + (0.0013\%)^2 + (0.1\%)^2} \\ &= 2.94\% \end{aligned}$$

Layout Guidelines

- ▶ A Kelvin sense arrangement is required for best performance. Connect the input pins (VIN+ and VIN-) to the sensing resistor using a 4-wire connection.
- ▶ PCB trace resistance from the sense resistor to the VIN+ and VIN- pins can affect the power measurement accuracy. Place the sense resistors as close as possible to the RTQ6050/RTQ6052 and do not use minimum width PCB traces.
- ▶ Place the power-supply bypass capacitor 0.1 μF as close as possible to the supply and ground pins.

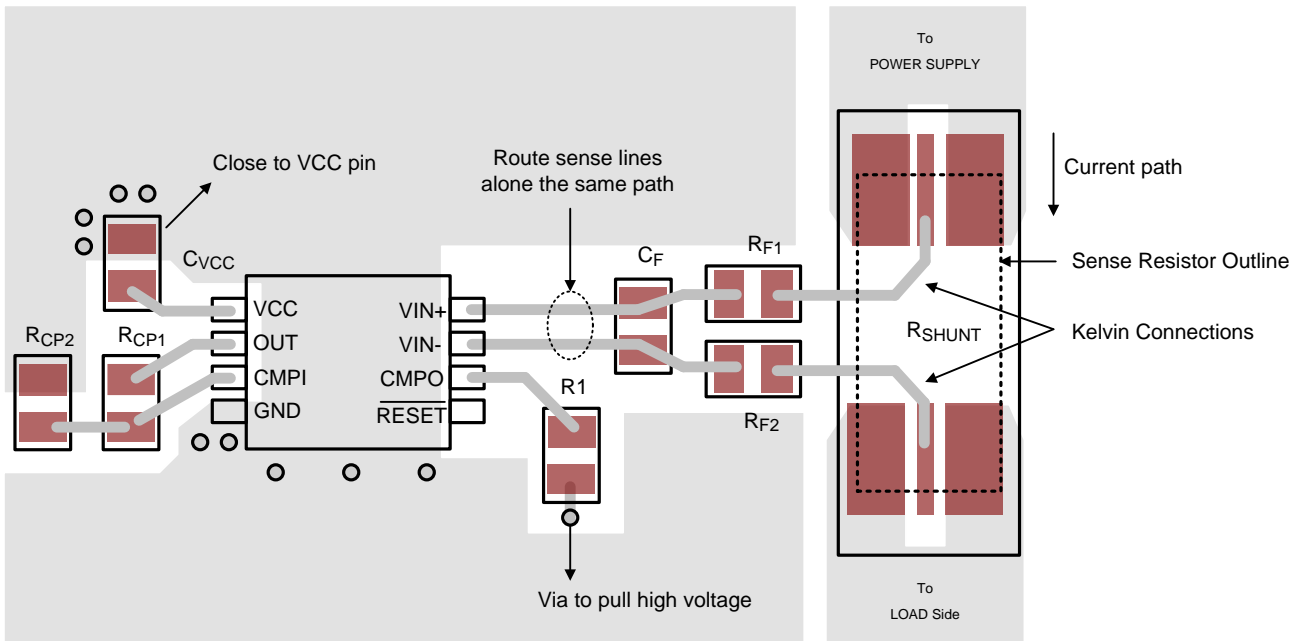
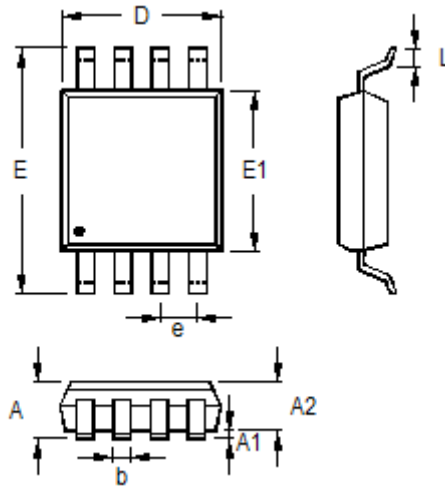

Figure 4. PCB Layout Guide

Outline Dimension



Symbol	Dimensions In Millimeters		Dimensions In Inches	
	Min	Max	Min	Max
A	0.810	1.100	0.032	0.043
A1	0.000	0.150	0.000	0.006
A2	0.750	0.950	0.030	0.037
b	0.220	0.380	0.009	0.015
D	2.900	3.100	0.114	0.122
e	0.650		0.026	
E	4.800	5.000	0.189	0.197
E1	2.900	3.100	0.114	0.122
L	0.400	0.800	0.016	0.031

8-Lead MSOP Plastic Package

Footprint Information

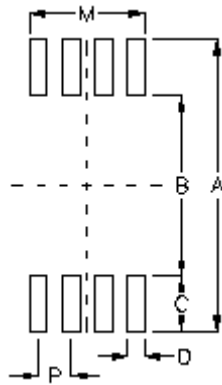

Package	Number of Pin	Footprint Dimension (mm)						Tolerance
		P	A	B	C	D	M	
MSOP-8	8	0.65	5.80	3.60	1.10	0.35	2.30	±0.10

Packing Information

Tape and Reel Data

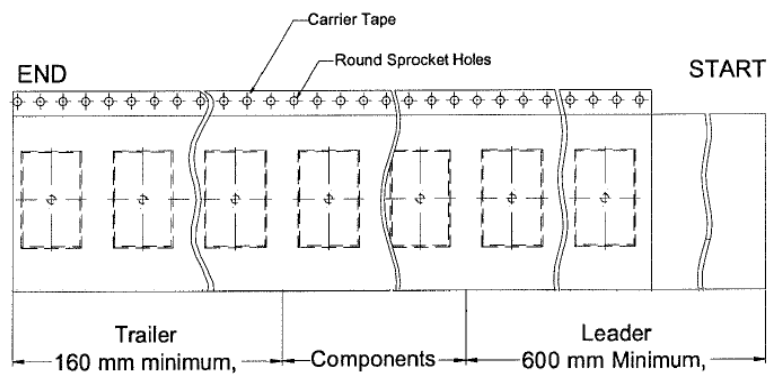
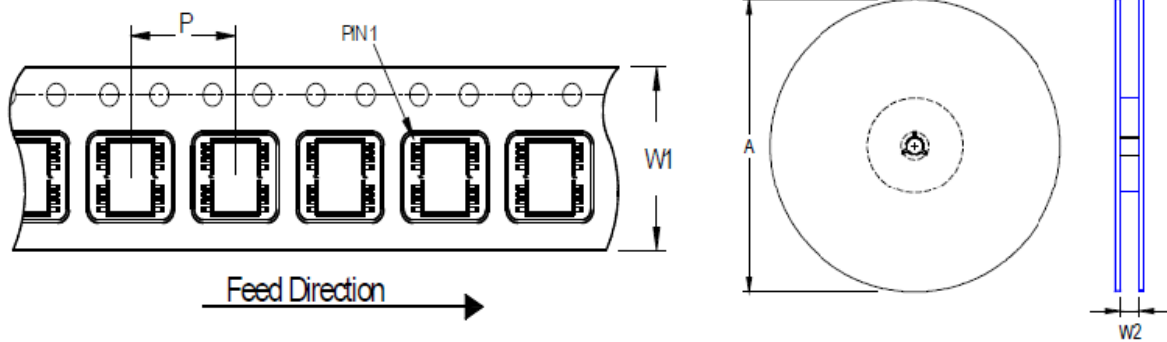



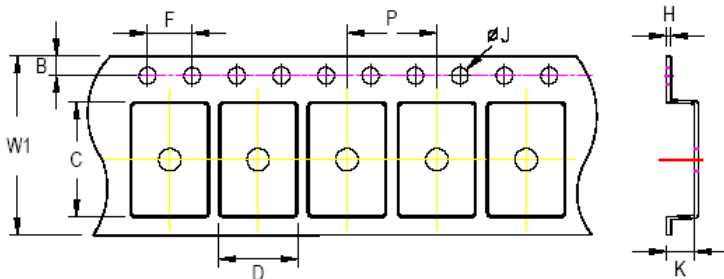



Package Type	Tape Size (W1) (mm)	Pocket Pitch (P) (mm)	Reel Size (A)		Units per Reel	Trailer (mm)	Leader (mm)	Reel Width (W2) Min./Max. (mm)
			(mm)	(in)				
SOP-8	12	8	330	13	2,500	160	600	12.4/14.4



C, D and K are determined by component size.
The clearance between the components and the cavity is as follows:
- For 12mm carrier tape: 1.0mm max.

Tape Size	W1		P		B		F		ØJ		H
	Max.	Min.	Max.	Min.	Max.	Min.	Max.	Min.	Max.	Max.	
12mm	12.3mm	7.9mm	8.1mm	1.65mm	1.85mm	3.9mm	4.1mm	1.5mm	1.6mm	0.6mm	

Tape and Reel Packing

Step	Photo / Description	Step	Photo / Description
1	 <p>Reel 13"</p>	4	 <p>1 reel per inner box Box G</p>
2	 <p>HIC & Desiccant (2 Unit) inside</p>	5	 <p>6 inner boxes per outer box</p>
3	 <p>Caution label is on backside of Al bag</p>	6	 <p>Outer box Carton A</p>

Package \ Container	Reel		Box			Carton		
	Size	Units	Item	Reels	Units	Item	Boxes	Units
SOP-8	13"	2,500	Box G	1	2,500	Carton A	6	15,000

Packing Material Anti-ESD Property

Surface Resistance	Aluminum Bag	Reel	Cover tape	Carrier tape	Tube	Protection Band
Ω/cm^2	$10^4 \sim 10^{11}$	$10^4 \sim 10^{11}$	$10^4 \sim 10^{11}$	$10^4 \sim 10^{11}$	$10^4 \sim 10^{11}$	$10^4 \sim 10^{11}$

Richtek Technology Corporation

14F, No. 8, Tai Yuen 1st Street, Chupei City

Hsinchu, Taiwan, R.O.C.

Tel: (8863)5526789

Richtek products are sold by description only. Richtek reserves the right to change the circuitry and/or specifications without notice at any time. Customers should obtain the latest relevant information and data sheets before placing orders and should verify that such information is current and complete. Richtek cannot assume responsibility for use of any circuitry other than circuitry entirely embodied in a Richtek product. Information furnished by Richtek is believed to be accurate and reliable. However, no responsibility is assumed by Richtek or its subsidiaries for its use; nor for any infringements of patents or other rights of third parties which may result from its use. No license is granted by implication or otherwise under any patent or patent rights of Richtek or its subsidiaries.

Copyright © 2022 Richtek Technology Corporation. All rights reserved. is a registered trademark of Richtek Technology Corporation.

www.richtek.com

DSQ6050/DSQ6052-01 November 2022