

CUSTOMER'S NAME

MOUSER ELECTRONICS

ALPHA REFERENCE NO.

SP16040218



SPECIFICATION

PART NO.	ALPHA MODEL NAME
	RV122F-20-15F-BXXK-0072
	BXXK for (B1~500K)

MODEL NAME

MODEL NO.

APPROVAL

PREPARED BY	REVIEWED BY	APPROVED BY
 2016.4.29 彩霞		 2016-4-29 延珍



台灣艾華電子工業股份有限公司

33045 桃園市桃園區中正路 1221 號 9 樓

TAIWAN ALPHA ELECTRONIC CO., LTD.

9F, No. 1221, Chung Cheng Rd., Taoyuan Dist., Taoyuan City, 330 Taiwan

Tel: 886-3-3577799 Fax: 886-3-3577700

EMAIL: sales@taiwanalpha.com.tw

URL: http://www.taiwanalpha.com

石碇福隆工業區艾華電子
 JUN 10, 2008
 收文日



SHAFT SHOWN IN FULL C.C.W. POSITION

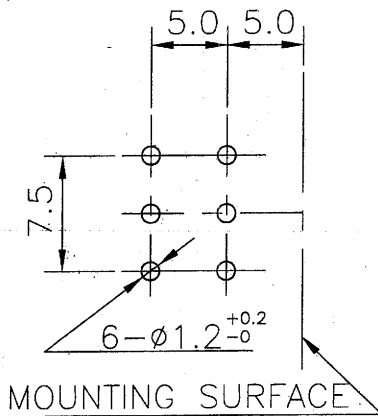
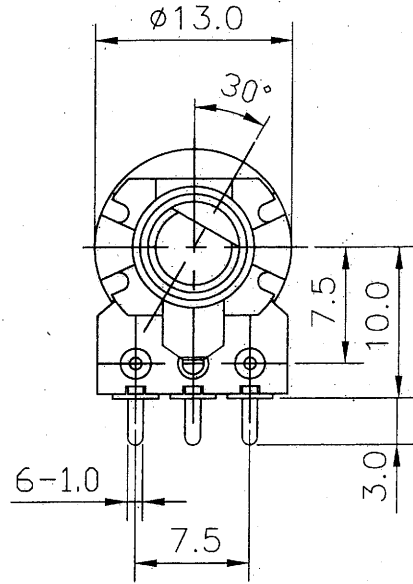
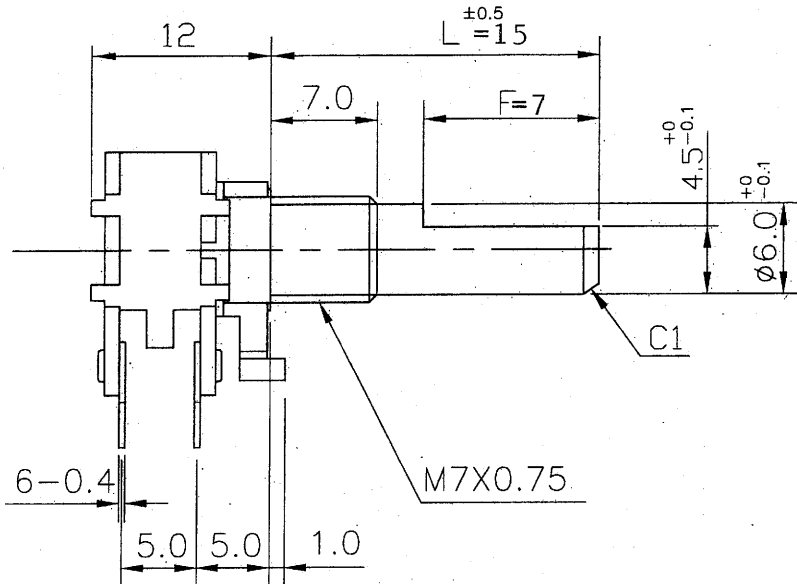

P.C.B. MOUNTING HOLE DETAIL

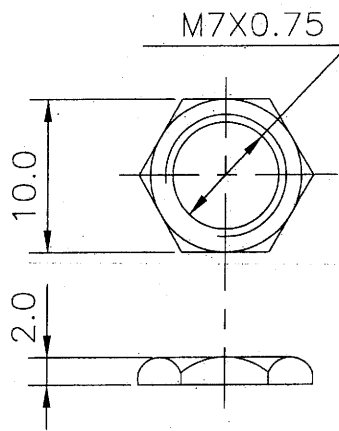

NUT 1PC

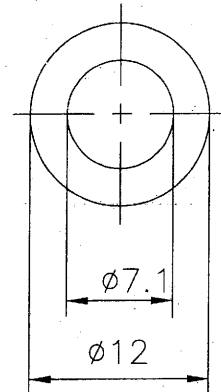

WASHER 1PC



				-0072			
				RV122F-20-(L)F-XXX			
No.	DATE	DESCRIPTION	PART No.	NAME			
TOL. UNLESS OTHERWISE STATED		DIMENSION	SCALE	DRAWN BY	CHECKED BY	APPROVED BY	DRAWING No.
less than	10	±0.3	2 1				
above	10~30	±0.5					
above	30~100	±1.0					
above		±5'					

12Ø 單軸多連迴轉型規格書

SPECIFICATIONS OF ROTARY POTENTIOMETER

一、電氣規格：

Electrical characteristics :

1.1 全阻值：阻值適用範圍：1 KΩ- 500 KΩ (容許差±20%)

Overall resistance range : 1 KΩ- 500 KΩ (Tolerance±20%)

1.2 額定功率：B特性 0.08W B特性以外 0.04W

Power rating : B Taper 0.08W Except B Taper 0.04W

1.3 阻抗變化特性 Taper :

阻抗變化 特性 Taper	測定角度 Test point	端子 1-2 間輸出電壓	V1-2	端子 2-3 間輸出電壓	V2-3
		端子 1-3 間輸入電壓	V1-3 (%)	端子 1-3 間輸入電壓	V1-3 (%)
A	150°	10-25			
B	150°	40-60			
C	150°			10-25	
D(10A)	150°	6-15			
X(10C)	150°			6-15	
K(25A)	150°	18-34			
E(25C)	150°			18-34	

1.4 殘留阻值：1-2 端子/2-3 端子同·

Residual resistance : 1-2/2-3 Same

公稱阻抗值(KΩ) Overall resistance(KΩ)	殘留阻值 (Ω) Residual resistance(Ω)	
$R \leq 10$	10 以下	10MAX
$10 < R \leq 250$	20 以下	20MAX
$250 < R \leq 500$	全阻值的 0.1% 以下 0.1% Max of total resistance	

1.5 轉動雜音：依 JIS 測定法 47mV 以下·

Rotation noise (Refer to JIS) : 47mV max.

1.6 絕緣阻抗：D.C 500V 主軸與端子絕緣阻抗須在 50MΩ 以上·

Insulation resistance : 50MΩ min. at D.C 500V between shaft and terminal.

1.7 耐電壓：A.C 500V 可耐 1 分鐘以上，軸與接頭之間不得有損傷或絕緣破壞之現象發生·

Dielectric test : Units shall be designed to withstand 500 volts between resistance elements and case for a period of one minute without damage or arcing.

1.8 最高使用電壓：A.C 100V. (A.C 專用)·

Maximum operating voltage : 100V A.C (A.C voltage only)

1.9 連動誤差：在前、後段的 1-3 端子間加 1KHZ, 2V 的電壓，以前段為基準,1-2 端子間的輸出測定

前段

-40~0dB 之間

後段誤差

在 ±3dB 以內

Tracking error : Apply 2V (1KHZ) across terminals 1 and 3 of the front and rear sections measure the output level across terminals 1 and 2 of the outer section is within 3dB of the inner section output level which is -40 to 0 dB.

12Ø 單軸多連迴轉型規格書

SPECIFICATIONS OF ROTARY POTENTIOMETER

二、機械規格：

Mechanical :

2.1 全迴轉角度：300±5度

Total rotation angle : 300±5°

2.2 回轉轉矩：20~250gf-cm (迴轉速度 60度 / 1秒)

Rotation torque : 20~250gf-cm. (Rotational speed 60° / 1 sec)

2.3 軸鬆動：固定腳銲錫後軸前端加上 250gf-cm 之力矩，於軸前端移動 0.8
xL/20mm P-P 以內。

Play of shaft : The resistor shall be mounted by soldering the mounting legs on the panel, and an end thrust of 250gf-cm at the end of the shaft shall be applied. Then the total play of the shaft shall not exceed 0.8xL/20mm P-P.

2.4 軸擠壓引張強度：在軸之方向加壓力或張力之靜負荷 10kgf, 10 秒鐘無異常。

Axis push-pull strength : No damages with an application of push or pull force 10kgf for 10 sec.

2.5 軸之迴轉止動強度：3kgf-cm 以上。

Shaft end stop strength : 3kgf-cm min.

2.6 軸承螺絲固定強度：7kgf-cm 以上。

Bushing mount strength : 7kgf-cm min.

2.7 端子強度：銲錫後, 不可發生顯著之鬆動接觸不良。

Resistance to soldering heat : After soldering, there shall be no evidence of poor contact between resistance element and terminals, or any physical damages as a result of the test.

2.8 CLICK 位置：150 ± 2.5°

POSITION OF CLICK : 150 ± 2.5°

2.9 CLICK 脫出力：50~300gf-cm

TORQUE OF CLICK : 50~300gf-cm

☆ (2.8, 2.9 僅適用於附 CLICK 時)

(2.8, 2.9 IS USED FOR CLICK ONLY)

三、耐久性：

Reliability test :

3.1 電阻體迴轉壽命特性：15,000 轉以上，壽命試驗後 200mV 以下。

Rotational life : 15,000 cycles min. After life test : 200mV max.

* (500Ω resistance shall be endurable with life test of more than 5,000 cycles.)

四、其它 NOTE

4.1 依照 J I S C - 6 4 4 3 普通級碳素系可變電阻器。

Meet or exceed J I S C - 6 4 4 3 Requirements.

STANDARD RESISTANCE TAPER

3B TAPER (VOL.CONTROL) (ALPHA:P)

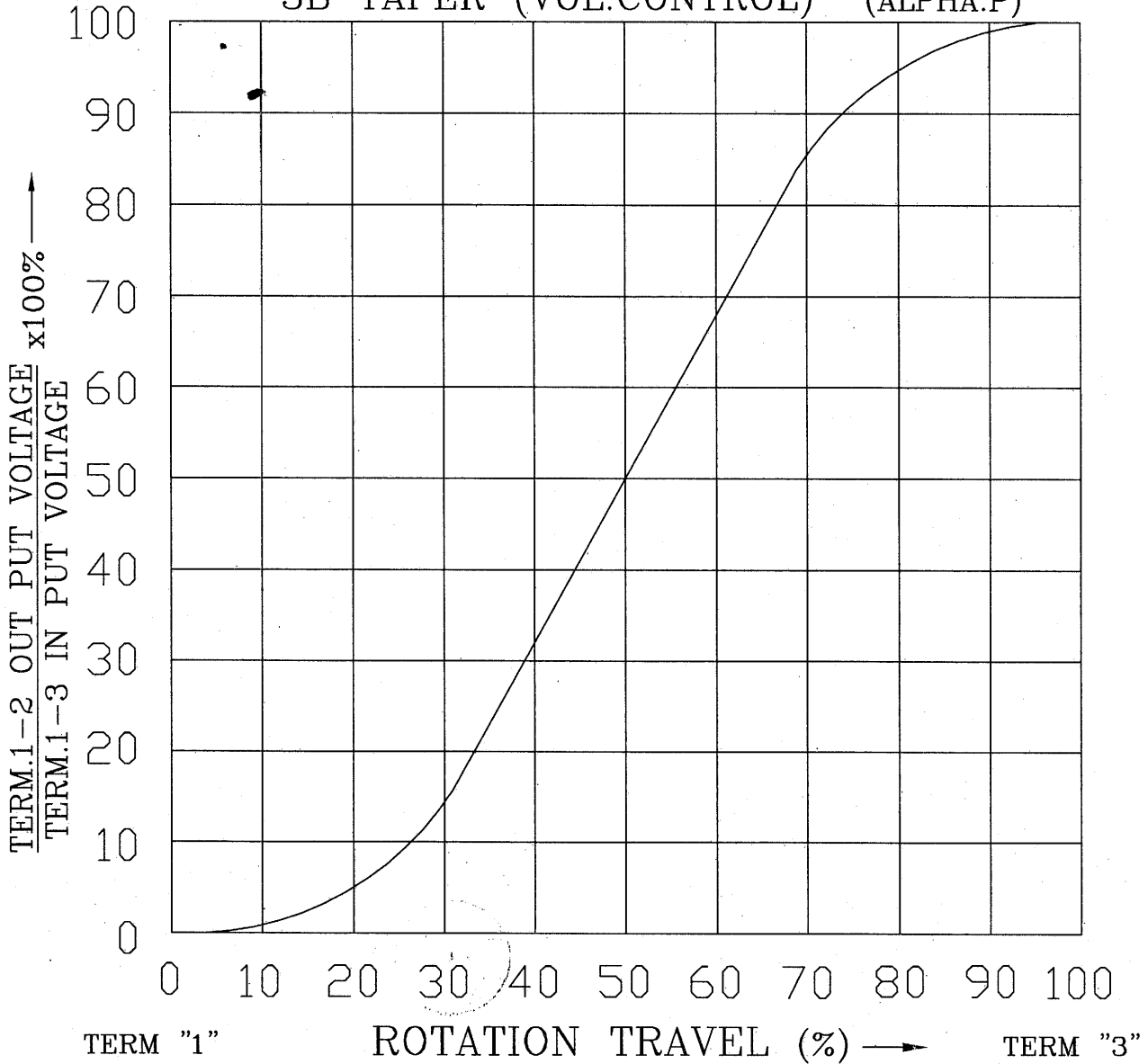

NO.	DATE	DESCRIPTION	MODEL NAME			
TOL. UNLESS OTHERWISE STATED	DIMENSION	SCALE	DRAWN BY	CHECKED BY	APPROVED BY	DRAWING NO.
less than 10 ±0.3	mm		何	王	王	
above 10 ~ 30 ±0.5			90.8.21	90.8.21	90.8.21	
above 30 ~ 100 ±1.0			建志	茂松	茂松	
above ±5°						