

CUSTOMER'S NAME

MOUSER ELECTRONICS

ALPHA REFERENCE NO.

SP19070100

SPECIFICATION

PART NO.	ALPHA MODEL NAME
	RV170SF-10-15R1-B1K-0021
	31CQ301-F

MODEL NAME
MODEL NO.

APPROVAL

PREPARED BY	REVIEWED BY	APPROVED BY
 2019.7.13 鄧彩霞	 2019-7-13 李延玲	 2019.7.15 張祖衛



台灣艾華電子工業股份有限公司

33045 桃園市桃園區中正路 1221 號 9 樓

TAIWAN ALPHA ELECTRONIC CO., LTD.

9F, No. 1221, Chung Cheng Rd., Taoyuan Dist., Taoyuan City, 330 Taiwan

Tel: 886-3-3577799 Fax: 886-3-3577700

EMAIL: sales@taiwanalpha.com.tw

URL: http://www.taiwanalpha.com

文管中心
2016.06.27
發行章

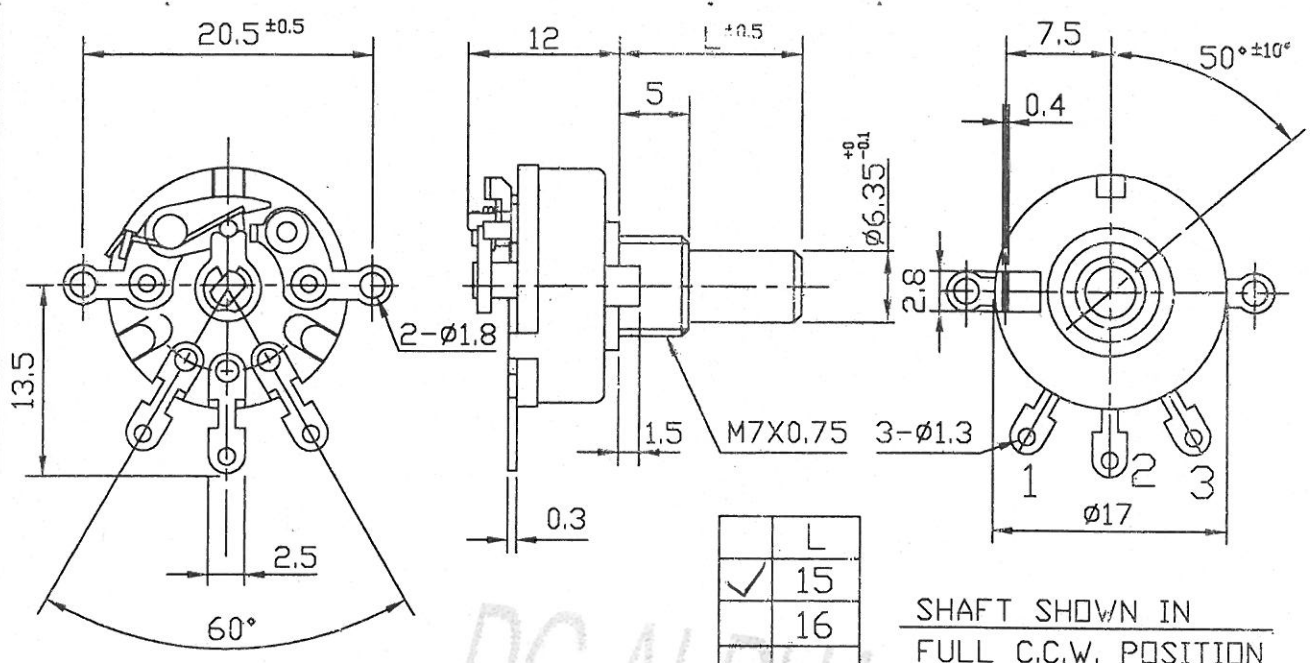

SHAFT SHOWN IN FULL C.C.W. POSITION

NUT 1 PC

WASHER 1 PC

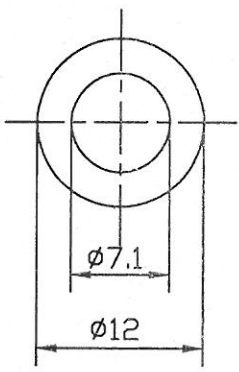
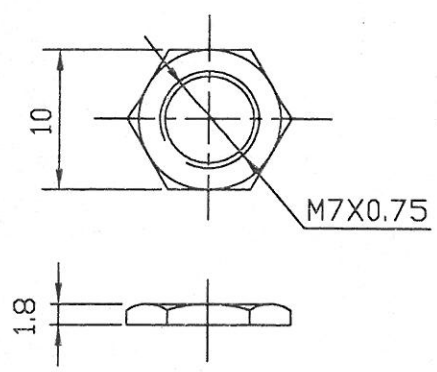

● 260° ROTATION MONO UNIT

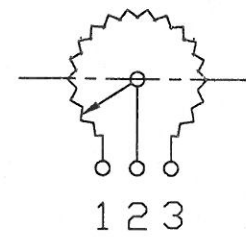

CIRCUIT

2016-07-06
收文

(-0021)

RV170SF-10-(L)R1-XXX(-0030)

NO.	DATE	DESCRIPTION	MODEL NAME			
TOL. UNLESS OTHERWISE STATED	DIMENSION	SCALE	DRAWN BY	CHECKED BY	APPROVED BY	DRAWING NO.
less than 10 ±0.3	mm	2	姚 2016.6.21 榕偉		潘 2016.6.24 坤	
above 10 ~ 30 ±0.5						
above 30 ~ 100 ±1.0						
above ±5'						

CUSTOMER'S NAME	NOTE	DATE
CUSTOMER'S PART NAME		
CUSTOMER'S DRAWING NO.		

1. MECHANICAL SPECIFICATION		2. ELECTRICAL SPECIFICATION	
1. OUTSIDE DIMENSION	append fig.	terminal 1-3	1K $\Omega \pm 20\%$
2. TOTAL ROTATION ANGLE	degree	terminal 1-4	$\Omega \pm$
3. TOTAL TRAVEL STROKE	mm	temp 0~50°C	0.1 W
4. NUT WIRING STRENGTH	twisting moment		200 V
5. SCREW TIGHTENING FORCE	torsional moment		50 %point
6. ROTATION TORQUE	speed 60 deg/sec.		40 ~ 60 %
7. SLIDING FORCE	speed 20mm/sec		less than 10/20 Ω
8. SHAFT LEVER STRENGTH	pulling pushing	terminal 1/3 side	less than 100 Ω
9. SHAFT LEVER WOBBLE	within mm (bending moment)	terminal 4 side	less than 47 mV
10. SHAFT LEVER STOP STRENGTH	more than 3 kgf.cm (static load) / more than 500 gf.cm / 10 ± 1 sec	more than 50 M Ω (DC)	500 V)
11. TERMINAL STRENGTH	soldering heat 350 ± 5 °C/3sec. 200gf.cm/10 ± 1 sec resist change within $\pm 2\%$	AC 500 V	1 minute
12. CLICK POSITION & TORQUE	gf.cm	M Ω	less than 50 m Ω
13. SWITCH WORKING ANGLE (STROKE)	degree (mm)		12V DC , 1A
14. SWITCH WORKING TORQUE (FORCE)	gf.cm		
15. SWITCH CIRCUIT	S.P.S.T		

3. USABLE TEMPERATURE RANGE: from -10°C to 70°C

4. VR LIFE 15,000 \pm TIMES

RESISTANCE CHANGE: within \pm %

SLIDE NOISE : less than mV

SW LIFE 10,000 \pm TIMES

CONTACT RESISTANCE: less than m Ω

SHAFT

ANGLE OF FLAT OR SLOT	DIMENSION		
MATERIAL θ	M	L	F
at		15	T

MODEL NAME	DRAWING NO.
RV170SF-10-15R1-B1K-0021	

REFERENCE NO.	REV

STANDARD RESISTANCE TAPER

B TAPER (JIS:B)

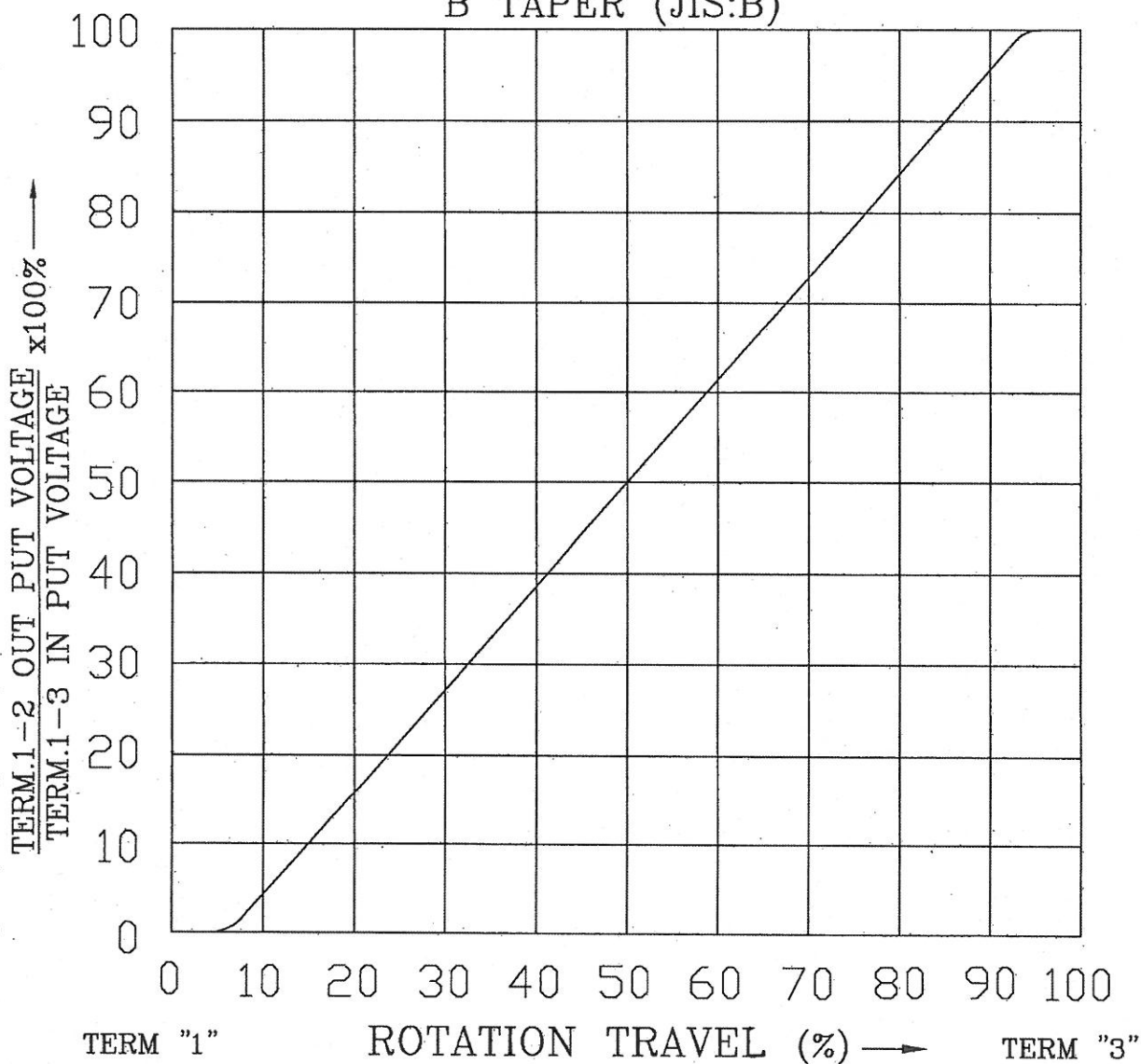

NO.	DATE	DESCRIPTION	MODEL NAME			
TOL. UNLESS OTHERWISE STATED	DIMENSION	SCALE	DRAWN BY	CHECKED BY	APPROVED BY	DRAWING NO.
less than 10 ±0.3			何 90.8.21 建志	王 90.8.21 茂松	王 90.8.21 茂松	
above 10 ~ 30 ±0.5						
above 30 ~ 100 ±1.0	mm					
above ±5°						