

CUSTOMER'S NAME

MOUSER ELECTRONICS

ALPHA REFERENCE NO.



SP16090085

# SPECIFICATION

PART NO.	ALPHA MODEL NAME
	RV170SF-10-15R1-BXXK-0021
	BXXK for (B1~500K)

MODEL NAME
MODEL NO.

APPROVAL

PREPARED BY	REVIEWED BY	APPROVED BY
 2016.9.12 彩霞		 2016-9-12 延珍



台灣艾華電子工業股份有限公司

33045 桃園市桃園區中正路 1221 號 9 樓

TAIWAN ALPHA ELECTRONIC CO., LTD.

9F, No. 1221, Chung Cheng Rd., Taoyuan Dist., Taoyuan City, 330 Taiwan

Tel: 886-3-3577799 Fax: 886-3-3577700

EMAIL: sales@taiwanalpha.com.tw

URL: http://www.taiwanalpha.com

文管中心  
2016.06.27  
發行章

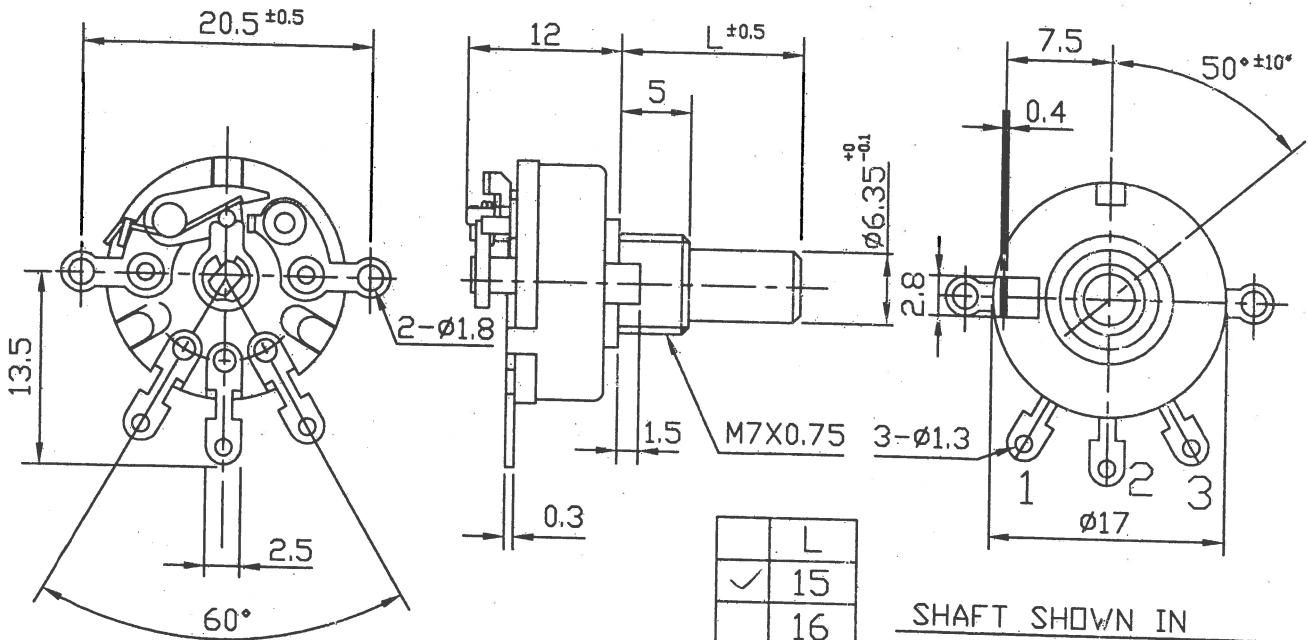

	L
✓	15
	16

SHAFT SHOWN IN  
FULL C.C.W. POSITION

NUT 1 PC

WASHER 1 PC

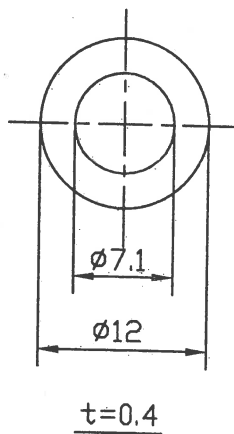
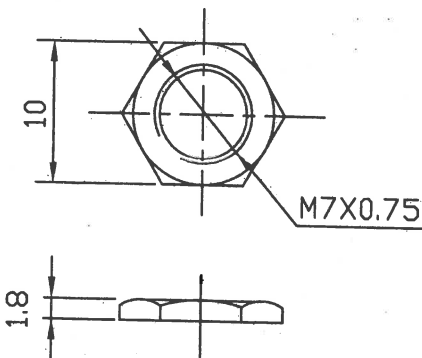

● 260° ROTATION  
MONO UNIT

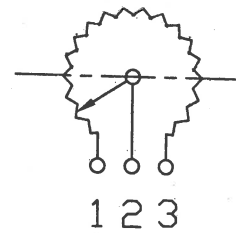

CIRCUIT

東莞艾華電子有限公司  
2016-07-06  
收文日

(-0021)

RV170SF-10-(L)R1-XXX(-0030)

NO. DATE

DESCRIPTION

MODEL NAME

TOL. UNLESS OTHERWISE STATED

DIMENSION

SCALE

DRAWN BY

CHECKED BY

APPROVED BY

DRAWING NO.

less than	10	±0.3
above	10 ~ 30	±0.5
above	30 ~ 100	±1.0
above		±5°

mm

2

1

姚  
2016.6.21  
榕偉

潘  
2016.6.24  
坤

CUSTOMER'S NAME	NOTE	DATE
CUSTOMER'S PART NAME		
CUSTOMER'S DRAWING NO.		

### 1. MECHANICAL SPECIFICATION

1. OUTSIDE DIMENSION	append fig.	
2. TOTAL ROTATION ANGLE	degree	260 ±5°
3. TOTAL TRAVEL STROKE	mm	±0.5
4. NUT WIRING STRENGTH	twisting moment	less than 7 kgf.cm
5. SCREW TIGHTENING FORCE	torsional moment	less than kgf.cm
6. ROTATION TORQUE	speed 60 deg/sec.	20~200 gf.cm
7. SLIDING FORCE	speed 20mm/sec	gf.cm
8. SHAFT LEVER STRENGTH	pulling pushing	more than kgf.cm
9. SHAFT LEVER WOBBLE	within mm (bending moment)	gf.cm
10. SHAFT LEVER STOP STRENGTH	more than 3 kgf.cm (static load) / more than 500 gf.cm / 10 ± 1 sec	60 sec
11. TERMINAL STRENGTH	soldering heat 350±5°C/3sec. 200gf.cm/10 ±1sec resist change within ± 2%	
12. CLICK POSITION & TORQUE	gf.cm	
13. SWITCH WORKING ANGLE (STROKE)	degree (mm)	30°±10°
14. SWITCH WORKING TORQUE (FORCE)	gf.cm	70-400gf.cm
15. SWITCH CIRCUIT		S.P.S.T

### 2. ELECTRICAL SPECIFICATION

1. OVERALL RESISTANCE & TOLERANCE	terminal 1-3	1~500K Ω±	20 %
2. TAP RESISTANCE & TOLERANCE	terminal 1-4	Ω±	%
3. RATED WATTAGE	temp 0~50°C	0.1	W
4. MAXIMUM WORKING VOLTAGE		200	V
5. RESISTANCE TAPER MEASURING POINT & TOLERANCE		50	%point
6. RESIDUAL RESISTANCE	terminal 1/3 side	less than	20/30 Ω
7. TAP RESIDUAL RESISTANCE	terminal 4 side	less than	100 Ω
8. SLIDE NOISE		less than	47 mV
9. INSULATION RESISTANCE	more than 50	MΩ(DC)	500 V)
10. WITHSTAND VOLTAGE	AC 500	V	1 minute
11. TRACKING ERROR			
12. SWITCH CONTACT RESISTANCE	MΩ		less than 50 mΩ
13. SWITCH RATING		12V DC	, 1A

### 3. USABLE TEMPERATURE RANGE: from -10°C to 70°C

4. VR LIFE 15,000 ± TIMES

RESISTANCE CHANGE: within ± %

SLIDE NOISE : less than mV

SW LIFE 10,000 ± TIMES

CONTACT RESISTANCE: less than mΩ

### SHAFT

MATERIAL	ANGLE OF FLAT OR SLOT θ	DIMENSION		
		M	L	F
	at		15	T

MODEL NAME	DRAWING NO.
RV170SF-10-15R1-B1~500K-0021	

REFERENCE NO.

REV

# STANDARD RESISTANCE TAPER

## B TAPER (JIS:B)

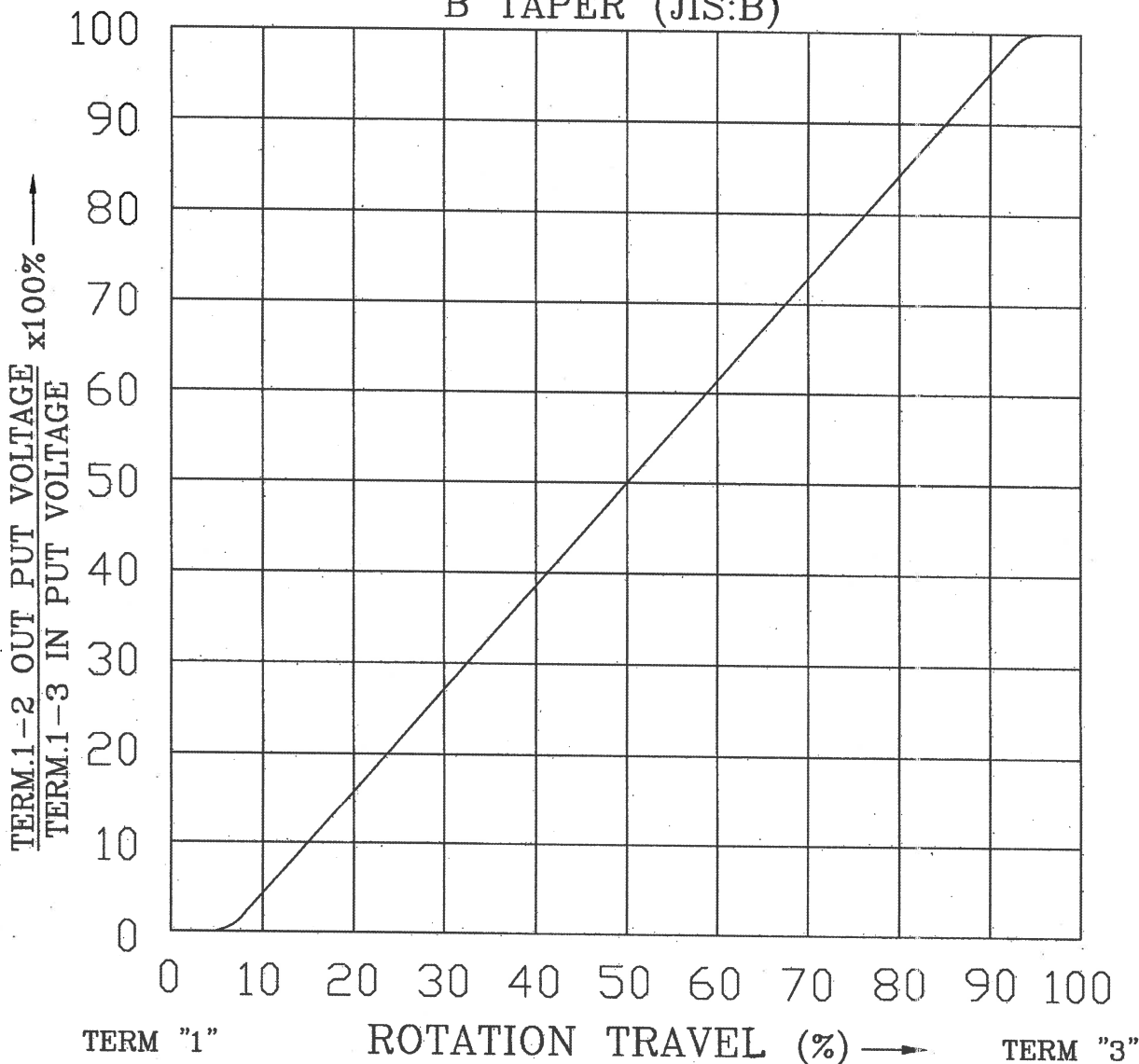

NO.	DATE	DESCRIPTION			MODEL NAME		
TOL. UNLESS OTHERWISE STATED	DIMENSION	SCALE	DRAWN BY	CHECKED BY	APPROVED BY	DRAWING NO.	
less than 10 ±0.3	mm		何 90.8.21 建志	王 90.8.21 茂松	王 90.8.21 茂松		
above 10 ~ 30 ±0.5							
above 30 ~ 100 ±1.0							
above ±5°							