

# RV1S2211A

R08DS0184EJ0100

OPERATING AMBIENT TEMPERATURE 115°C, LOW FORWARD-CURRENT(IF),  
4-PIN SSOP WITH 8.2mm CREEPAGE DISTANCE (LSSOP) PHOTOCOUPLER

Rev.1.00  
Nov 11,2019

## DESCRIPTION

The RV1S2211A is an optically coupled isolator containing a GaAs light emitting diode and an NPN silicon phototransistor.

This package is very small and thin with long creepage distance(8.2mm).

This small product is suitable for various interface circuits which require surface mounting and high-density mounting.

## FEATURES

- Small and long creepage (8.2 mm, LSSOP)
- High current transfer ratio (CTR = 200% TYP. @ IF = 1 mA)
- Operating ambient temperature: 115°C
- High isolation voltage (BV = 5000 Vr.m.s.)
- Embossed tape product : RV1S2211ACCSP-10Yx#KC0 : 3500 pcs/reel
- Pb-Free product
- Safety standard
  - UL : UL1577, Double protection
  - CSA : CAN/CSA-C22.2 No.62368-1, Reinforced insulation
  - VDE : DIN EN 60747-5-5 (Option)

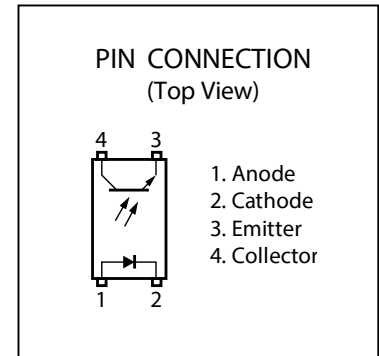

## APPLICATIONS

- Robot controller
- Industrial inverter
- AC Servo
- Programmable logic controller
- Measurement equipment
- Power supply

Start of mass production  
Nov.2019

PACKAGE DIMENSIONS (UNIT : mm)

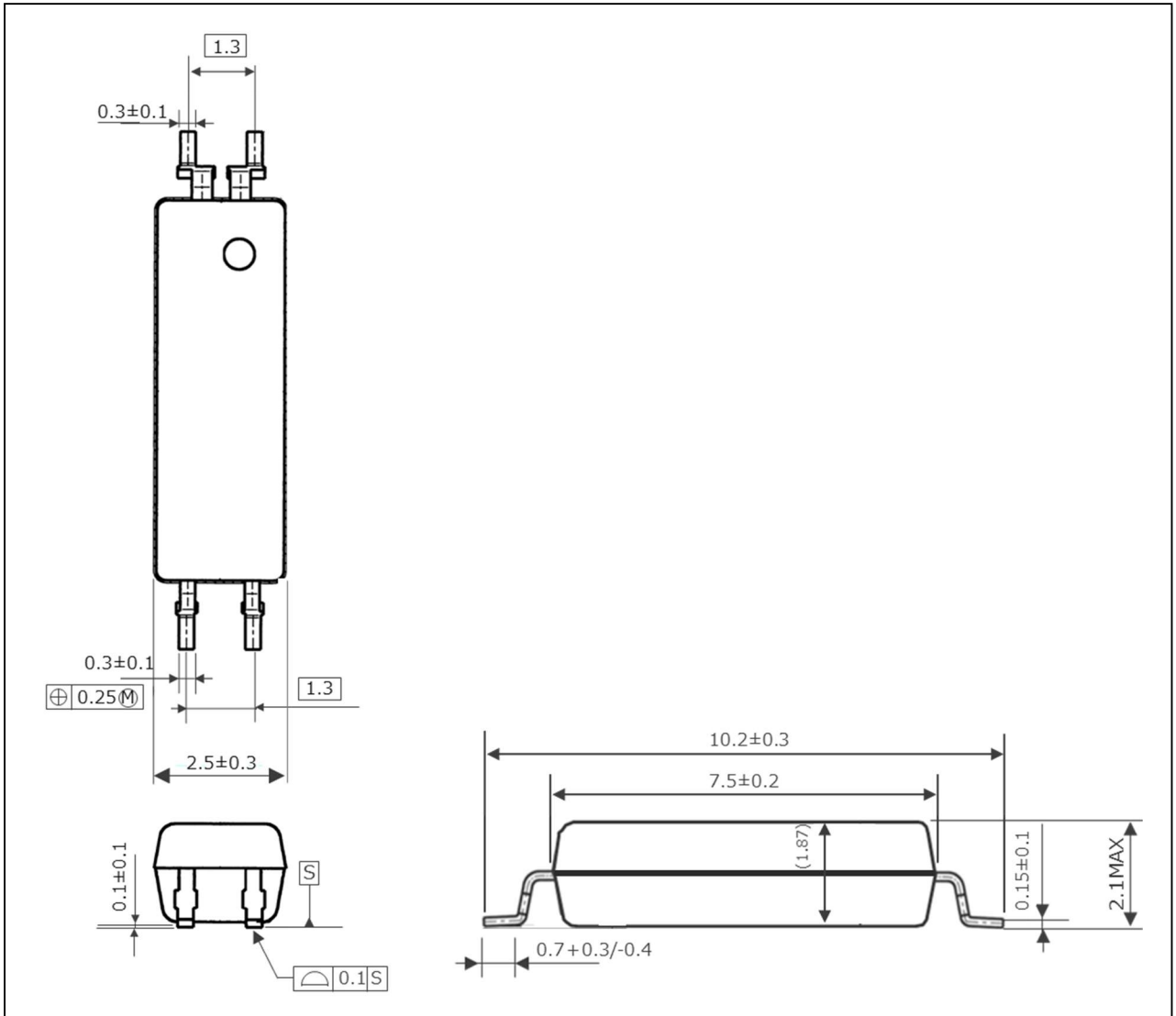

Weight : 0.075g (Typ.)

PHOTOCOUPLER CONSTRUCTIONS

Parameter	UNIT (MIN.)
Air Distance	8.2 mm
Creepage Distance	8.2 mm
Isolation Distance	0.15 mm

## MARKING EXAMPLE

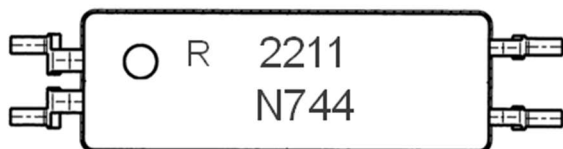

R		An initial of "Renesas"	
2211		Product Part Number *	
O		No.1 pin Mark	
N744	N	Rank Code	
	744	Assembly Lot	
		7	Last one-digit of Assembly Year
		44	Weekly Serial Code

\* ) Applicable type numbers listed below

RV1S 2211 ACCSP-10Yx

Marking type number. "RV1S" and "ACCSP-10Yx" are omitted from original type number

## ORDERING INFORMATION

Part Number	Order Number	Solder Plating Specification*1	Packing Style	Safety Standard Approval	Application Part Number*2
RV1S2211ACCSP-10YC	RV1S2211ACCSP-10YC#SC0	Pb-Free and Halogen Free (Ni/Pd/Au)	20 pcs(Tape 20 pcs cut)	Standard products (UL, CSA approved)	RV1S2211A
	RV1S2211ACCSP-10YC#KC0		Embossed Tape 3500 pcs/reel		
RV1S2211ACCSP-10YV	RV1S2211ACCSP-10YV#SC0		20 pcs(Tape 20 pcs cut)	UL, CSA, DIN EN 60747-5-5 approved	
	RV1S2211ACCSP-10YV#KC0		Embossed Tape 3500 pcs/reel		

Notes:\*1. When specifying CTR rank, please add "/CTR rank" after Order Number.

ex. L rank : RV1S2211ACCSP-10YC#SC0/L

Notes:\*2. For the application of the Safety Standard, following part number should be used.

ABSOLUTE MAXIMUM RATINGS (T<sub>A</sub>=25°C, unless otherwise specified)

Parameter		Symbol	Ratings	Unit
Diode	Forward Current (DC)	I <sub>F</sub>	30	mA
	Reverse Voltage	V <sub>R</sub>	6	V
	Power Dissipation Derating*1	ΔP <sub>D</sub> /°C	0.6	mW/°C
	Power Dissipation	P <sub>D</sub>	60	mW
	Peak Forward Current*2	I <sub>FP</sub>	0.5	A
Transistor	Collector to Emitter Voltage	V <sub>CEO</sub>	40	V
	Emitter to Collector Voltage	V <sub>ECO</sub>	5	V
	Collector Current	I <sub>C</sub>	40	mA
	Power Dissipation Derating*1	ΔP <sub>C</sub> /°C	1.2	mW/°C
	Power Dissipation	P <sub>C</sub>	120	mW
Isolation Voltage*3		BV	5000	Vr.m.s.
Operating Ambient Temperature		T <sub>A</sub>	-40 ~ +115	°C
Storage Temperature		T <sub>stg</sub>	-40 ~ +125	°C

\*1 Derating from T<sub>A</sub> = 25°C

\*2 PW = 100 μs, Duty Cycle = 1%

\*3 AC voltage for 1 minute at T<sub>A</sub> = 25°C, RH = 60% between input and output.

Pins 1-2 shorted together, 3-4 shorted together.

ELECTRICAL CHARACTERISTICS (T<sub>A</sub> = 25°C)

Parameter		Symbol	Conditions	MIN.	TYP.	MAX.	Unit
Diode	Forward Voltage	V <sub>F</sub>	I <sub>F</sub> = 5 mA		1.15	1.4	V
	Reverse Current	I <sub>R</sub>	V <sub>R</sub> = 5 V			5	μA
	Terminal Capacitance	C <sub>t</sub>	V = 0 V, f = 1 MHz		15		pF
Transistor	Collector to Emitter Dark Current	I <sub>CEO</sub>	I <sub>F</sub> =0mA, V <sub>CE</sub> =40V			100	nA
Coupled	Current Transfer Ratio (I <sub>C</sub> /I <sub>F</sub> )*1	CTR	I <sub>F</sub> = 1 mA, V <sub>CE</sub> = 5 V	100	200	400	%
	Collector Saturation Voltage	V <sub>CE(sat)</sub>	I <sub>F</sub> = 1 mA, I <sub>C</sub> = 0.2 mA			0.3	V
	Isolation Resistance	R <sub>I-O</sub>	V <sub>I-O</sub> = 1kV <sub>DC</sub>	10 <sup>11</sup>			Ω
	Isolation Capacitance	C <sub>I-O</sub>	V = 0 V, f = 1 MHz		0.4		pF
	Rise Time*2	t <sub>r</sub>	V <sub>CC</sub> = 5 V, I <sub>C</sub> = 2 mA		4		μs
	Fall Time*2	t <sub>f</sub>	R <sub>L</sub> = 100 Ω		5		

\*1. CTR rank

CTR rank	CTR(%)	Condition
N	100 ~ 400	I <sub>F</sub> = 1 mA, V <sub>CE</sub> = 5 V
K	200 ~ 400	I <sub>F</sub> = 1 mA, V <sub>CE</sub> = 5 V
L	150 ~ 300	I <sub>F</sub> = 1 mA, V <sub>CE</sub> = 5 V
M	100 ~ 200	I <sub>F</sub> = 1 mA, V <sub>CE</sub> = 5 V

\*2. Test circuit for switching time

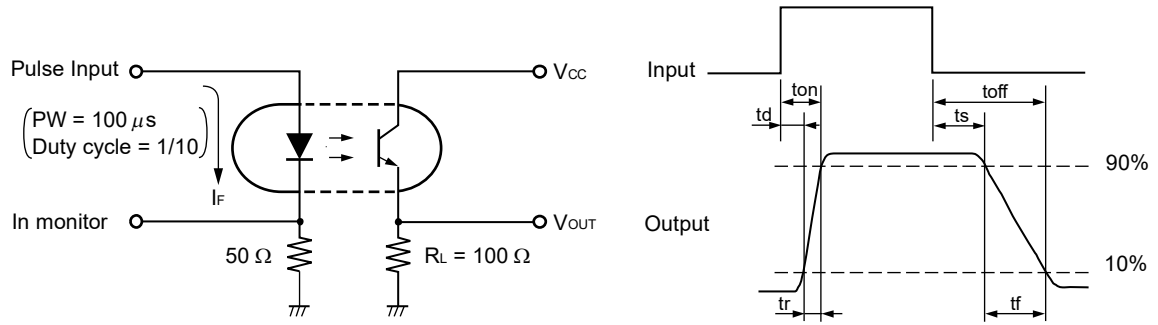

TYPICAL CHARACTERISTICS (TA = +25°C, unless otherwise specified)

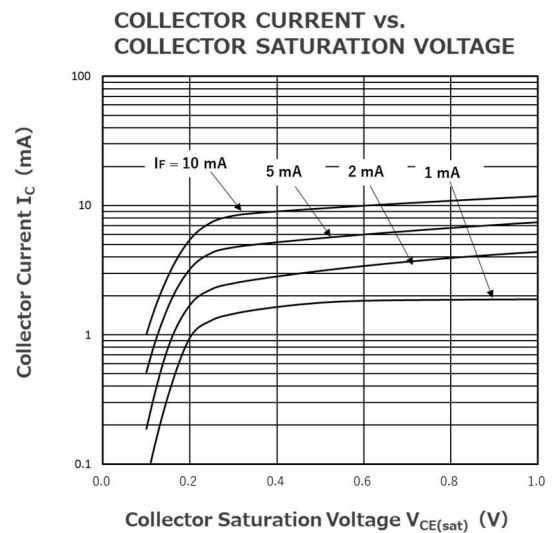
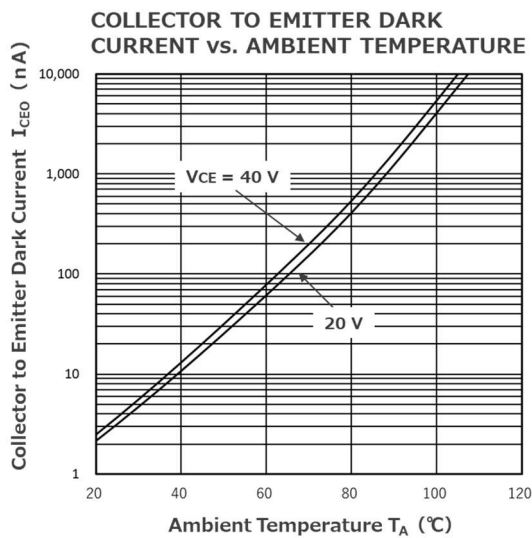
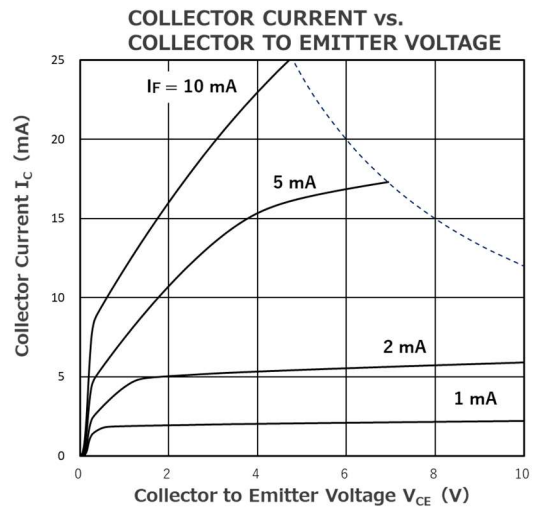
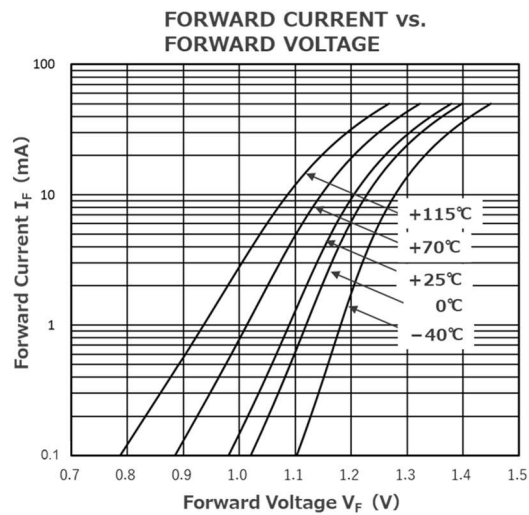
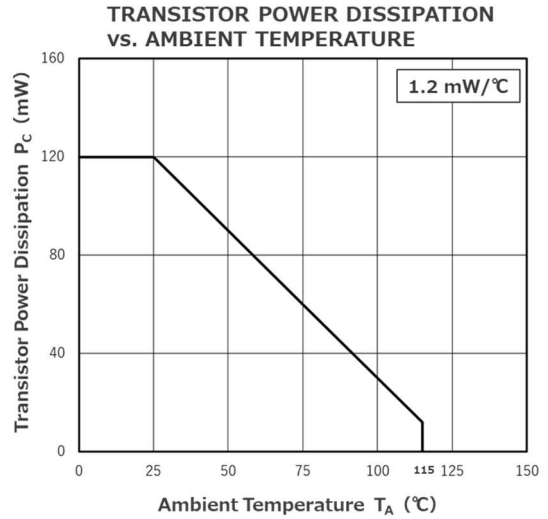
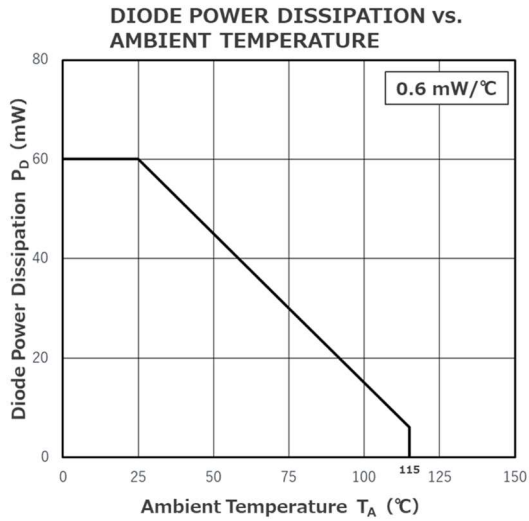

Remark The graphs indicate nominal characteristics.

TYPICAL CHARACTERISTICS (TA = +25°C, unless otherwise specified)

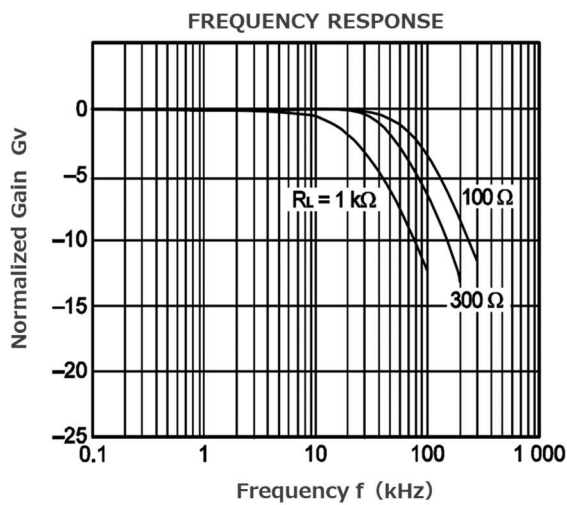
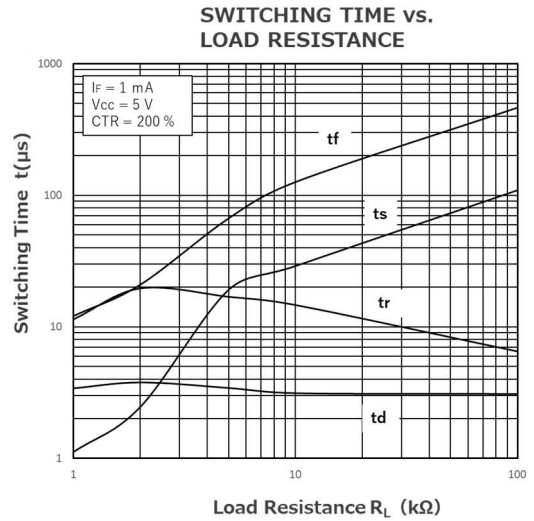
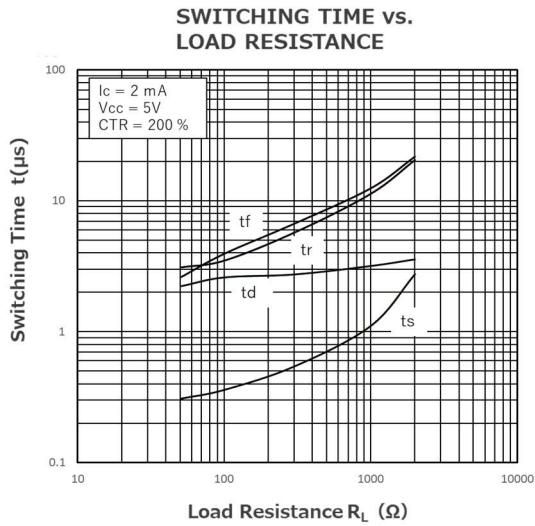
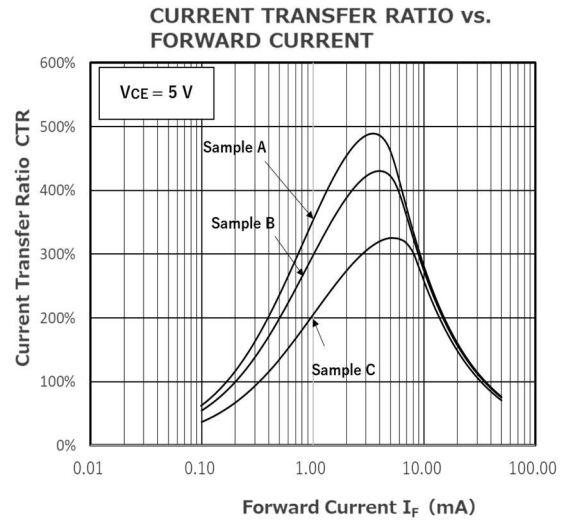
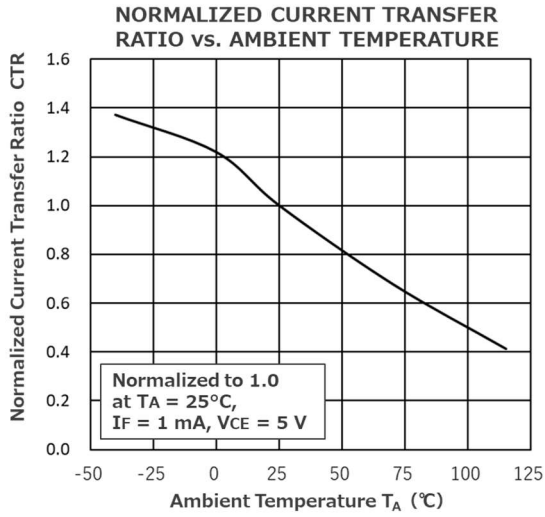

Remark The graphs indicate nominal characteristics.

TAPING SPECIFICATIONS (UNIT: mm)

Tape Direction

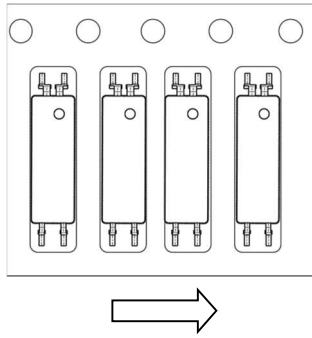

Outline and Dimensions (Tape)

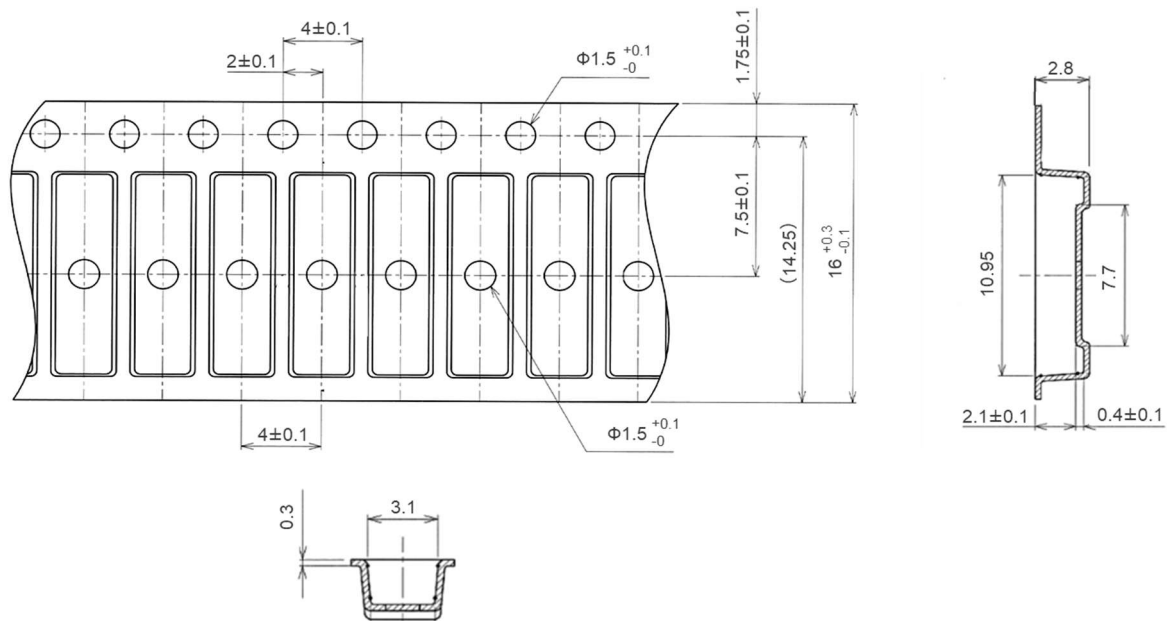

Outline and Dimensions (Reel)

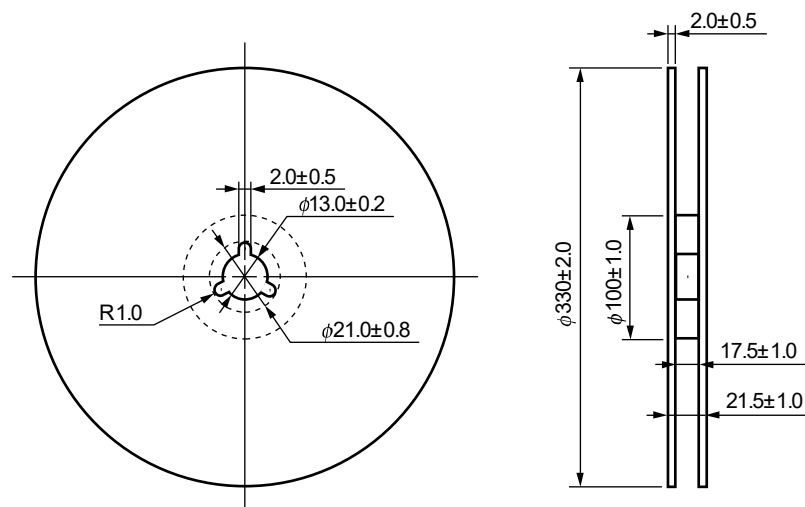

Packing: 3 500 pcs/reel



RECOMMENDED MOUNT PAD DIMENSIONS (UNIT : mm)

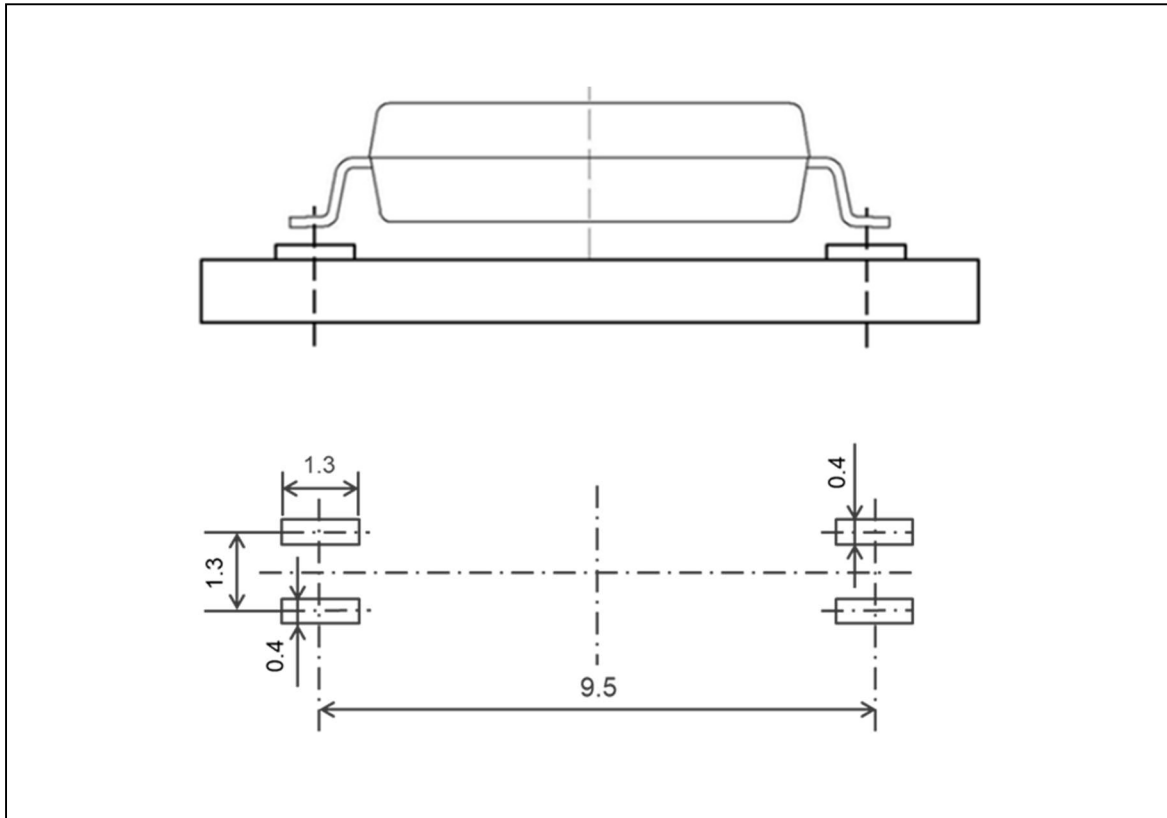

Remark All dimensions in this figure must be evaluated before use.

## NOTES ON HANDLING

## 1. Recommended soldering conditions

## (1) Infrared reflow soldering

- Peak reflow temperature 260°C or below (package surface temperature)
- Time of peak reflow temperature 10 seconds or less
- Time of temperature higher than 220°C 60 seconds or less
- Time to preheat temperature from 120 to 180°C 120±30 s
- Number of reflows Three
- Flux Rosin flux containing small amount of chlorine (The flux with a maximum chlorine content of 0.2 Wt% is recommended.)

Recommended Temperature Profile of Infrared Reflow

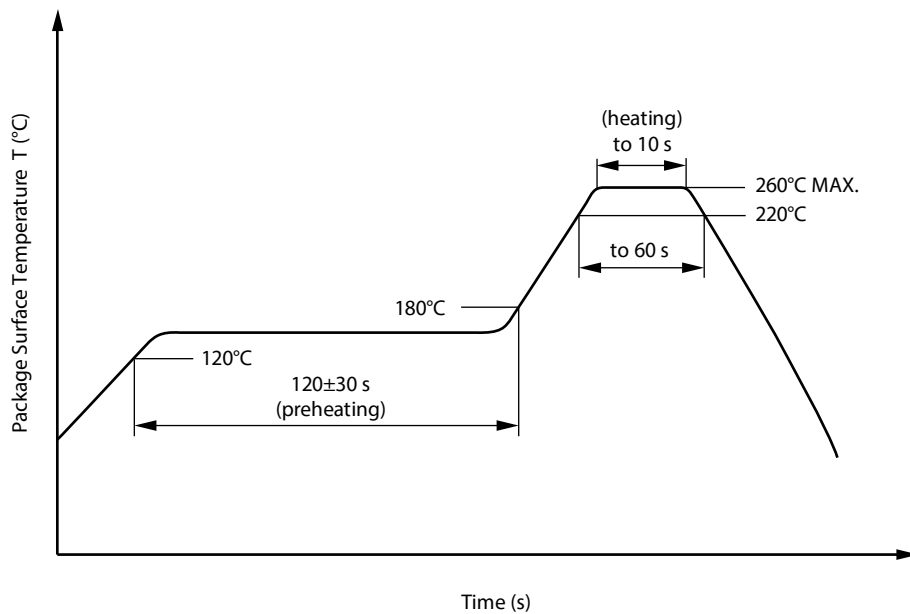

## (2) Wave soldering

- Temperature 260°C or below (molten solder temperature)
- Time 10 seconds or less
- Preheating conditions 120°C or below (package surface temperature)
- Number of times One (Allowed to be dipped in solder including plastic mold portion.)
- Flux Rosin flux containing small amount of chlorine (The flux with a maximum chlorine content of 0.2 Wt% is recommended.)

## (3) Soldering by Soldering Iron

- Peak Temperature (lead part temperature) 350°C or below
- Time (each pins) 3 seconds or less
- Flux Rosin flux containing small amount of chlorine (The flux with a maximum chlorine content of 0.2 Wt% is recommended.)

(a) Soldering of leads should be made at the point 1.5 to 2.0 mm from the root of the lead

(b) Please be sure that the temperature of the package would not be heated over 100°C

## (4) Cautions

- Flux Cleaning  
Avoid cleaning with Freon based or halogen-based (chlorinated etc.) solvents.
- Do not use fixing agents or coatings containing halogen-based substances.

## 2. Cautions regarding noise

Be aware that when voltage is applied suddenly between the photocoupler's input and output or between collector-emitters at startup, the output transistor may enter the on state, even if the voltage is within the absolute maximum ratings.

3. Measurement conditions of current transfer ratios (CTR), which differ according to photocoupler

Check the setting values before use, since the forward current conditions at CTR measurement differ according to product.

When using products other than at the specified forward current, the characteristics curves may differ from the standard curves due to CTR value variations or the like. Therefore, check the characteristics under the actual operating conditions and thoroughly take variations or the like into consideration before use.

## USAGE CAUTIONS

1. Protect against static electricity when handling.
2. Avoid storage at a high temperature and high humidity.

SPECIFICATION OF VDE MARKS LICENSE DOCUMENT

Parameter	Symbol	Rating	Unit
Climatic test class (IEC 60068-1/DIN EN 60068-1)		40/115/21	
Dielectric strength maximum operating isolation voltage	$U_{IORM}$	1 100	$V_{peak}$
Test voltage (partial discharge test, procedure a for type test and random test) $U_{pr} = 1.6 \times U_{IORM}, P_d < 5 \text{ pC}$	$U_{pr}$	1 760	$V_{peak}$
Test voltage (partial discharge test, procedure b for all devices) $U_{pr} = 1.875 \times U_{IORM}, P_d < 5 \text{ pC}$	$U_{pr}$	2 063	$V_{peak}$
Highest permissible overvoltage	$U_{IOTM}$	8 000	$V_{peak}$
Degree of pollution (IEC 60664-1/DIN EN 60664-1 (VDE 0110-1))		2	
Comparative tracking index (IEC 60112/DIN EN 60112 (VDE 0303-11))	CTI	400	
Material group (IEC 60664-1/DIN EN 60664-1 (VDE 0110-1))		II	
Storage temperature range	$T_{stg}$	-40~+125	°C
Operating temperature range	$T_A$	-40~+115	°C
Isolation resistance, minimum value $V_{IO} = 500 \text{ V dc at } T_A = 25^\circ\text{C}$ $V_{IO} = 500 \text{ V dc at } T_A \text{ MAX. at least } 100^\circ\text{C}$	Ris MIN. Ris MIN.	$10^{12}$ $10^{11}$	$\Omega$ $\Omega$
Safety maximum ratings (maximum permissible in case of fault, see thermal derating curve) Package temperature Current (input current $I_F$ , $\Psi_i = 0$ ) Power (output or total power dissipation) Isolation resistance $V_{IO} = 500 \text{ V dc at } T_A = T_{si}$	$T_{si}$ $I_{si}$ $\Psi_{si}$ Ris MIN.	175 400 700 $10^9$	°C mA mW $\Omega$

Method a) Destructive Test, Type and Sample Test

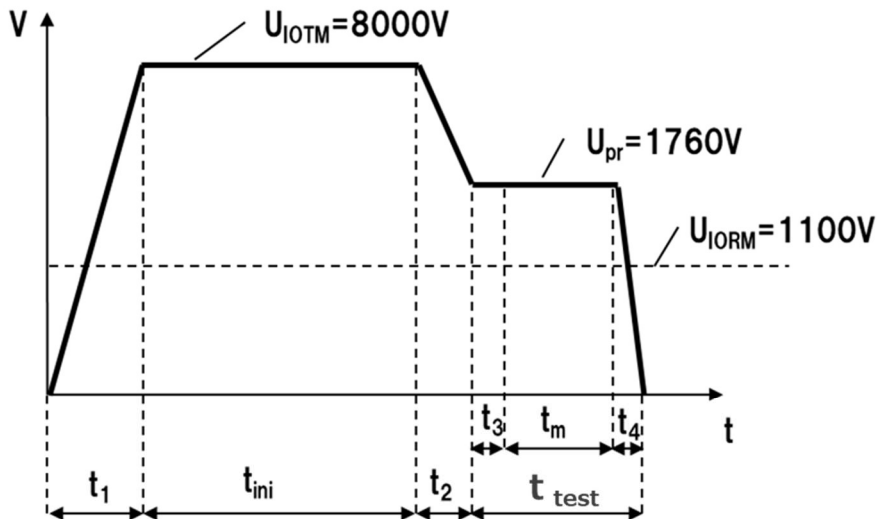

- $t_1, t_2 = 1 \text{ to } 10 \text{ sec}$
- $t_3, t_4 = 1 \text{ sec}$
- $t_m \text{ (PARTIAL DISCHARGE)} = 10 \text{ sec}$
- $t_{test} = 12 \text{ sec}$
- $t_{ini} = 60 \text{ sec}$

## Method b) Non-destructive Test, 100% Production Test

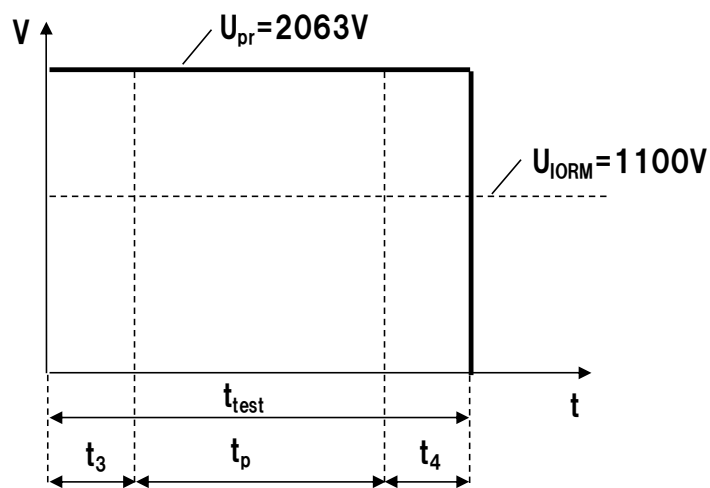

$$t_3, t_4 = 0.1 \text{ sec}$$

$$t_p \text{ (PARTIAL DISCHARGE)} = 1.0 \text{ sec}$$

$$t_{test} = 1.2 \text{ sec}$$

<b>Caution</b>	GaAs Products	<p>This product uses gallium arsenide (GaAs). GaAs vapor and powder are hazardous to human health if inhaled or ingested, so please observe the following points.</p> <ul style="list-style-type: none"><li>• Follow related laws and ordinances when disposing of the product. If there are no applicable laws and/or ordinances, dispose of the product as recommended below.<ol style="list-style-type: none"><li>1. Commission a disposal company able to (with a license to) collect, transport and dispose of materials that contain arsenic and other such industrial waste materials.</li><li>2. Exclude the product from general industrial waste and household garbage, and ensure that the product is controlled (as industrial waste subject to special control) up until final disposal.</li></ol></li><li>• Do not burn, destroy, cut, crush, or chemically dissolve the product.</li><li>• Do not lick the product or in any way allow it to enter the mouth.</li></ul>
----------------	---------------	--

All trademarks and registered trademarks are the property of their respective owners.