

# RV1S9062A

R08DS0270EJ0100

15 Mbps, HIGH CMTI, IPM DRIVER,  
5-PIN with 8 mm creepage distance package LSO5 PHOTOCOUPLER

Rev.1.00

May 09, 2022

## DESCRIPTION

The RV1S9062A is a photocoupler featuring high-speed switching up to 15 Mbps with active low output logic which consists of an AlGaAs LED on the input side and an integrated circuit with a photodiode on the output. The RV1S9062A is designed specifically for high common mode transient immunity (CMTI), wide operating power supply voltage range and high temperature operation up to  $T_A = 125\text{ }^\circ\text{C}$ . It is suitable for IPM (Intelligent Power Module) drive.

## FEATURES

- Long creepage distance (8 mm MIN.)
- High speed switching (15 Mbps)
- High common mode transient immunity ( $CM_H, CM_L = \pm 100\text{ kV}/\mu\text{s MIN.}$ )
- Pulse width distortion ( $|t_{PHL} - t_{PLH}| = 20\text{ ns MAX.}$ )
- Wide operating power supply voltage range ( $V_{CC} = 4.5 \sim 30\text{ V}$ )
- Operating ambient temperature ( $125\text{ }^\circ\text{C MAX.}$ )
- High isolation voltage ( $BV = 5\ 000\text{ Vr.m.s.}$ )
- Embossed tape product : RV1S9062ACCSP-10Yx#KC0 : 3 000 pcs/reel
- Pb-Free product
- Safety standard
  - UL : UL1577, Double protection
  - CSA : CAN/CSA-C22.2 No.62368-1, Reinforced insulation
  - VDE : DIN EN 60747-5-5 (Option)

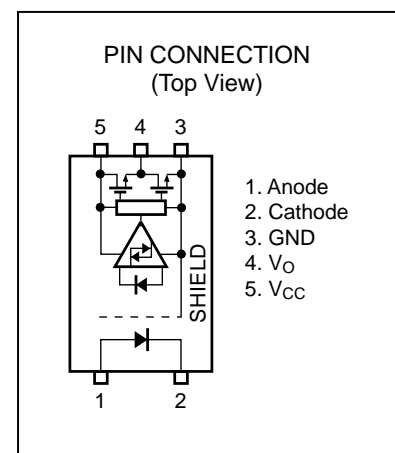

## APPLICATIONS

- IPM driver
- General purpose inverter

Start of mass production  
Apr. 2022

**PACKAGE DIMENSIONS (UNIT: mm)**

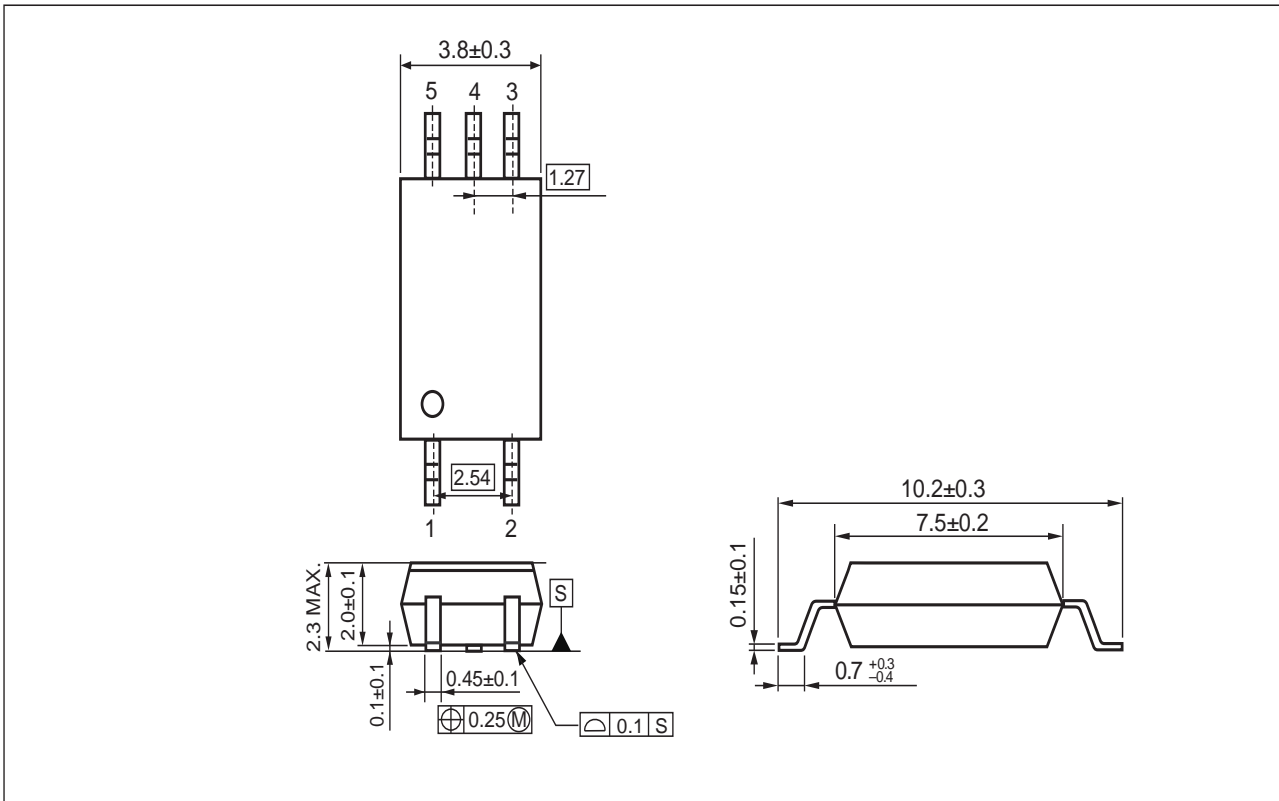

Weight : 0.119 g (Typ.)

**PHOTOCOUPLER CONSTRUCTION**

Parameter	MIN.
Air Distance	8 mm
Creepage Distance	8 mm
Isolation Distance	0.15 mm

**BLOCK DIAGRAM**

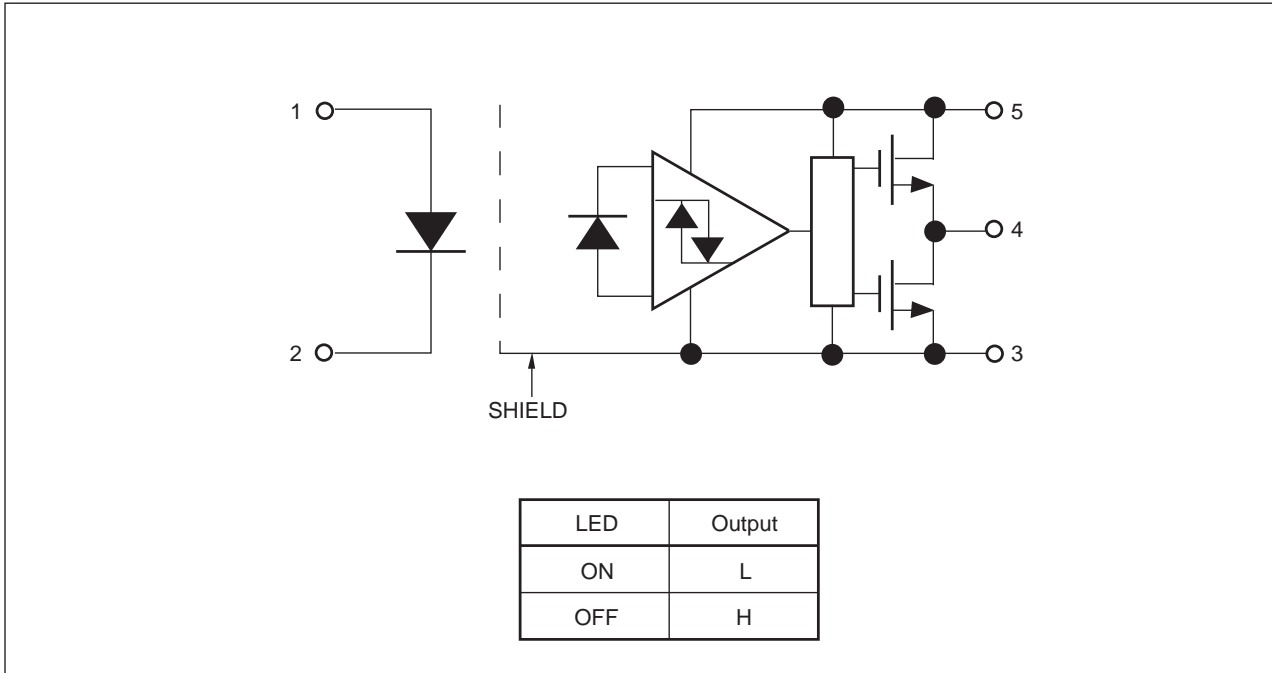

**MARKING EXAMPLE**

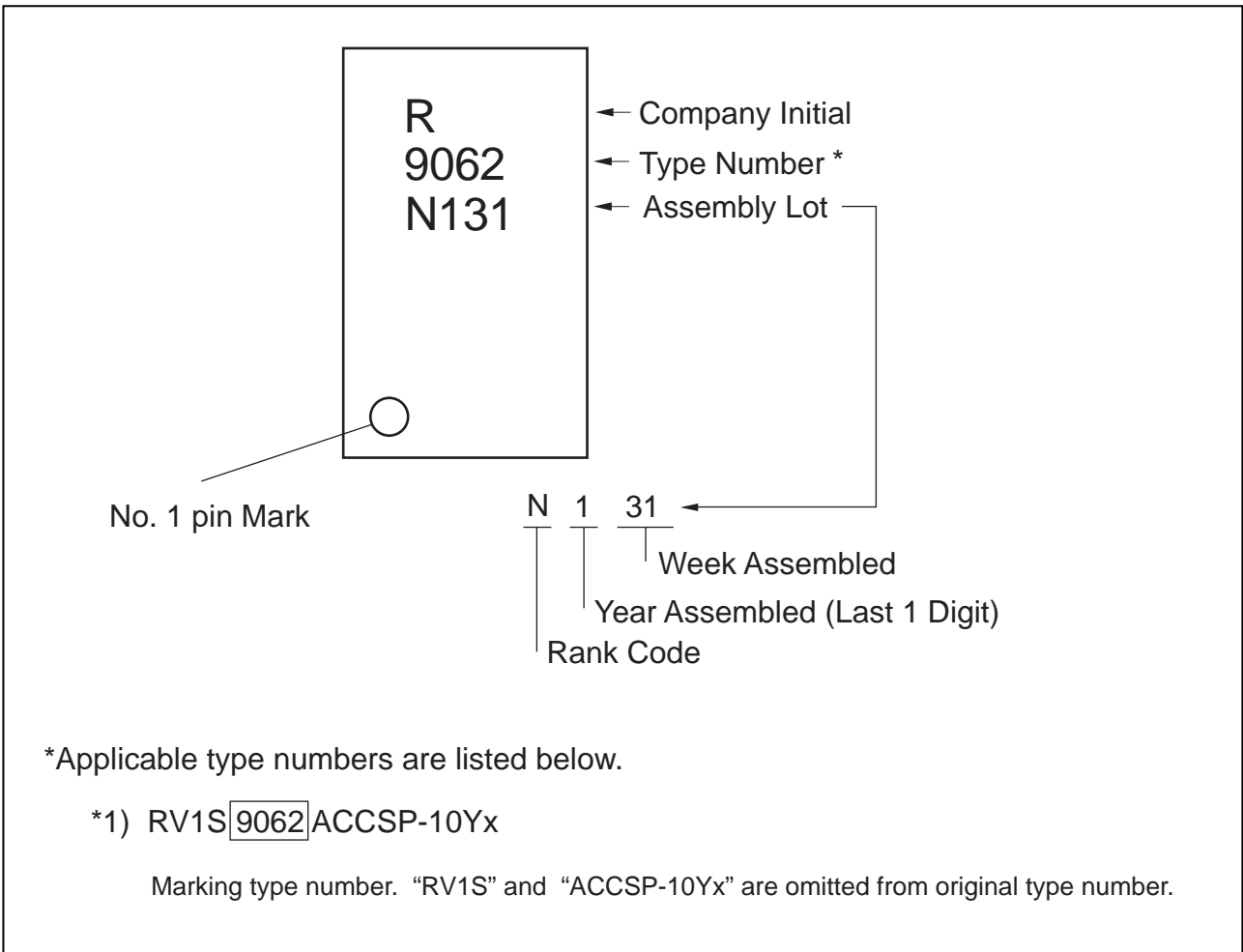

## ORDERING INFORMATION

Part Number	Order Number	Solder Plating Specification	Packing Style	Safety Standard Approval	Application Part Number <sup>*1</sup>
RV1S9062ACCSP -10YC	RV1S9062ACCSP -10YC#SC0	Pb-Free and Halogen Free (Ni/Pd/Au)	20 pcs (Tape 20 pcs cut)	Standard products (UL, CSA approved)	RV1S9062A
	RV1S9062ACCSP -10YC#KC0		Embossed Tape 3 000 pcs/reel		
RV1S9062ACCSP -10YV	RV1S9062ACCSP -10YV#SC0		20 pcs (Tape 20 pcs cut)	UL, CSA, DIN EN 60747-5-5 approved	
	RV1S9062ACCSP -10YV#KC0		Embossed Tape 3 000 pcs/reel		

Notes:\*1. For the application of the Safety Standard, following part number should be used.

ABSOLUTE MAXIMUM RATINGS (T<sub>A</sub> = 25 °C, unless otherwise specified)

Parameter		Symbol	Ratings	Unit
Diode	Forward Current <sup>*1</sup>	I <sub>F</sub>	25	mA
	Reverse Voltage	V <sub>R</sub>	5	V
Detector	Supply Voltage	V <sub>CC</sub>	-0.5 to +30	V
	Output Voltage	V <sub>O</sub>	-0.5 to V <sub>CC</sub>	V
	Output Current	I <sub>O</sub>	25	mA
	Power Dissipation <sup>*2</sup>	P <sub>C</sub>	250	mW
Isolation Voltage <sup>*3</sup>		BV	5 000	Vr.m.s.
Operating Ambient Temperature		T <sub>A</sub>	-40 to +125	°C
Storage Temperature		T <sub>stg</sub>	-55 to +150	°C

Notes: \*1. Reduced to 0.325 mA/°C at T<sub>A</sub> = 85 °C or more.

\*2. Reduced to 4.15 mW/°C at T<sub>A</sub> = 85 °C or more.

\*3. AC voltage for 1 minute at T<sub>A</sub> = 25 °C, RH = 60 % between input and output.

Pins 1-2 shorted together, 3-5 shorted together.

## RECOMMENDED OPERATING CONDITIONS

Parameter	Symbol	MIN.	TYP.	MAX.	Unit
Supply Voltage	V <sub>CC</sub>	4.5		30	V
Forward Current (ON)	I <sub>F(ON)</sub>	6		12	mA
Forward Voltage (OFF)	V <sub>F(OFF)</sub>	0		0.8	V
Supply Voltage Ramp Slew Rate	SR			0.5	V/μs
Operating Ambient Temperature	T <sub>A</sub>	-40		125	°C

**ELECTRICAL CHARACTERISTICS ( $T_A = -40$  to  $+125$  °C,  $V_{CC} = 4.5$  to  $30$  V)**

Parameter		Symbol	Conditions	MIN.	TYP.*1	MAX.	Unit
Diode	Forward Voltage	$V_F$	$I_F = 6$ mA, $T_A = 25$ °C	1.4	1.54	1.7	V
	Reverse Current	$I_R$	$V_R = 3$ V, $T_A = 25$ °C			10	$\mu$ A
	Input Capacitance	$C_t$	$V_F = 0$ V, $f = 1$ MHz		30		pF
Detector	Low Level Output Voltage	$V_{OL}$	$I_F = 6$ mA, $I_O = 3.5$ mA			0.3	V
			$I_F = 6$ mA, $I_O = 6.5$ mA			0.5	
	High Level Output Voltage	$V_{OH}$	$I_F = 0$ mA, $I_O = -3.5$ mA	$V_{CC}-1.5$			V
			$I_F = 0$ mA, $I_O = -6.5$ mA	$V_{CC}-2.0$			
	Low Level Supply Current	$I_{CCL}$	$I_F = 6$ mA, $V_{CC} = 30$ V		1.7	3	mA
	High Level Supply Current	$I_{CCH}$	$I_F = 0$ mA, $V_{CC} = 30$ V		1.7	3	mA
	UVLO Threshold	$V_{UVLO}$	$V_O < 1$ V, $I_F = 0$ mA		3		V
Coupled	Threshold Input Current (H $\rightarrow$ L)	$I_{FHL}$	$V_{CC} = 15$ V, $V_O < 0.3$ V, $I_O = 3.5$ mA			4.1	mA
	Isolation Resistance	$R_{I-O}$	$V_{I-O} = 1$ kV dc, $R_H \leq 60$ %, $T_A = 25$ °C	$10^{11}$			$\Omega$
	Isolation Capacitance	$C_{I-O}$	$V = 0$ V, $f = 1$ MHz		0.6		pF
	Propagation Delay Time (H $\rightarrow$ L) *2	$t_{PHL}$	$V_{IN} = 0 \rightarrow 5$ V, $C_{IN} = 60$ pF, $R_{IN} = 560$ $\Omega$ , $C_L = 15$ pF, $V_{THHL} = 1.3$ V			60	ns
	Propagation Delay Time (L $\rightarrow$ H) *2	$t_{PLH}$	$V_{IN} = 5 \rightarrow 0$ V, $C_{IN} = 60$ pF, $R_{IN} = 560$ $\Omega$ , $C_L = 15$ pF, $V_{THLH} = 1.3$ V			60	ns
	Pulse Width Distortion (PWD)	$ t_{PHL}-t_{PLH} $	$V_{IN} = 0 \leftrightarrow 5$ V, $C_{IN} = 60$ pF, $R_{IN} = 560$ $\Omega$ , $C_L = 15$ pF, $V_{THHL}=V_{THLH}= 1.3$ V			20	ns
	Propagation Delay Difference Between Any Two Parts (PDD)					25	
	Common Mode Transient Immunity at High Level Output *3	$ CM_H $	$V_{CC} = 30$ V, $T_A = 25$ °C, $V_O > 17$ V, $I_F = 0$ mA, $ V_{CM}  = 1.5$ kV	100			kV/ $\mu$ s
	Common Mode Transient Immunity at Low Level Output *3	$ CM_L $	$V_{CC} = 30$ V, $T_A = 25$ °C, $V_O < 1$ V, $I_F = 6$ mA, $ V_{CM}  = 1.5$ kV	100			kV/ $\mu$ s

Notes: \*1. Typical values at  $T_A = 25$  °C.

\*2. Test circuit for propagation delay time

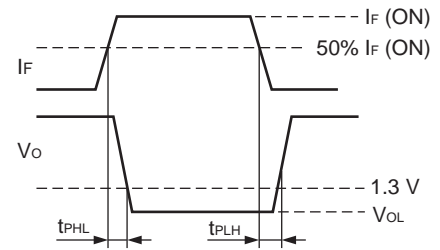
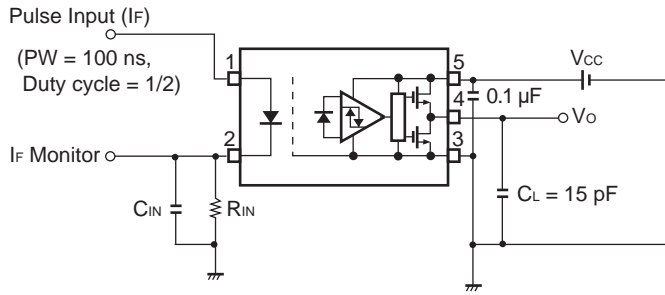

Remark  $C_L$  includes probe and stray wiring capacitance.

\*3. Test circuit for common mode transient immunity

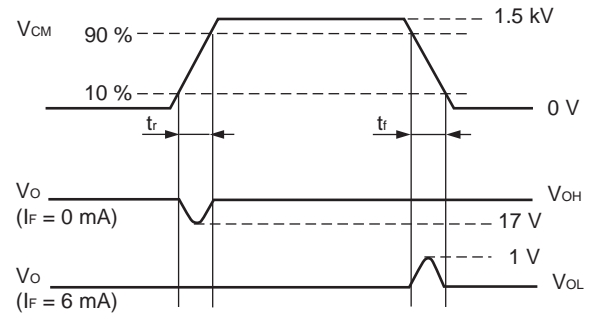
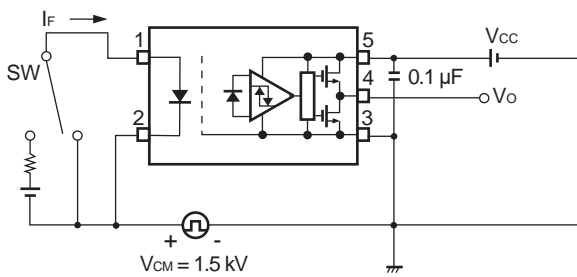

**TYPICAL CHARACTERISTICS ( $T_A = 25\text{ }^\circ\text{C}$ , unless otherwise specified)**

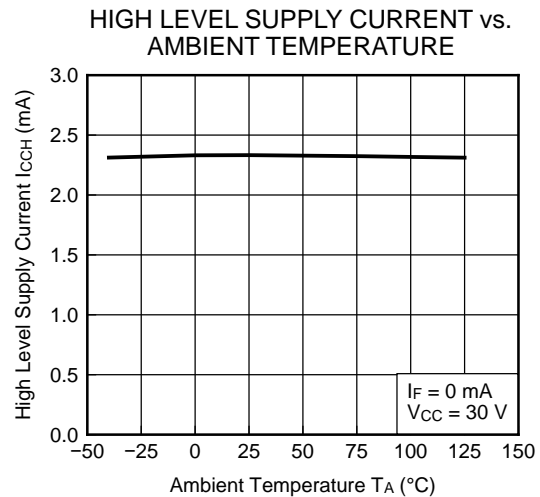
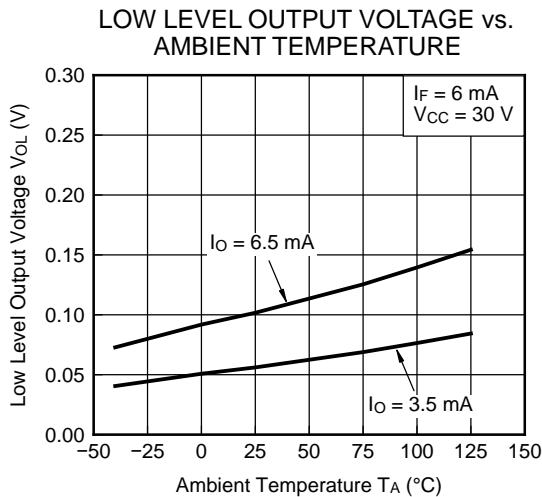
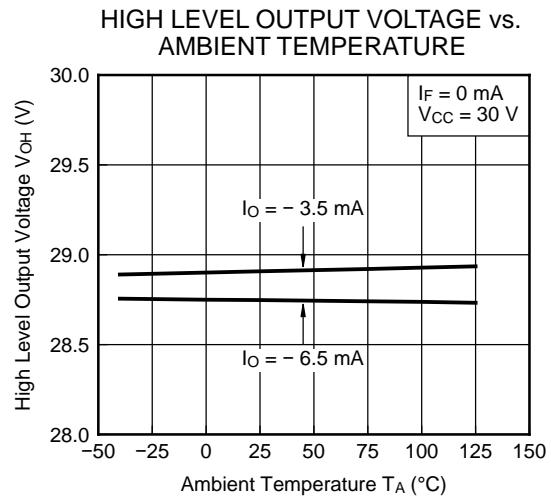
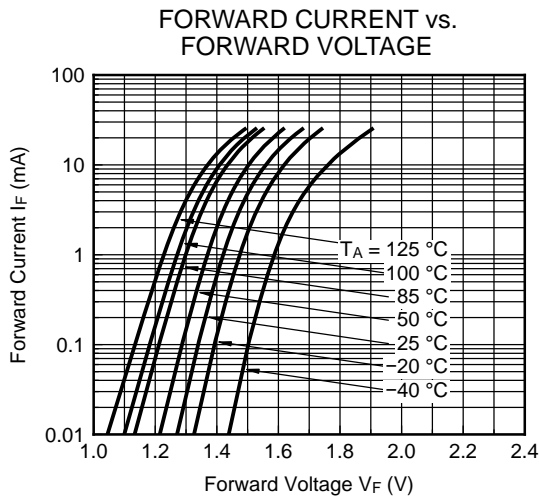
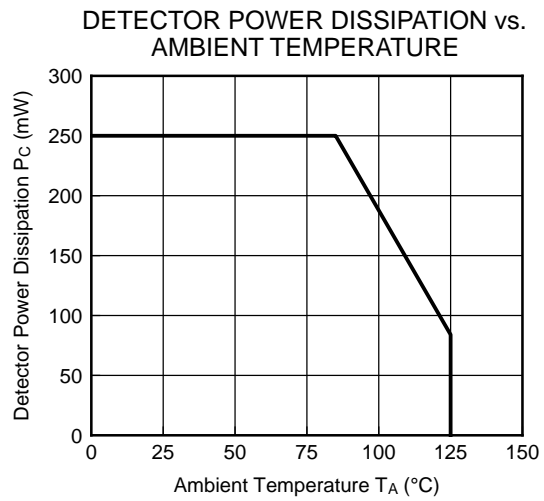
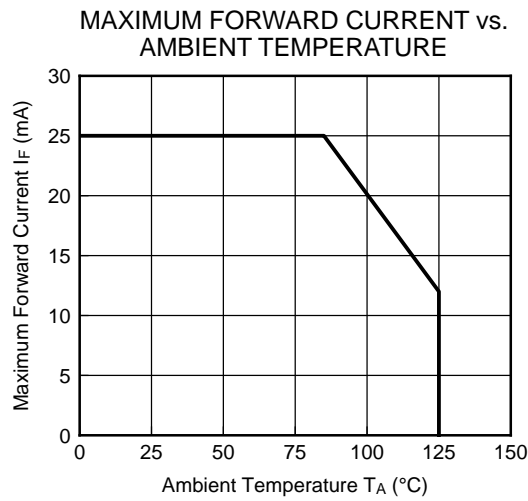

Remark The graphs indicate nominal characteristics.

TYPICAL CHARACTERISTICS (T<sub>A</sub> = 25 °C, unless otherwise specified)

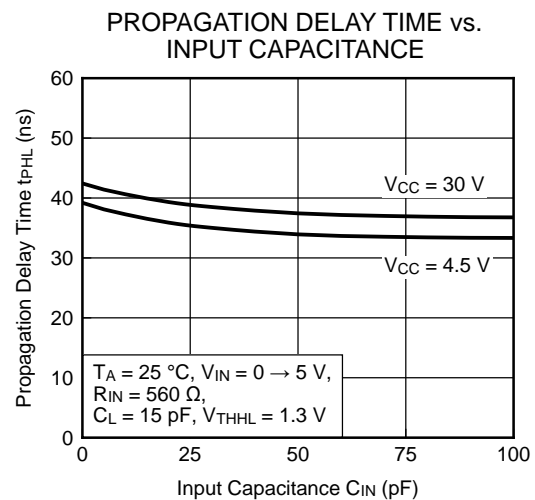
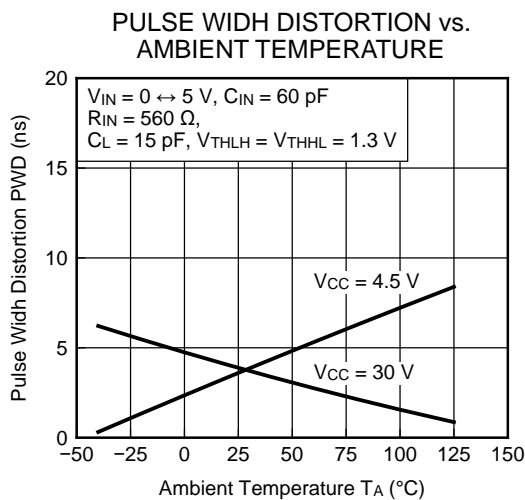
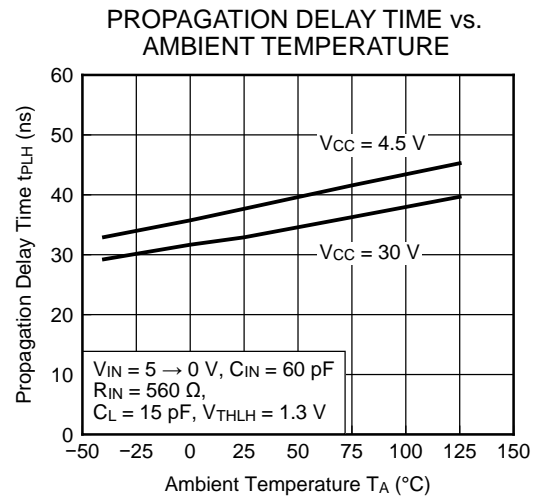
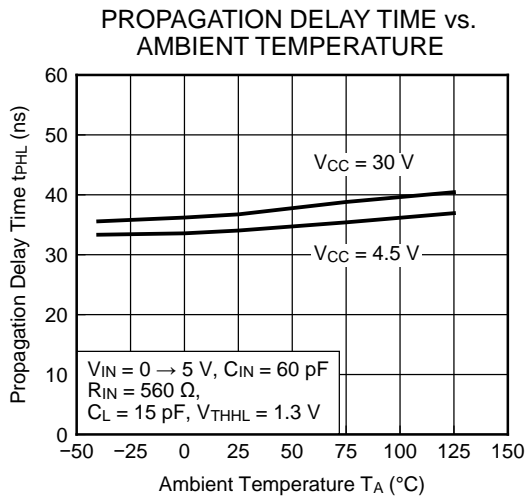
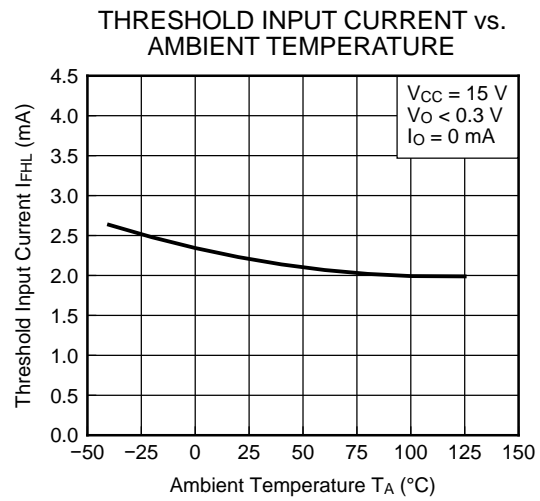
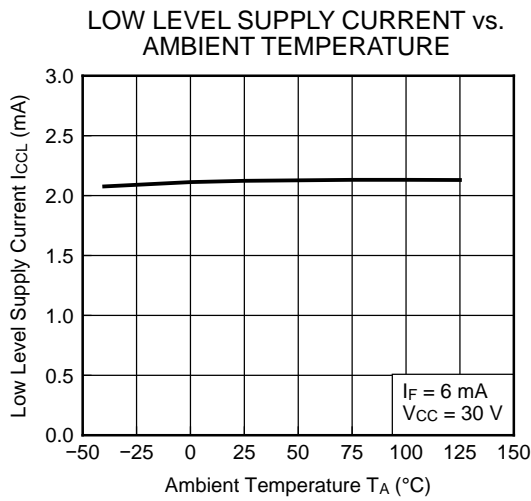

Remark The graphs indicate nominal characteristics.



**TYPICAL CHARACTERISTICS (T<sub>A</sub> = 25 °C, unless otherwise specified)**

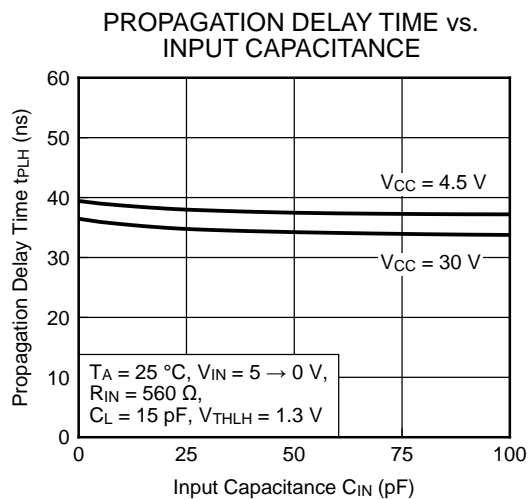

Remark The graphs indicate nominal characteristics.

**TAPING SPECIFICATIONS (UNIT : mm)**

Tape Direction

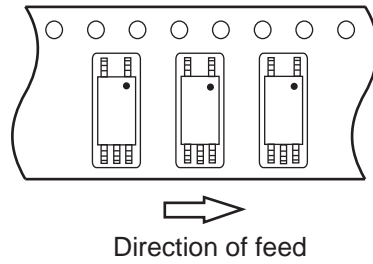

Outline and Dimensions (Tape)

(Unit : mm)

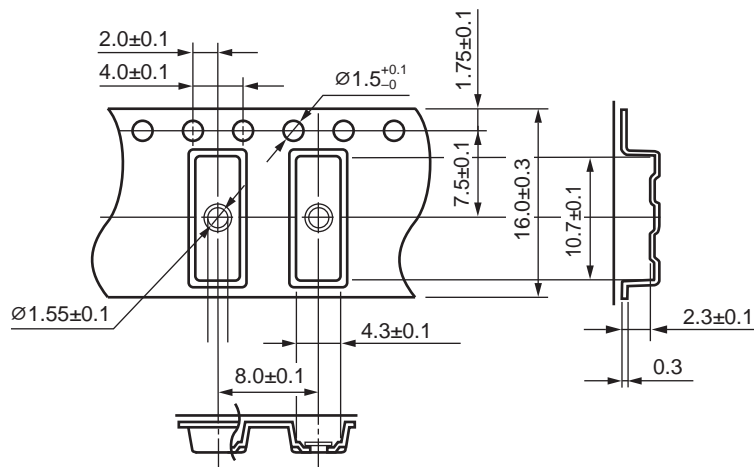

Outline and Dimensions (Reel)

(Unit : mm)

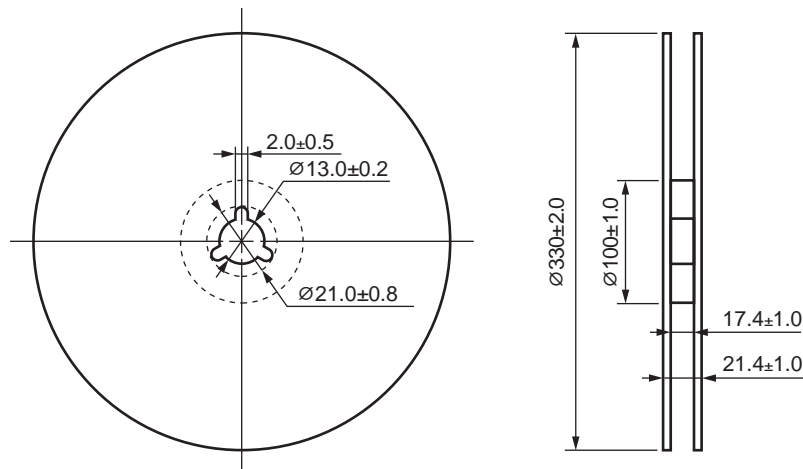

Packing: 3 000 pcs/reel

RECOMMENDED MOUNT PAD DIMENSIONS (UNIT : mm)

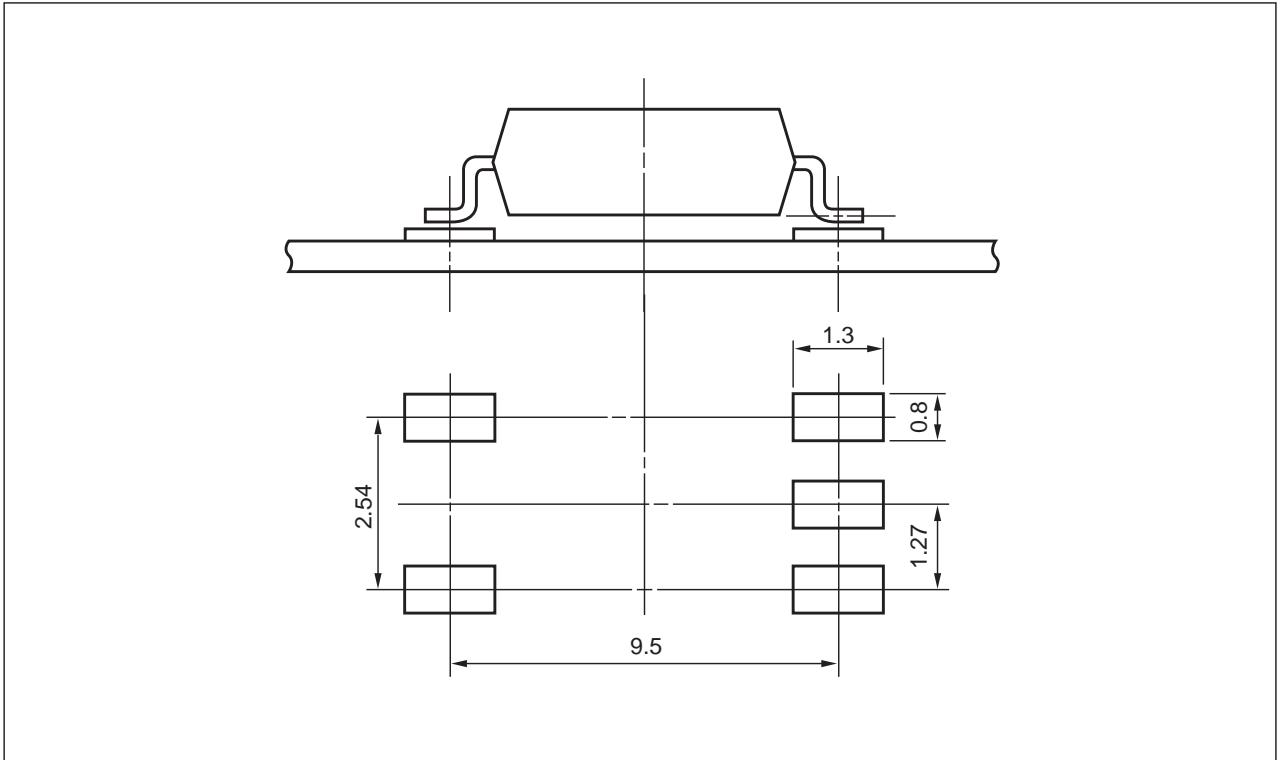

Remark All dimensions in this figure must be evaluated before use.

## NOTES ON HANDLING

### 1. Recommended soldering conditions

#### (1) Infrared reflow soldering

- Peak reflow temperature 260 °C or below (package surface temperature)
- Time of peak reflow temperature -5 °C (255 °C) 30 seconds or less
- Time of temperature higher than 217 °C 60~150 seconds
- Time to preheat temperature from 150 to 200 °C 60~120 seconds
- Number of reflows Three
- Flux Rosin flux containing small amount of chlorine (The flux with a maximum chlorine content of 0.2 Wt% is recommended.)

Recommended Temperature Profile of Infrared Reflow

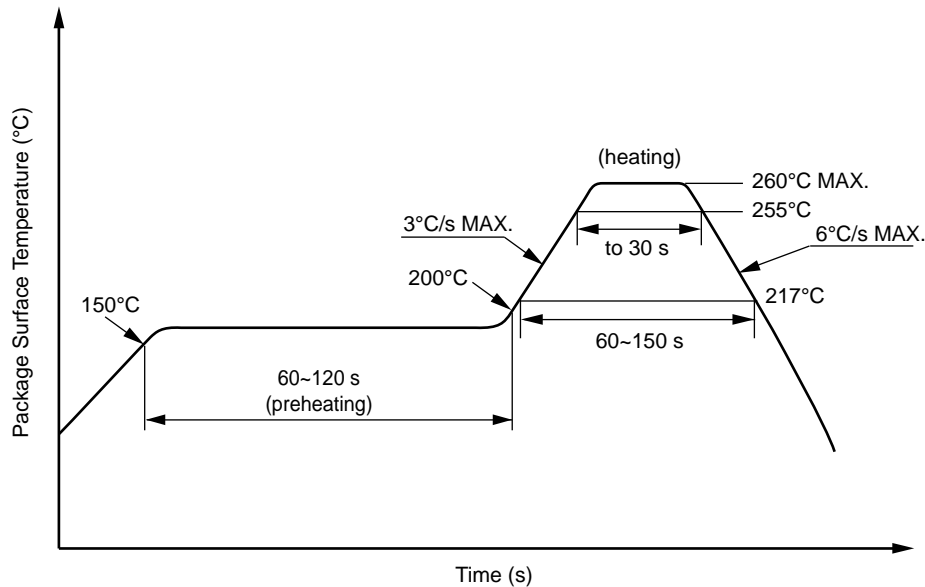

JEDEC J-STD-020D compliant soldering conditions

#### (2) Wave soldering

- Temperature 260 °C or below (molten solder temperature)
- Time 10 seconds or less
- Preheating conditions 120 °C or below (package surface temperature)
- Number of times One (Allowed to be dipped in solder including plastic mold portion.)
- Flux Rosin flux containing small amount of chlorine (The flux with a maximum chlorine content of 0.2 Wt% is recommended.)

#### (3) Soldering by Soldering Iron

- Peak Temperature (lead part temperature) 350 °C or below
  - Time (each pins) 3 seconds or less
  - Flux Rosin flux containing small amount of chlorine (The flux with a maximum chlorine content of 0.2 Wt% is recommended.)
- Soldering of leads should be made at the point 1.5 to 2.0 mm from the root of the lead

#### (4) Cautions

- Flux Cleaning  
Avoid cleaning with Freon based or halogen-based (chlorinated etc.) solvents.
- Do not use fixing agents or coatings containing halogen-based substances.

2. Cautions regarding noise

Be aware that when voltage is applied suddenly between the photocoupler's input and output at startup, the output transistor may enter the on state, even if the voltage is within the absolute maximum ratings.

**USAGE CAUTIONS**

1. This product is weak for static electricity by designed with high-speed integrated circuit so protect against static electricity when handling.
2. By-pass capacitor of more than 0.1  $\mu\text{F}$  is used between  $V_{\text{CC}}$  and GND near device. Also, ensure that the distance between the leads of the photocoupler and capacitor is no more than 10 mm.
3. Avoid storage at a high temperature and high humidity.

## SPECIFICATION OF VDE MARKS LICENSE DOCUMENT

Parameter	Symbol	Rating	Unit
Climatic test class (IEC 60068-1/DIN EN 60068-1)		40/125/21	
Dielectric strength maximum operating isolation voltage	$V_{IORM}$	1 130	$V_{peak}$
Test voltage (partial discharge test, procedure a for type test and random test) $V_m = 1.6 \times V_{IORM}, q_{pd} < 5 \text{ pC}$	$V_m$	1 808	$V_{peak}$
Test voltage (partial discharge test, procedure b for all devices) $V_m = 1.875 \times V_{IORM}, q_{pd} < 5 \text{ pC}$	$V_m$	2 119	$V_{peak}$
Highest permissible overvoltage	$V_{IOTM}$	8 000	$V_{peak}$
Degree of pollution (IEC 60664-1/DIN EN 60664-1 (VDE 0110-1))		2	
Comparative tracking index (IEC 60112/DIN EN 60112 (VDE 0303-11))	CTI	400	
Material group (IEC 60664-1/DIN EN 60664-1 (VDE 0110-1))		II	
Storage temperature range	$T_{stg}$	-55~+150	°C
Operating temperature range	$T_A$	-40~+125	°C
Isolation resistance, minimum value $V_{I-O} = 500 \text{ V dc}, T_A = 25 \text{ °C}$	$R_{I-O \text{ MIN.}}$	$10^{12}$	$\Omega$
$V_{I-O} = 500 \text{ V dc}, T_A = \text{maximum temperature of rating, at least } 100 \text{ °C}$	$R_{I-O \text{ MIN.}}$	$10^{11}$	$\Omega$
Safety maximum ratings (maximum permissible in case of fault, see thermal derating curve)			
Maximum ambient temperature	$T_S$	175	°C
Maximum input current	$I_{SI}$	400	mA
Maximum output power dissipation	$P_{SO}$	700	mW
Isolation resistance, minimum value at $V_{I-O} = 500 \text{ V dc}, T_A = T_S$	$R_{I-O \text{ MIN.}}$	$10^9$	$\Omega$

## Dependence of maximum safety ratings on ambient temperature

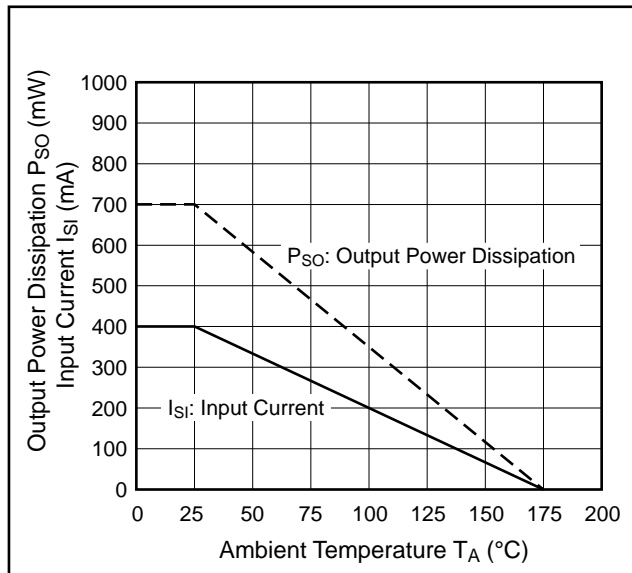

**Method a) Destructive Test, Type and Sample Test**

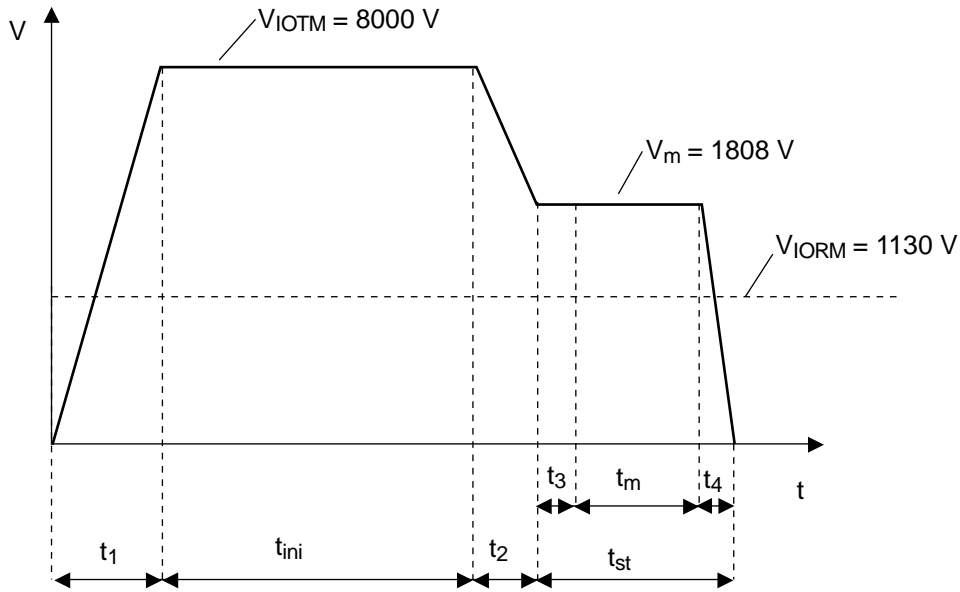

$t_1, t_2 = 1 \text{ to } 10 \text{ sec}$   
 $t_3, t_4 = 1 \text{ sec}$   
 $t_m = 10 \text{ sec}$   
 $t_{st} = 12 \text{ sec}$   
 $t_{ini} = 60 \text{ sec}$

**Method b) Non-destructive Test, 100% Production Test**

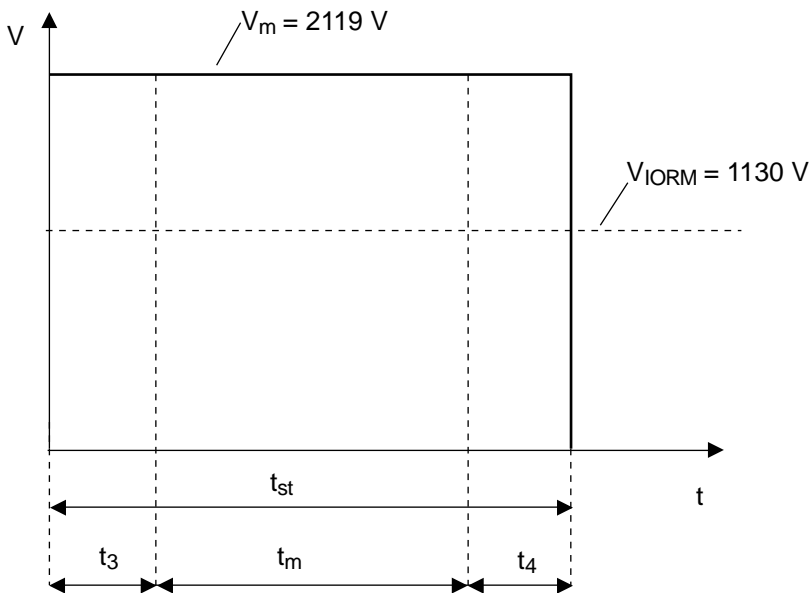

$t_3, t_4 = 0.1 \text{ sec}$   
 $t_m = 1.0 \text{ sec}$   
 $t_{st} = 1.2 \text{ sec}$

<b>Caution</b>	GaAs Products	<p>This product uses gallium arsenide (GaAs). GaAs vapor and powder are hazardous to human health if inhaled or ingested, so please observe the following points.</p> <ul style="list-style-type: none"><li>• Follow related laws and ordinances when disposing of the product. If there are no applicable laws and/or ordinances, dispose of the product as recommended below.<ol style="list-style-type: none"><li>1. Commission a disposal company able to (with a license to) collect, transport and dispose of materials that contain arsenic and other such industrial waste materials.</li><li>2. Exclude the product from general industrial waste and household garbage, and ensure that the product is controlled (as industrial waste subject to special control) up until final disposal.</li></ol></li><li>• Do not burn, destroy, cut, crush, or chemically dissolve the product.</li><li>• Do not lick the product or in any way allow it to enter the mouth.</li></ul>
----------------	---------------	--

All trademarks and registered trademarks are the property of their respective owners.