

# RV1S9184Q

R08DS0190EJ0200

Rev.2.00

Mar 09, 2023

AUTOMOTIVE 1 Mbps, OPEN COLLECTOR OUTPUT, 5-PIN SOP (SO5) PHOTOCOUPLER

## DESCRIPTION

The RV1S9184Q is a photocopler featuring high-speed communication with open-collector output which consists of an AlGaAs LED on the input side and a one-chip signal processing circuit with built-in photo diode on the output side. The package is a small outline package (SOP) type and has a shield effect to cut the ambient light. The RV1S9184Q is designed specifically for high voltage isolation and wide temperature operation (-40 to +135 °C), which is suitable for automotive application.

## FEATURES

- Operating ambient temperature ( $T_A = -40$  to  $+135$  °C)
- High isolation voltage ( $BV = 3\ 750$  Vr.m.s.)
- High speed response ( $t_{PHL} = 700$  ns MAX.,  $t_{PLH} = 700$  ns MAX.,  $PWD = 500$  ns MAX.)
- High common mode transient immunity ( $CM_H, CM_L = \pm 15$  kV/ $\mu$ s MIN.)
- Small package (SO5)
- Pb-free product
- AEC-Q100 (Grade 1:  $T_A = -40$  to  $+125$  °C) compliant
- Safety standard
- •UL : UL1577, Double protection

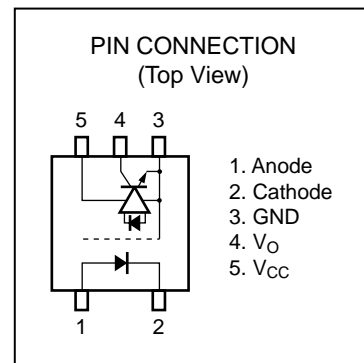

## APPLICATIONS

- Consumer Vehicle

Start of mass production  
Feb.2020

PACKAGE DIMENSIONS (UNIT: mm)

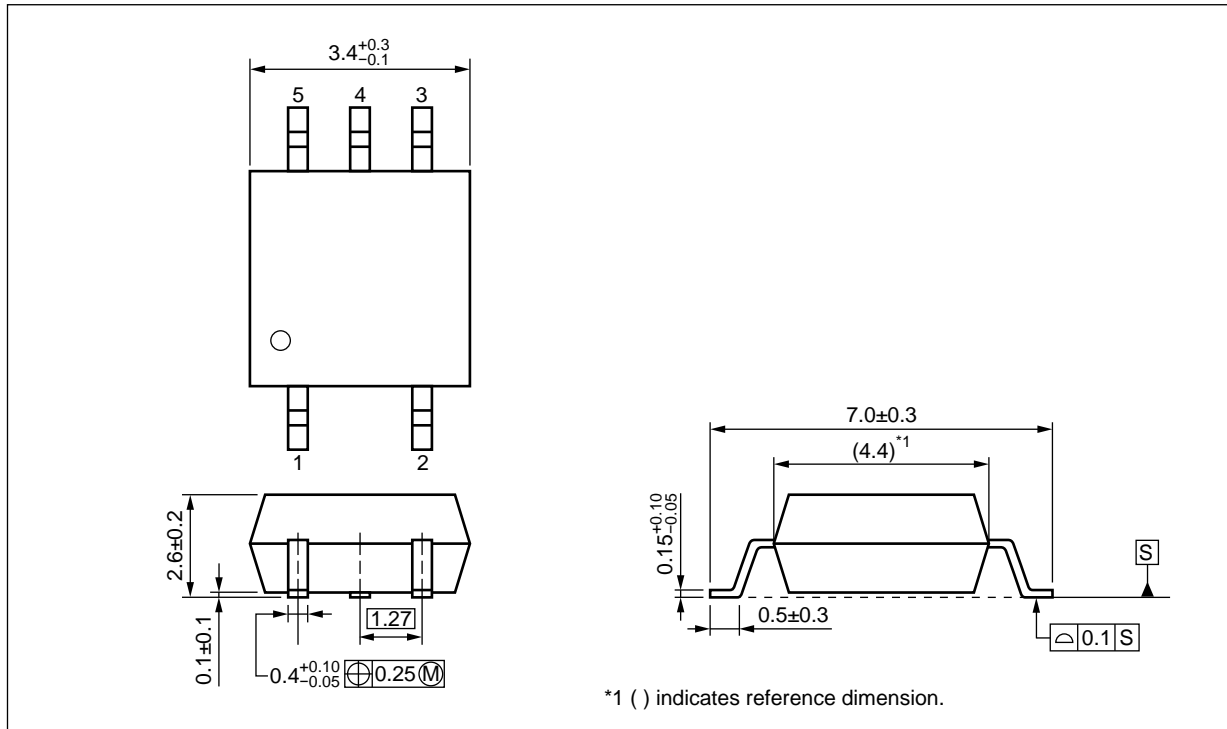

Weight : 0.08 g (TYP.)

PHOTOCOUPLER CONSTRUCTION

Parameter	MIN.
Air Distance	4.2 mm
Creepage Distance	4.2 mm
Isolation Distance	0.2 mm

MARKING EXAMPLE

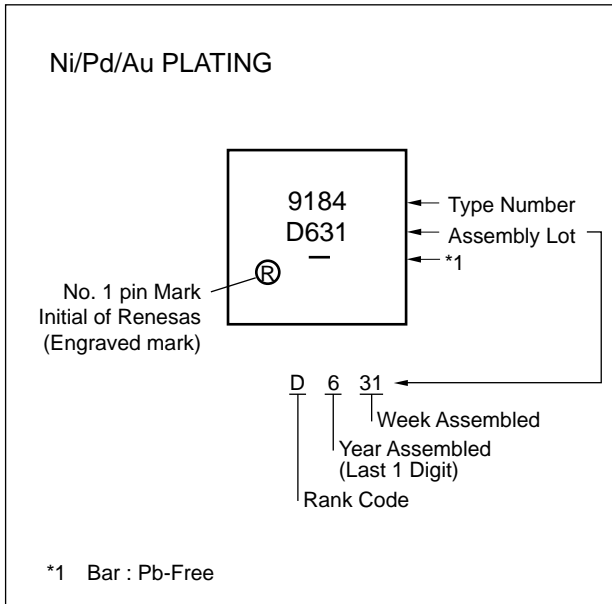

ORDERING INFORMATION

Part Number	Order Number	Solder Plating Specification	Packing Style	Safety Standard Approval	Application Part Number *1
RV1S9184QKCSP-1000	RV1S9184QKCSP-1000#SC0/D	Pb-Free (Ni/Pd/Au)	Embossed Tape 20 pcs	Standard Products (UL Approved)	RV1S9184Q
	RV1S9184QKCSP-1000#KC0/D		Embossed Tape 2 500 pcs/reel		

Notes: \*1. For the application of the safety standard, the following part number should be used.

ABSOLUTE MAXIMUM RATINGS (T<sub>A</sub> = 25 °C, unless otherwise specified)

Parameter		Symbol	Ratings	Unit
Diode	Forward Current *1	I <sub>F</sub>	25	mA
	Reverse Voltage	V <sub>R</sub>	5	V
Detector	Supply Voltage	V <sub>CC</sub>	-0.5 to +30	V
	Output Voltage	V <sub>O</sub>	-0.5 to V <sub>CC</sub>	V
	Output Current	I <sub>O</sub>	15	mA
	Power Dissipation *2	P <sub>C</sub>	100	mW
Isolation Voltage *3		BV	3 750	Vr.m.s.
Operating Ambient Temperature		T <sub>A</sub>	-40 to +135	°C
Storage Temperature		T <sub>stg</sub>	-55 to +150	°C

Notes: \*1. Reduced at a rate of 0.5 mA/°C above T<sub>A</sub> = 115 °C.

\*2. Reduced at a rate of 1.5 mW/°C above T<sub>A</sub> = 75 °C.

\*3 AC voltage for 1 minute at T<sub>A</sub> = 25 °C, RH = 60 % between input and output.

Pins 1-2 shorted together, 3-4 shorted together.

RECOMMENDED OPERATING CONDITIONS

Parameter	Symbol	MIN.	TYP.	MAX.	Unit
Supply Voltage	V <sub>CC</sub>	4.5	15	20	V
Output Voltage	V <sub>O</sub>	0		20	V
Forward Current (ON) *1	I <sub>F(ON)</sub>	6		20	mA
Forward Voltage (OFF)	V <sub>F(OFF)</sub>	0		0.8	V

Notes: \*1. Forward current at T<sub>A</sub> = 115 °C or more should not exceed absolute maximum ratings.

ELECTRICAL CHARACTERISTICS (T<sub>A</sub> = - 40 to + 135 °C, unless otherwise specified)

Parameter		Symbol	Conditions	MIN.	TYP. *1	MAX.	Unit
Diode	Forward Voltage	V <sub>F</sub>	I <sub>F</sub> = 10 mA	1.18	1.65	1.98	V
	Reverse Current	I <sub>R</sub>	V <sub>R</sub> = 3 V		0.1	100	μA
Detector	High Level Output Current	I <sub>OH</sub>	I <sub>F</sub> = 0 mA, V <sub>CC</sub> = V <sub>O</sub> = 20 V		0.01	50	μA
	Low Level Output Voltage	V <sub>OL</sub>	I <sub>F</sub> = 5 mA, I <sub>O</sub> = 2 mA, V <sub>CC</sub> = 15 V		0.1	0.6	V
	High Level Supply Current	I <sub>CCH</sub>	I <sub>F</sub> = 0 mA, V <sub>CC</sub> = 15 V		0.9	1.6	mA
	Low Level Supply Current	I <sub>CCL</sub>	I <sub>F</sub> = 10 mA, V <sub>CC</sub> = 15 V		0.9	1.6	mA
Coupled	Threshold Input Current (H → L)	I <sub>FHL</sub>	V <sub>CC</sub> = 15 V, V <sub>O</sub> = 0.6 V, I <sub>O</sub> = 2 mA			3.5	mA
	Isolation Resistance	R <sub>I-O</sub>	V <sub>I-O</sub> = 500 V <sub>DC</sub> , RH = 40 ~ 60 %	10 <sup>10</sup>			Ω
	Isolation Capacitance	C <sub>I-O</sub>	V = 0 V, f = 1 MHz		0.5	1.0	pF
	Propagation Delay Time (H → L) *2	t <sub>PHL</sub>	I <sub>F</sub> = 10 mA, V <sub>CC</sub> = 15 V, V <sub>THHL</sub> = 1.5 V, V <sub>THLH</sub> = 2.0 V, R <sub>L</sub> = 20 kΩ, C <sub>L</sub> = 100 pF	100	330	700	ns
	Propagation Delay Time (L → H) *2	t <sub>PLH</sub>		400	550	700	
	Pulse Width Distortion *2	PWD =  t <sub>PHL</sub> - t <sub>PLH</sub>			220	500	
	Common Mode Transient Immunity at High Level Output *3	CM <sub>H</sub>	T <sub>A</sub> = 25 °C, I <sub>F</sub> = 0 mA, V <sub>CM</sub> = 1.5 kV, V <sub>CC</sub> = 15 V, R <sub>L</sub> = 20 kΩ, V <sub>O</sub> > 3.0 V, C <sub>L</sub> = 100 pF	15			kV/μs
Common Mode Transient Immunity at Low Level Output *3	CM <sub>L</sub>	T <sub>A</sub> = 25 °C, I <sub>F</sub> = 10 mA, V <sub>CM</sub> = 1.5 kV, V <sub>CC</sub> = 15 V, R <sub>L</sub> = 20 kΩ, V <sub>O</sub> < 1.0 V, C <sub>L</sub> = 100 pF	15				

Notes: \*1. Typical values at T<sub>A</sub> = 25 °C

\*2. Test circuit for propagation delay time

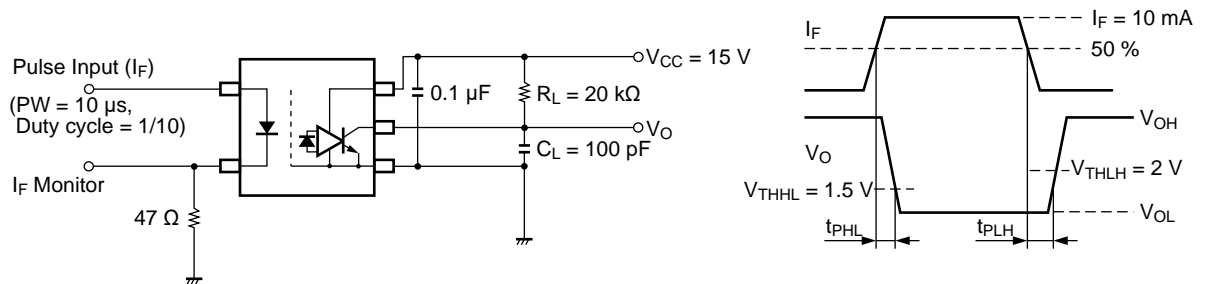

Remark C<sub>L</sub> includes probe and stray wiring capacitance.

\*3. Test circuit for common mode transient immunity

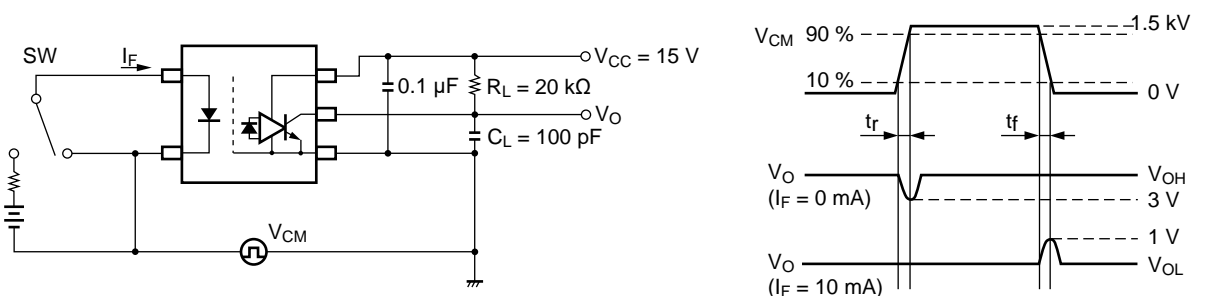

Remark C<sub>L</sub> includes probe and stray wiring capacitance.

TYPICAL CHARACTERISTICS (T<sub>A</sub> = 25 °C, unless otherwise specified)

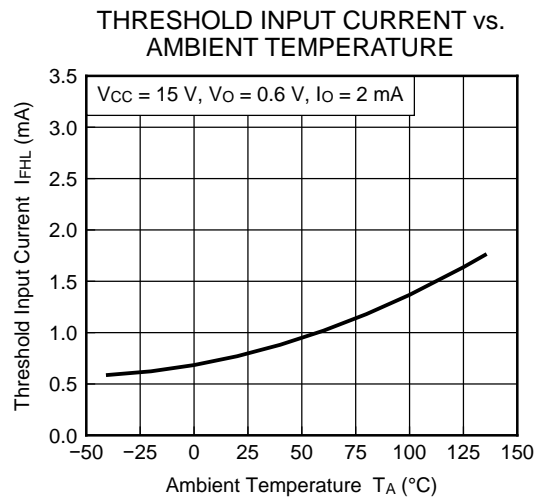
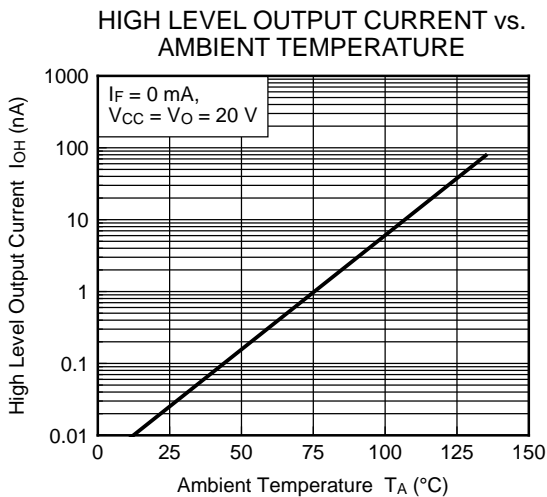
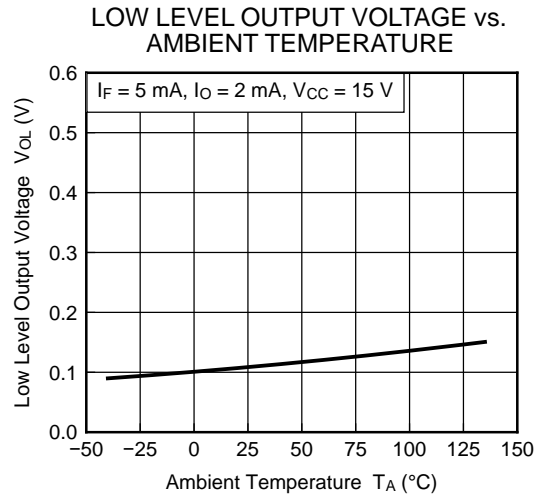
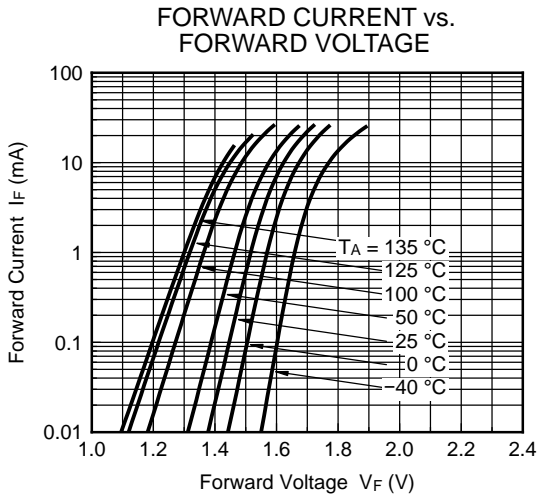
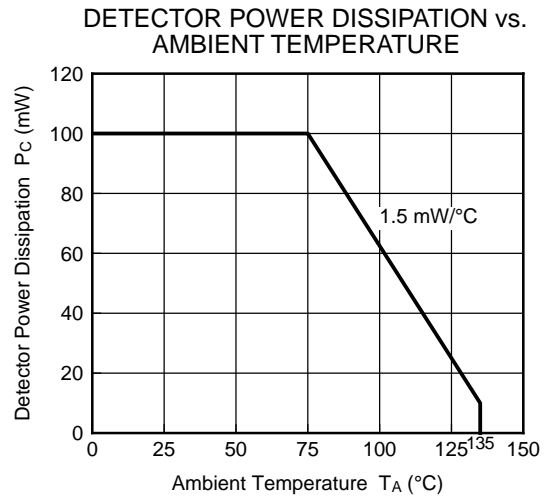
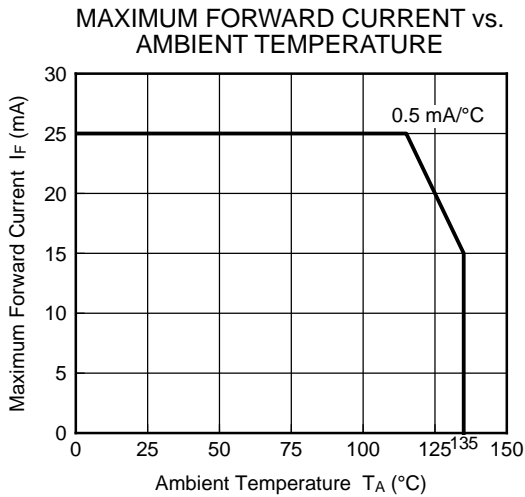

**Remark** The graphs indicate nominal characteristics.

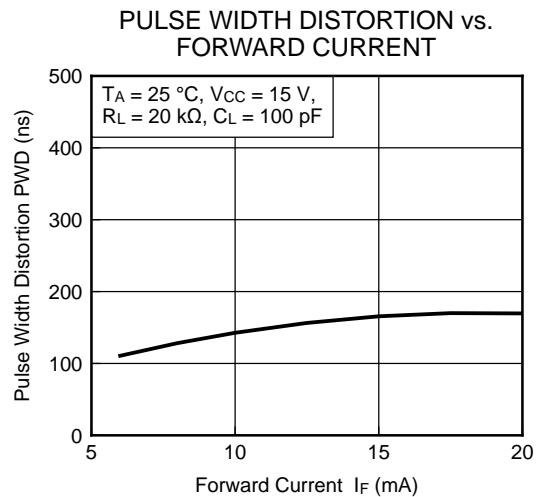
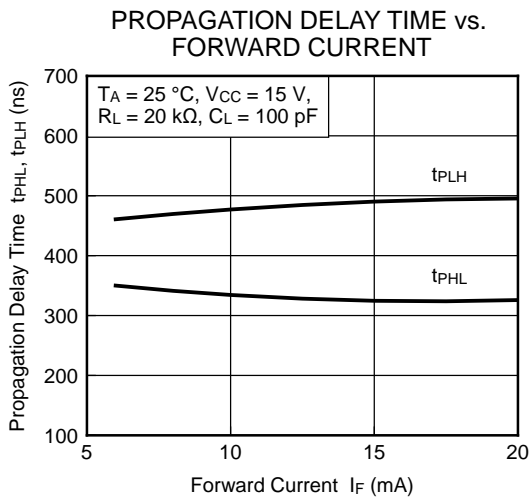
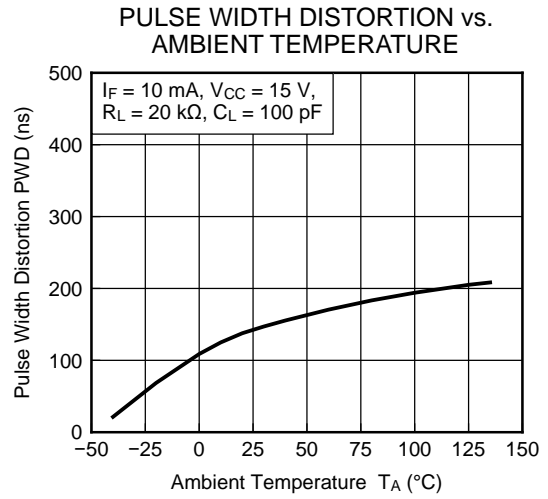
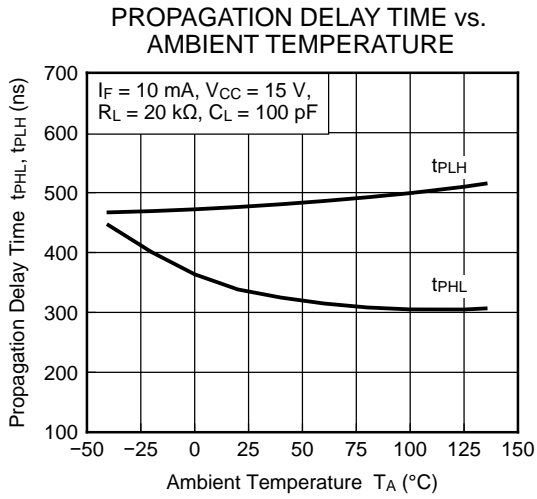
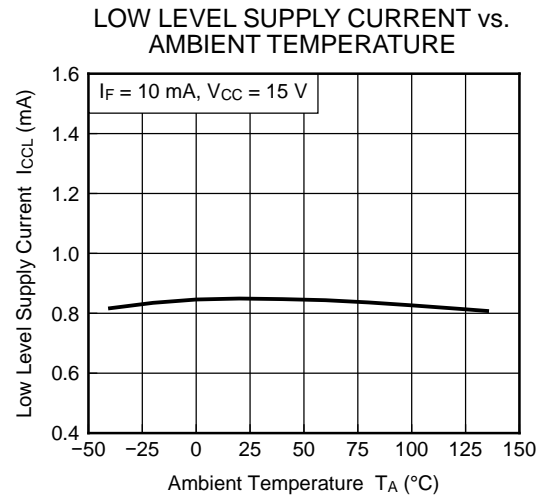
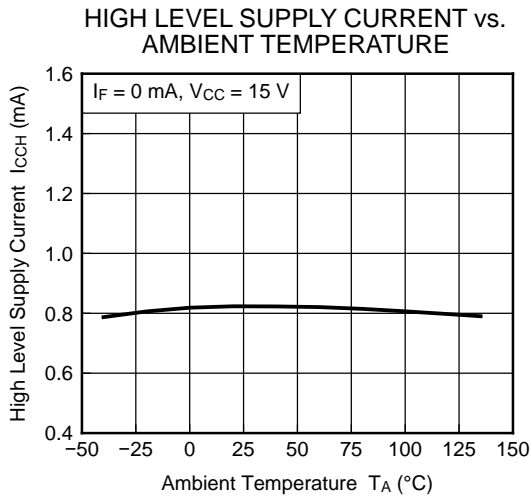

**Remark** The graphs indicate nominal characteristics.

TAPING SPECIFICATIONS (UNIT: mm)

Tape Direction

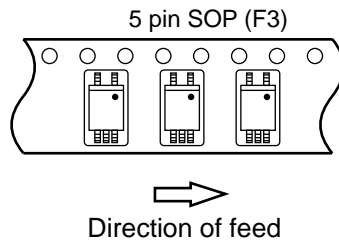

Outline and Dimensions (Tape)

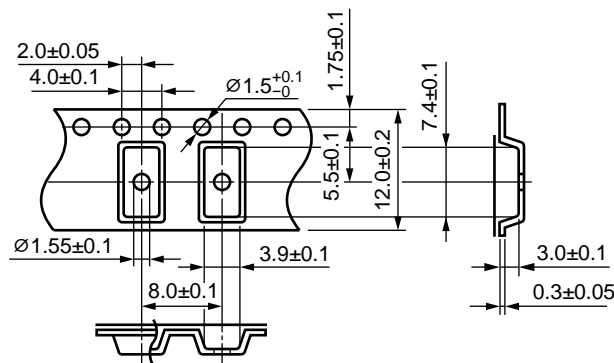

Outline and Dimensions (Reel)

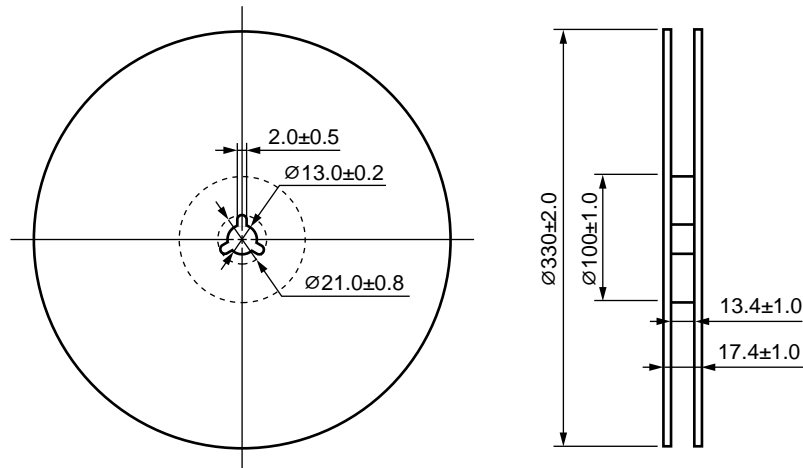

Packing: 2 500 pcs/reel

RECOMMENDED MOUNT PAD DIMENSIONS (UNIT: mm)

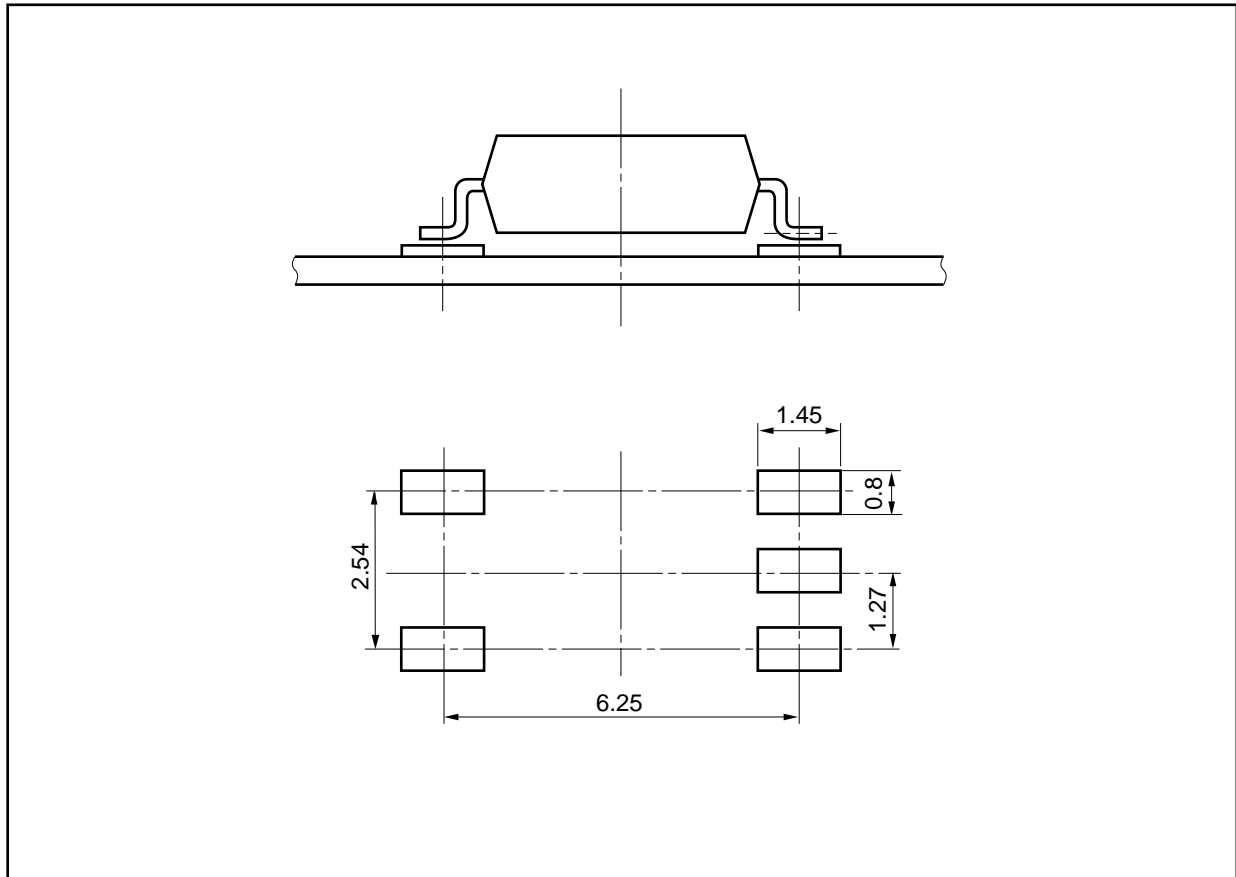

Remark All dimensions in this figure must be evaluated before use.



NOTES ON HANDLING

1. Recommended soldering conditions

(1) Infrared reflow soldering

- Peak reflow temperature 260 °C or below (package surface temperature)
- Time of peak reflow temperature -5 °C (255 °C) 30 s or less
- Time of temperature higher than 217 °C 60 ~ 150 s
- Time to preheat temperature from 150 to 200 °C 60 ~ 120 s
- Number of reflows 3
- Flux Rosin flux containing small amount of chlorine (The flux with a maximum chlorine content of 0.2 Wt% is recommended.)

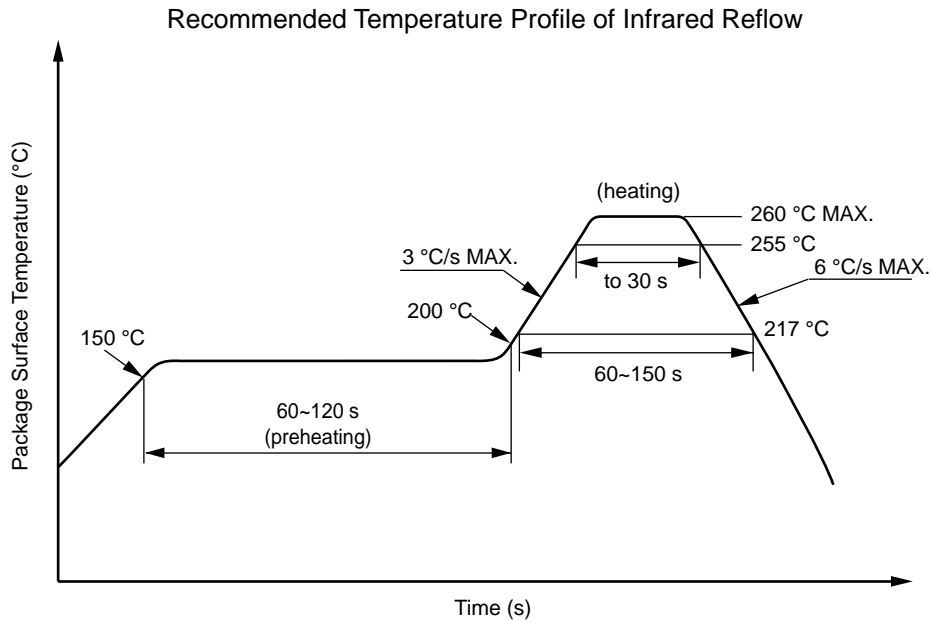

(2) Wave soldering

- Temperature 260 °C or below (molten solder temperature)
- Time 10 s or less
- Preheating conditions 120 °C or below (package surface temperature)
- Number of times One (Allowed to be dipped in solder including plastic mold portion.)
- Flux Rosin flux containing small amount of chlorine (The flux with a maximum chlorine content of 0.2 Wt % is recommended.)

(3) Soldering by Soldering Iron

- Peak temperature (lead part temperature) 350 °C or below
- Time (per one side) 3 s or less
- Flux Rosin flux containing small amount of chlorine (The flux with a maximum chlorine content of 0.2 Wt % is recommended.)
- Place 1.5 to 2.0 mm or more away from the root of the lead

(4) Cautions

- Flux cleaning Avoid cleaning with Freon- or halogen-based (chlorinated etc.) solvents.
- Fixing/Coating Do not use fixing agents or coatings containing halogen-based substances.

## USAGE CAUTIONS

1. Be aware that when voltage is applied suddenly between the photocoupler's input and output or between  $V_{CC}$  and GND at startup, the output transistor may turn on, even if the voltage is within the absolute maximum ratings.
2. By-pass capacitor of more than 0.1  $\mu\text{F}$  is used between  $V_{CC}$  and GND near the device. Also, ensure that the distance between the leads of the photocoupler and capacitor is no more than 10 mm.
3. This product is weak for static electricity due to the design of high-speed integrated circuit so protect against static electricity when handling.
4. Avoid storage at a high temperature and high humidity.

<b>Caution</b>	GaAs Products	<p>This product uses gallium arsenide (GaAs). GaAs vapor and powder are hazardous to human health if inhaled or ingested, so please observe the following points.</p> <ul style="list-style-type: none"><li>• Follow related laws and ordinances when disposing of the product. If there are no applicable laws and/or ordinances, dispose of the product as recommended below.<ol style="list-style-type: none"><li>1. Commission a disposal company able to (with a license to) collect, transport and dispose of materials that contain arsenic and other such industrial waste materials.</li><li>2. Exclude the product from general industrial waste and household garbage, and ensure that the product is controlled (as industrial waste subject to special control) up until final disposal.</li></ol></li><li>• Do not burn, destroy, cut, crush, or chemically dissolve the product.</li><li>• Do not lick the product or in any way allow it to enter the mouth.</li></ul>
----------------	---------------	--

All trademarks and registered trademarks are the property of their respective owners.